



simplefilter



POWDER SYSTEMS LIMITED

THE **simplefilter** FROM PSL

The PSL simplefilter

is a single plate pressure/ vacuum filter with simple, effective, contained off-loading via a nitrogen purged GloveBag. In order to provide maximum flexibility and adaptability, PSL's simplefilter is mobile as standard, thus allowing you to move it freely around to different areas. The simplefilter has a jacketed base for efficient drying and uncomplicated removal of the product. Simply, it is a truly versatile and cost-effective filtration solution.

Example applications:

- Hydrogenation
- Carbon filtration
- Catalyst recovery
- Pre-filter for micro-filtration
- API filtration

SIMPLE OPERATION
SIMPLE MAINTENANCE
SIMPLE SCALE-UP
SIMPLE CLEANING
SIMPLE CONTAINMENT
SIMPLE DISCHARGE
SIMPLE INSTALLATION
SIMPLE MANOEUVRABILITY



www.powdersystems.com

Powder Systems Limited is an international manufacturer of filtration, drying and high containment solutions. We have been supporting pharmaceutical, biopharmaceutical, chemical and laboratory industries since 1989.

Our experienced engineering teams work closely with our in-house chemists to accelerate process development and create the most suitable and ergonomic solutions.

Our **simplefilter™** range are fully mobile allowing you to move it freely around to different areas for maximum flexibility and adaptability.

OUR GLOBAL OFFICE BASE

PSL's established supply chain management ensures all components, sourced from across the globe, are of the highest quality and value. This enables market savings to be passed directly onto our customers.

We continue to increase our number of global offices, agents and distributors to aid the smooth distribution of equipment to any part of the world.





Stainless Steel 0.3m² simplefilter

JACKET HEATING

- The short baffled heating jacket, has flange connections provided for both inlet and return of heating/cooling fluid.

FILTRATION MEDIA

- Easily replaceable filtration media, therefore no need for filter bags/cartridges.
- 20µm nominal pore size polypropylene cloth is clamped with the use of o-rings, to secure it to the base of the vessel. Alternative filtration materials and pore sizes are available.

MANUAL BASE RAISE/LOWER

- Manual base raise/lower design allows controlled single operator use on the 0.3m² simplefilter.
- Single point, ergonomic manual base raise/lower design allows controlled single operator use on the 0.125m² simplefilter.

BASE HEATING

- The base also has a heating jacket with flange connections provided for inlet and return of heating/cooling fluid.

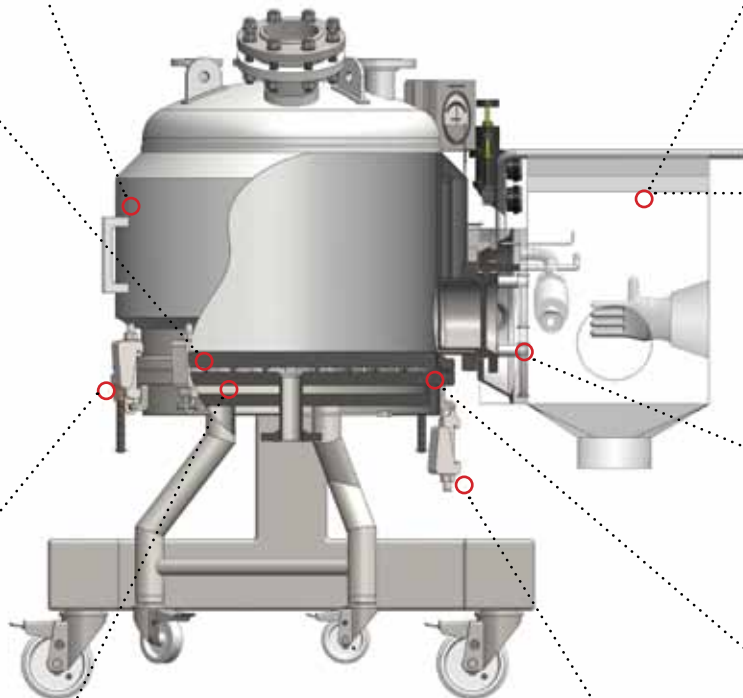

NITROGEN PURGE/EXTRACT

- PSL's GloveBag can be nitrogen purged and extracted providing hazard protection and containment.

PSL GLOVEBAG

- A flexible polyethylene isolator providing ergonomic contained discharge. Use of a heel removal tool maximises product yield from the vessel.

DISCHARGE HATCH/PLUG

- The plug is manually operated and secured by four individual 'Tommy Bar' locking handles for ease of use.

BASE

- Removable mobile base for easy cleaning on the 0.3m² simplefilter.
- The base of the vessel can swing-out, rotating around a single pivot arm on the 0.125m² simplefilter.

C-CLAMP

- C-Clamps for vessel sealing.

standard simplefilter specifications

	0.125m ²	0.3m ²
Filtration Area	0.125m ²	0.3m ²
Volume	50 Litres	130 Litres
Design Temperature Vessel & Jacket (Min)	-25°C (-13°F)	-25°C (-13°F)
Design Temperature Vessel & Jacket (Max)	150°C (300°F)	150°C (300°F)
Design Pressure Vessel (Min)	FV	FV
Design Pressure Vessel (Max)	4 barg (60 psig)	4 barg (60 psig)
Design Pressure Jacket (Min)	FV	FV
Design Pressure Jacket (Max)	6 barg (90 psig)	6 barg (90 psig)
Product Dimensions (mm)	1495 (H) x 1220 (W) x 1455 (D)	1510 (H) x 1170 (W) x 1490 (D)
Product Contact Materials	PFA Coated Carbon Steel/ 316L Stainless Steel/Alloy 22, Polypropylene, PTFE, FEP Encapsulated Silicone, Perfluoroelastomer	PFA Coated Carbon Steel/ 316L Stainless Steel/Alloy 22, Polypropylene, PTFE, FEP Encapsulated Silicone, Perfluoroelastomer
Filtration Media	Polypropylene Cloth 20µm Nominal Pore Size	Polypropylene Cloth 20µm Nominal Pore Size

simplefilter options

- Agitation Capability with High Level of Safety
- Continuous liner discharge chute provides fully contained discharge
- Internal cleaning spray balls
- Discharge plug sample port

vessel construction materials

- PFA coated carbon steel
- 316L stainless steel
- Alloy 22

filtration materials

- Different filtration media materials and pore sizes available



0.125m² PFA coated



AFTERCARE SERVICE FROM PSL

PSL Serve is our dedicated after sales customer care, on-site service and spares team. They are technical specialists, here to aid the smooth installation of new equipment, along with the servicing and repairs of existing PSL equipment and any spare parts required.

PSL Serve offers full installation, commissioning, training and preventative maintenance contracts. Information on our simplefilter IQ/OQ packages is available upon request.



POWDER SYSTEMS LIMITED

info@powdersystems.com
www.powdersystems.com