

Process Analytics

Measuring Solutions



HAMILTON 

OUR Mission

PIONEER

COLLABORATION

At Hamilton Process Analytics we pioneer open sensing solutions to enhance the understanding and control of critical process parameters. Customer collaboration drives our vision for excellence in measurement technology that works seamlessly with the infrastructure of today and the possibilities of tomorrow.

EXCELLENCE

Process Analytics Measuring Solutions

Table of Contents

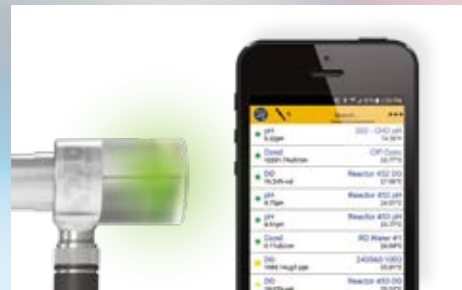

ArcAir App

See more on page 4



Single Use Sensors

See more on page 5



Cell Density

See more on page 65



Housings

See more on page 109

Highlights	4
Innovations	8
Arc Family	12
System Installations	14
Sensors	17
pH	17
ORP	39
Conductivity	53
Cell Density	65
DO	73
Beverly	88
DuraCal pH Buffers	90
Conductivity Standards	92
Oxygen Accessories	94
Electrolytes and Solutions	95
Cables	96
Arc Accessories	100
Hamilton Customized Products	101
Transmitter	102
H100	102
H220X	106
Housings	109
Sensor Comparison	144
Safety First	146
Alphabetical Index	148

Highlights

EXCELLENCE IS Intuitive Sensor Management

The New ArcAir App: One Tool for Sensor Management and Documentation



Wireless configuration and calibration

Common interface for mobile, tablet, and PC

Automated validation and documentation

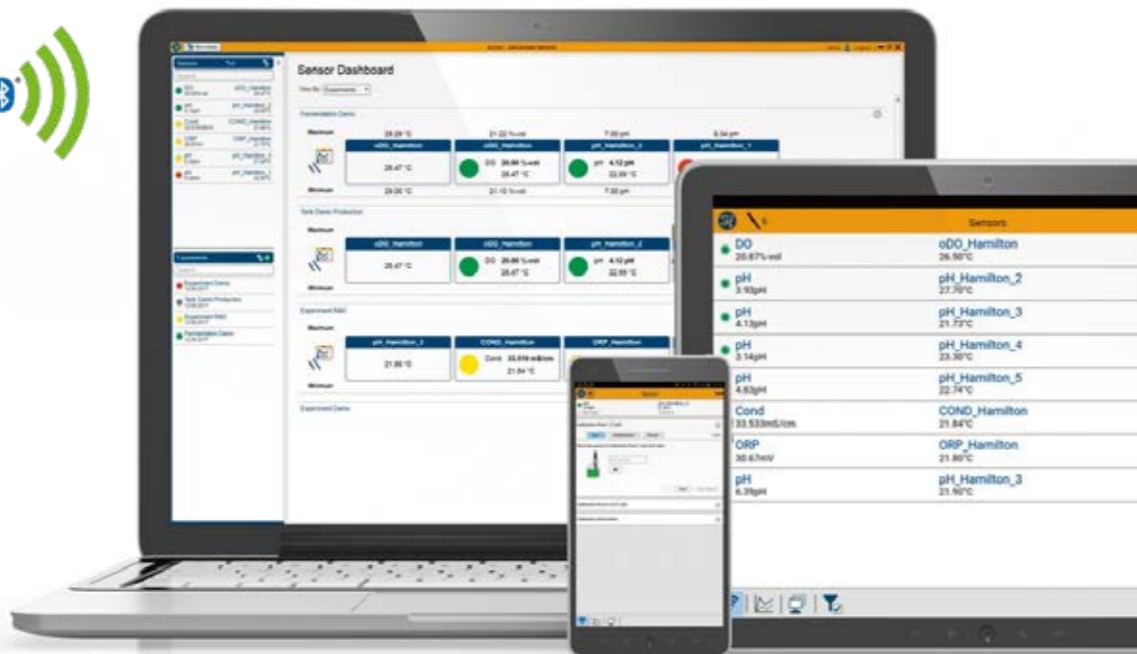

ArcAir LITE

- > Read only
- > Sensor information
- > Sensor Status and Diagnostics

ArcAir BASIC

LITE +

- > Sensor calibration
- > Sensor configuration

ArcAir ADVANCED

BASIC +

- > GMP reporting
- > User management

ArcAir App **DOWNLOAD**



SINGLE USE OneFerm pH Family

High performance electrochemical pH measurement also for single use application

The Hamilton OneFerm pH sensor is a single use glass electrode for pH measurement. It retains the high accuracy performance of a glass electrode after gamma irradiation and dry storage. It is delivered as an integrated part of a single use container to provide ease of use. The OneFerm pH sensor is available to integrators such as bag-, bioreactor- or downstream skid manufacturers.

For the OneFerm pH sensors, there is also the full range of auxiliary products available. Those products ease the integration into the system. One the one hand for the mechanical integration in the single use containers like a bag with the bag port. On the other hand also the electrical integration into the control system is covered. The OneFerm

products can connect to any type of transmitter or controller. It is also possible to integrate with the Arc Module SU pH with a digital signal. This connection is most reliable especially for the needed flexibility in single use applications.

With the OneFerm product range, special demands to the product can be covered. Resistance of the whole product including the electrolyte against high energy radiation is given. Even after this sterilization, the material are proven non-cytotoxic in the application. As the pH probe is built in into the container, the probe must withstand long dry storage time up to 18 Month without loss of accuracy or long wet-in time. Covering all those demands including the low drift in application, the OneFerm is the perfect match for application with high demands.

VisiFerm DO SU Family

Known reliability for optical dissolved oxygen measurement also for single use application

The Hamilton VisiFerm DO SU sensor systems are now also available for single use applications. It is available in a wide application range for bag and rigid containers. The Arc system makes it easily integrate able in existing or new system with the full range of connectivity to the controller. Various mechanical connections in the vessel are available with a single use sensor element and reusable electronic for a cost effective application. The new single use optical dissolved oxygen sensor

offers a reliable and comparable measurement to existing re-useable probes. With the Arc communication, the system has all possible options as know from the Hamilton re-useable sensors. It can be combined within the ArcAir™ App with all other sensors available with the Arc system. With the wireless connection and a mobile device, the calibration data shown on the label of the probe can easily written into the electronic. With this feature, the probes are ready to use within seconds.



Cell Density

Viable and Total Cell Density Monitoring

Biological processes are increasingly important in biotechnical and pharmaceutical industries. The variability of living organisms is often very high, making the culture process difficult to standardize. Extensive process optimization and control are required for stable cell cultures, fermentations and improved yield. Today bioprocess development relies on labor intensive sampling and offline measurements that also lack the necessary granularity to fully optimize the yield. The available online measurements of pH and dissolved oxygen are linked indirectly to the cell status and characteristics.

Online monitoring of cell density provides the continuous information necessary to optimize control and yield beyond what is possible offline. Hamilton now offers sensors for continuous cell density measurement. The Incyte permittivity sensor delivers information on viable cell density whereas the Dencytee sensor measures total cell density via turbidity. In combination with our advanced Arc pH and dissolved oxygen probes, permittivity and turbidity sensors provide all relevant information on the progress of mammalian, yeast and high density bacteria cultures. This enables better understanding and control of bioprocesses.



VisiFerm DO and VisiPro DO Family

Family structure now also for VisiPro DO available

With the VisiFerm DO and VisiPro DO families all sensors can be configured with H0 and H2 caps. The benefit for VisiPro DO is that the ODO cap does no longer have to be ordered separately. Additionally non-Ex versions of the VisiPro DO are available. This allows customers to configure the best suitable optical dissolved oxygen sensor, and cap in a more convenient way.



Conducell 4UxF

New product family

The variety of electrodes available has been expanded when the Conducell 4UxF family was created. In order to resist corrosive media even better Platinum electrodes were integrated into the family. The family structure helps to configure the desired sensor. All family members are available as analog sensors with VP 6 electrical connector or as Arc sensors (VP 8).



Conducell I

Inductive sensor technology to complete conductivity portfolio

Toroidal or inductive conductivity measurement technology is widely used in applications where aggressive acids might corrode metal electrodes made of stainless steel or even titanium. There are no metal parts in contact with the media, even the temperature sensor is covered by PEEK. Sensors of this type show no polarization effects and are resistant to coating and fouling. Due to their design these sensors need more space than conductive ones and are not suitable for very low conductivities. On the other side their measuring range is designed for medium to very high conductivities. So inductive sensors can be found in CIP applications as well as in filling lines in breweries. Conducell I can be connected to H100 Cond I or H220X Cond I transmitters.

Transmitter H220X

Transmitter series for Memosens and analog sensors



The H220X transmitters have an ATEX certification and use 2-wire technology. So they're designed for hazardous environments like in the chemical industry, food & beverage, and pharmaceutical industry. They're available for pH (analog & Memosens), ORP (analog & Memosens), conductivity (conductiv & inductive), and dissolved oxygen (polarographic sensor technology Memosens).



Beyond Process Analytics

Hamilton's electrochemical and optical sensors are the solution for process analytical measurement systems, characterized by proven quality and outstanding performance. Offering measurement parameter solutions in pH, ORP, dissolved oxygen and conductivity, our sensors and accessories are backed by over 50 years of engineering and manufacturing expertise in innovative design.



pH Glasses

Measurement Accuracy in Various Applications

Measurement stability and sensor lifetime in various environments requires different pH glasses.

Our high performance glasses, the PHI and the HB glass, were developed to withstand frequent steam sterilization, autoclaving and CIP cleaning using hot caustics. PHI and HB glass provide the lowest drift and show almost no shift after sterilization and cleaning procedures.

The H glass has excellent aging characteristics and offers stable readings even in samples with low water content such as anhydrous or only partially aqueous solutions. The low alkali error of H glass means accurate measurements even at high pH or high operating temperatures. HF glass ensures the longest possible lifetime in low temperature processes and processes containing hydrofluoric acid.

Foodlyte

Biocompatible Reference Electrolyte

The Foodlyte electrolyte was specifically developed for the needs of the biotechnology, pharmaceutical and food industries. It's based on food ingredients and the perfect electrolyte for applications where non-toxicity is mandatory. Foodlyte is taste-, odor- and harmless for microorganisms.

The biocompatibility is approved by MDT¹ according to EN ISO 10993-5² and USP 31, 2008 Chapter 87³ and according to international GLP⁴ guidelines.



¹ Medical Device Testing GmbH Ochsenhausen
² Biological evaluation of medical devices -- Part 5: Tests for in vitro cytotoxicity
³ Biological Activity Tests, In Vitro
⁴ Good Laboratory Practice

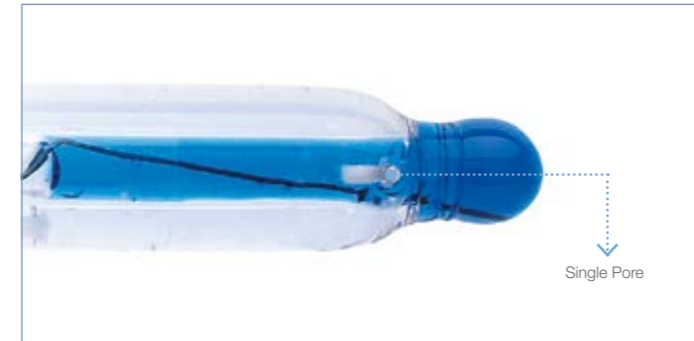

Single Pore Concept

The never-clog Liquid Junction

A Single Pore is an open liquid junction and an alternative to diaphragms. Instead of many tiny pores in a ceramic diaphragm, a single pore, about 2000 times larger in diameter, is used. This concept provides a direct contact between reference electrode and sample. In combination with the bigger diameter this liquid junction can hardly be clogged. The Single Pore results in a faster response time, more accurate readings and prevents reference poisoning.

NOTE: The PTB (Physikalisch-Technische Bundesanstalt = Physical Technical Federal Institute) in Braunschweig, Germany, determined the Single Pore pH electrode to be the most accurate laboratory electrode. Further information can be found in "Traceability of pH measurement" by Petra Spitzer; ISBN 3-89429-877-4 or ISSN 0947-7063

Polisolve Plus

Most innovative Polymer Reference Electrolyte

Hamilton has designed innovative Polisolve Plus polymer electrolyte sensors that cover the full pH range, a wide temperature range and withstand reference poisoning for an extended lifetime. It's also stable against most organic solvents and free of toxic acrylamide.

When Polisolve Plus and Single Pore concepts are combined the result is a Polilyte Plus sensor for a wide range of applications as well as a problem solver for difficult applications.

- ▶ Industrial waste water
- ▶ Hot sugar juice
- ▶ Samples containing color pigments
- ▶ Oily samples

The combination leads to more stable reference signals and minimized diffusion potentials. Polisolve Plus represents a significant contribution to long lasting pH sensors.



Conductivity Standards

Certified and Traceable

Hamilton was the first to offer conductivity standards at 1.3 and 5 $\mu\text{S}/\text{cm}$ with a certified accuracy of $\pm 1\%$ and a durability of 1.5 or 3 years. All conductivity standards exhibit a previously unknown level of stability which has been confirmed by measurements done by the PTB. Governmental metrological institutes that deal with measurement of electrolytic conductivity have become aware of these standards, and the composition of these standards is patented. The measurement procedure for determining conductivity has been developed in collaboration with the DFM¹. Each batch is certified by the DFM. In an inter-laboratory test among prestigious European metrological institutes (PTB, DFM, DAkkS²), Hamilton standards were used as a measurement solution.



¹ DFM: Danish Institute of Fundamental Metrology, Lyngby, Denmark
² DAkkS: Deutsche Akkreditierungsstelle, Wolfen, Germany



DuraCal pH Buffers

Easy Calibration with 5-Year Shelf Life

DuraCal pH buffers consist of a complete range of patented stable pH buffer solutions from pH 1.09 to pH 12.00. Hamilton guarantees that they will last for five years from the date of manufacture. The pH 9.21 and pH 10.01 buffers are even stable in air. High buffer capacities enable quick and stable calibrations.

Closed-loop traceability: In contrast with other manufacturers Hamilton has developed a “closed-loop” traceability. For users of DuraCal pH buffer solutions this means a unique level of reliability.

Top-down traceability: With Hamilton the pH value of the DuraCal buffer is determined by a comparison with two secondary reference solutions.

Bottom-up traceability: From each lot manufactured, a representative quantity is measured at DAkkS (Deutsche Akkreditierungsstelle, Wolfen, Germany). This ensures an external independent verification by an accredited institute. The DAkkS issues an official calibration certificate for every DuraCal batch manufactured.

VisiFerm DO

The most reliable Optical Dissolved Oxygen sensor in the Industry

The VisiFerm DO is the first optical dissolved oxygen (DO) process sensor for demanding applications in the pharmaceutical, biotechnology and beverage industries. The measuring principle is based on oxygen dependent quenching of the emitting light of a luminophore. Easy and fast to maintain, the multiple time-constraints caused by the use of electrochemical type DO sensors is eliminated. Decreased cost of ownership is further improved with an integrated sensor lifetime check that indicates when the sensor is in need of maintenance. A simple, replaceable cap rebuilds the sensor in seconds.

The optical measurement is independent from the flow and insensitive to CO₂. A special window behind the luminophore enables the sensor to withstand pressure hammers and spikes. Due to this design, the VisiFerm DO is suitable for inline measurement of dissolved oxygen in various processes.



Beverly

Portable Dissolved Oxygen Measurement

Beverly is designed for at-line and laboratory use in small and midsize breweries as well as in the beverage industry to provide excellent reliability in a rugged design, and purpose built to handle the environmental extremes encountered in everyday brewing operations. Superior performance at an affordable price is achieved using Hamilton's best in class optical sensor VisiFerm DO with built-in intelligence, making Beverly the brewer's best friend.

The True Power

Intelligence Integrated

Hamilton Arc revolutionizes the integration of sensors by rethinking communication between sensors, end users and process control systems (PCS). The functionality of a traditional transmitter has been replaced by a microprocessor within the sensors head. Arc sensors communicate directly with the PCS through 4-20mA standard and digital signals.

With the micro-transmitter integrated, Arc sensors offer a fully compensated, converted digital and 4-20mA signal directly to the process control system.

Fully compensated signal

- ▶ Temperature compensated
- ▶ E.g. Pressure, Salinity

Conversion to

- ▶ Digital Modbus
- ▶ 4-20mA analog
- ▶ Different parameter units (e.g. mV, ppb, %sat...)

The integrated micro-transmitter stores

- ▶ Last calibration data
- ▶ Diagnostic information
- ▶ Sensor configuration



Arc Intelligence

Wireless Communication & Calibration

Arc sensors provide full online wireless option for monitoring, configuration and calibration.

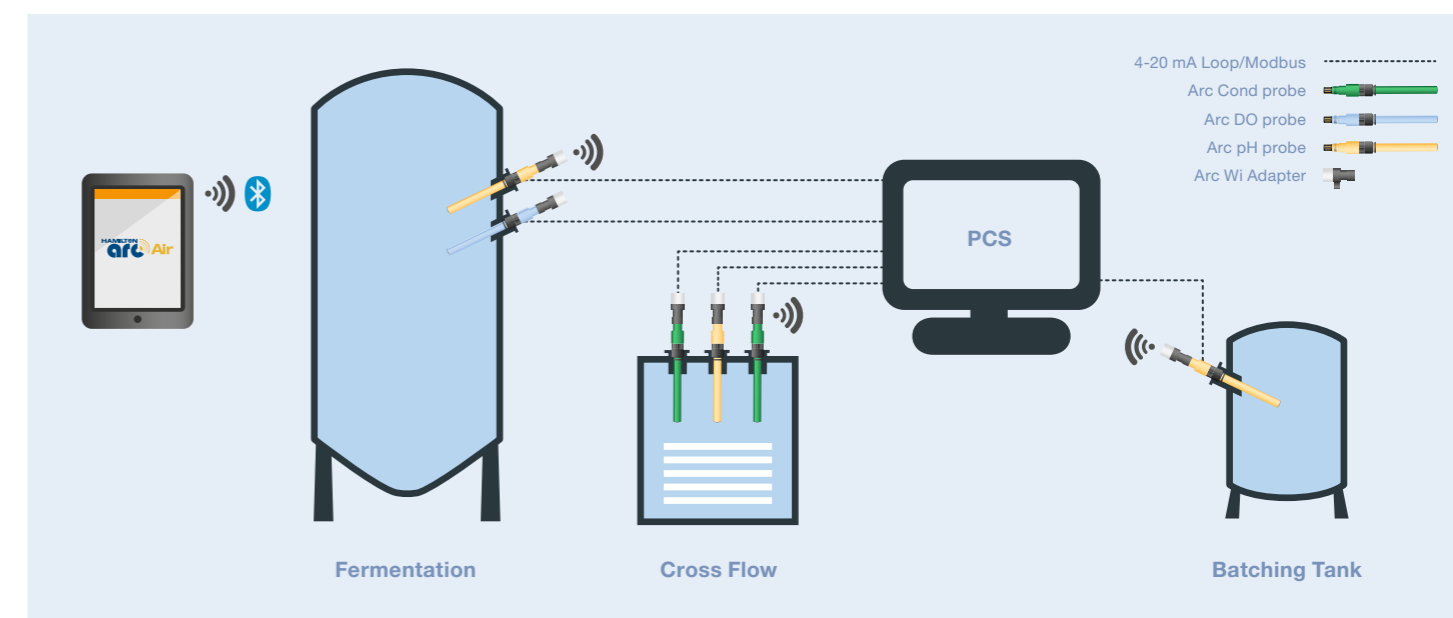

Laboratory Calibration



Complete Arc Sensor Portfolio

pH Arc



DO Arc



ORP Arc



COND Arc



Analog Systems

Standard Measuring Loop

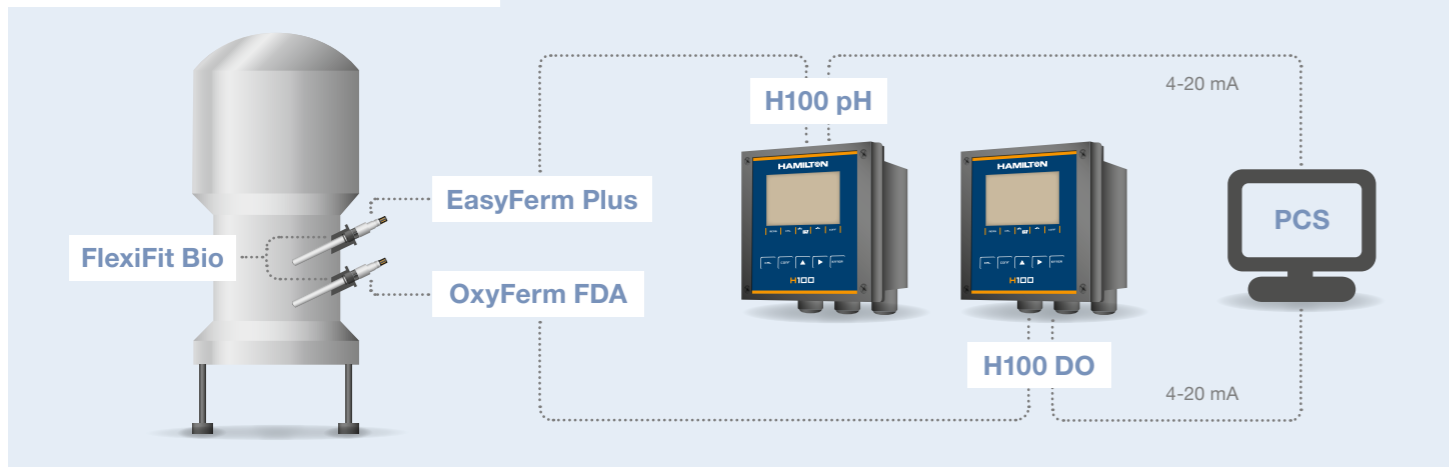

Measuring Loop in Hazardous Area

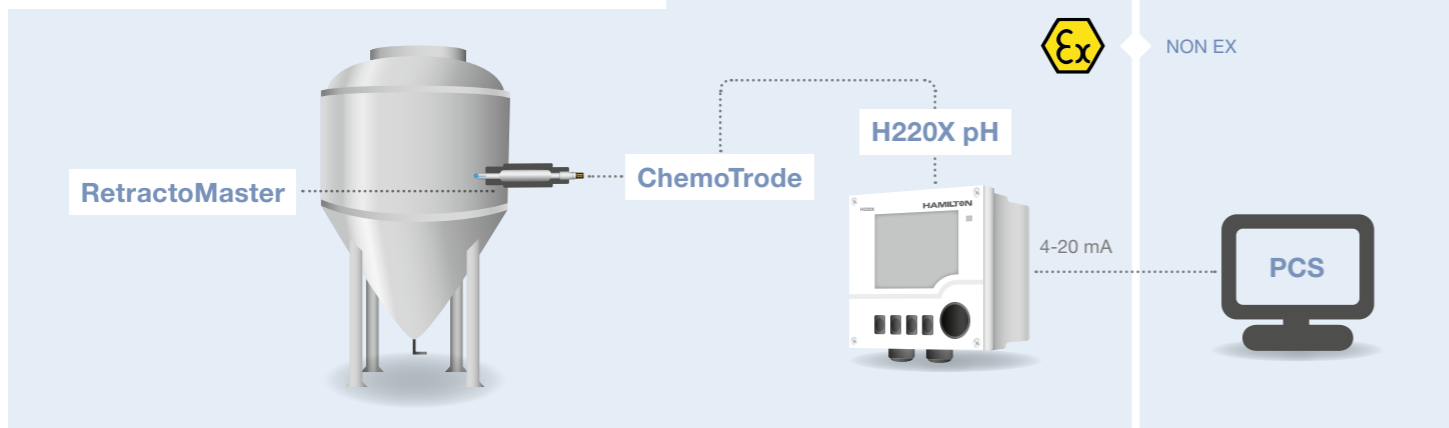

Measuring Loop in Pipe

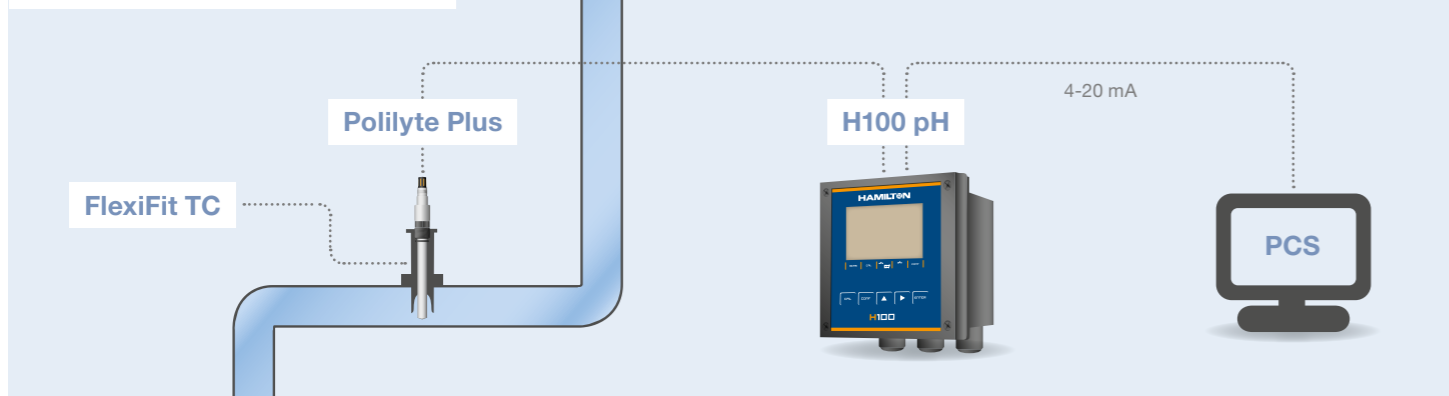

Arc Systems

Skid System

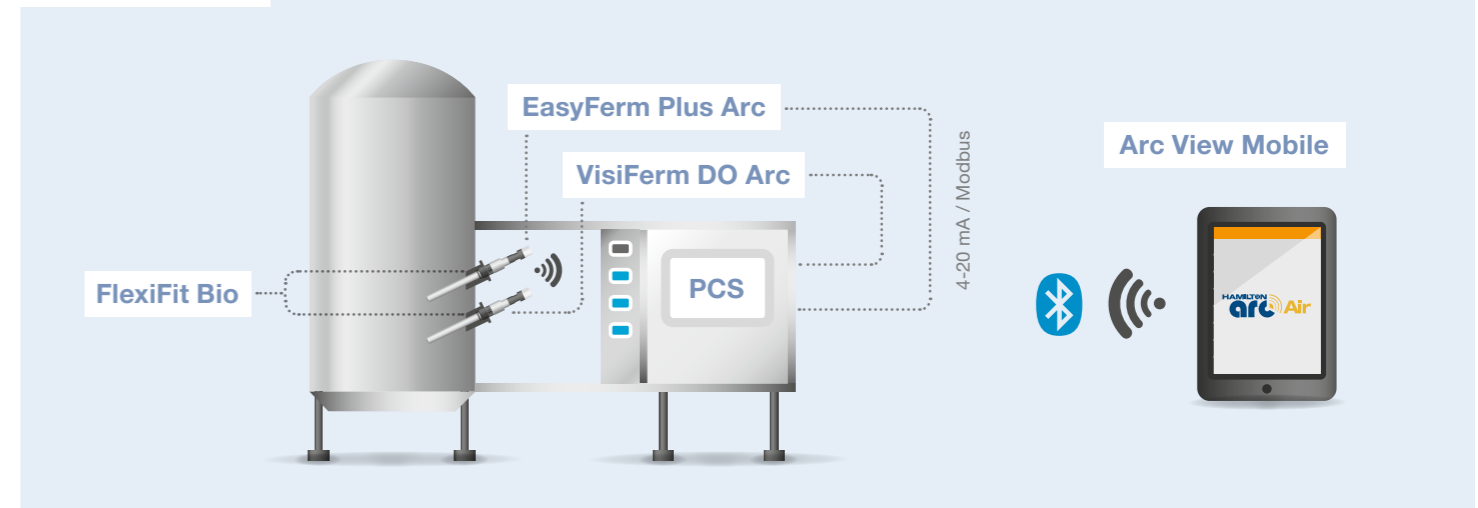

Arc in R&D

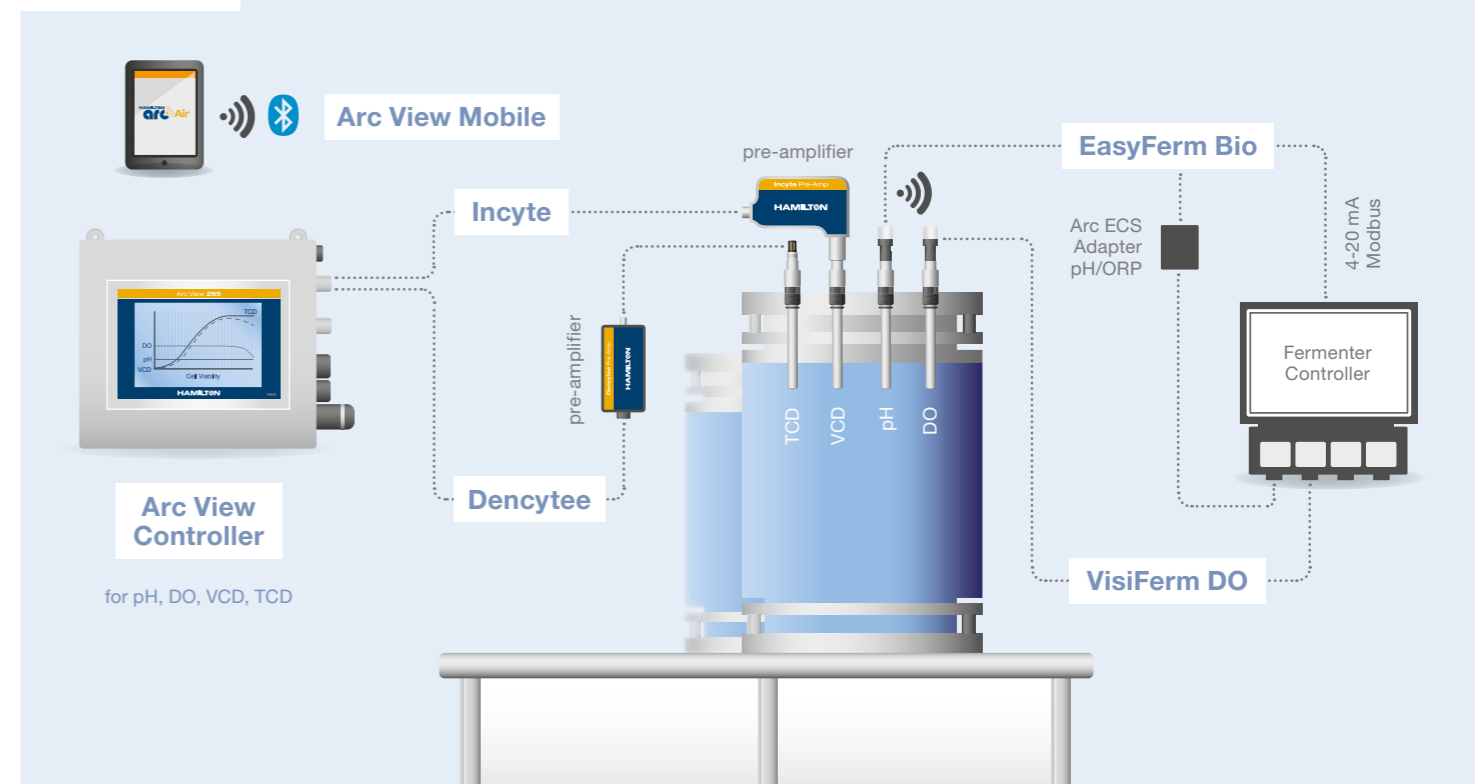

pH

pH measurements are important in many processes. There is almost none where the pH value does not play a dominant role. All biological processes depend on the activity of enzymes because they show a pH optimum and lose their functionality if the pH is too low or too high.

The pH value is measured in most processes using a glass electrode. This pH glass forms a thin gel layer in aqueous solutions that is highly selective to H⁺ ions. The pH dependent potential of the gel layer is measured against a built-in reference electrode with a constant potential. This reference electrode may be a silver wire in contact with solid silver chloride or a calomel electrode.

In general, the pH value is a measure of the acidity or the basicity of an aqueous solution. In technical terms, pH is the negative logarithm of the activity of the solvated protons H⁺. It's mostly explained as the measure of the proton concentration which is correct for dilute aqueous solutions.

Segment	Application	Sensor	Feature
Bio Pharma	Fermentation	EasyFerm Plus	Hygienic
		FermoTrode	Autoclavable CIP / SIP
Brewery / Beverage	Fermentation	EasyFerm Bio	Organic solvents
		Polilyte Plus H	Refillable
	Bottle washer	ChemoTrode	Low Conductivity
Chem Pharma		IonoTrode	
		InchTrode	
		Polyplast	Plastic Shaft
Water / Wastewater		MecoTrode	
		Easycontrol	HF
		Polilyte Plus HF	
		Liq-Glass PG	Low Temperature



Polilyte Plus family



The outstanding success of the Polilyte Plus in chemical and wastewater applications gave the inspiration for transferring the good features to a whole family of sensors. The expanded portfolio widens the range of applications that can be covered.

All members have the same reference electrolyte Polisolve Plus, use the Single Pore technology but will have different pH glasses. A new member with the HB glass will be established.

Benefits

- ▶ More applications with HB pH glass
- ▶ Better overview of the portfolio
- ▶ There's always at least one family member that suits the different applications
- ▶ Resistant against solvents, strong acids and bases

Typical applications

- ▶ Sugar industry
- ▶ Microelectronics
- ▶ Industrial waste water
- ▶ Downstream processes
- ▶ Fermentation



How to choose the sensor	New sensor	pH glass	Electrolyte	Predecessor
HF in the media, low temperature	Polilyte Plus HF	HF	Polisolve Plus	ClaryTrode
Low conductivity	Polilyte Plus H	H	Polisolve Plus	Polilyte HT
CIP, SIP, autoclavations, chemical robustness	Polilyte Plus PHI	PHI	Polisolve Plus	Polyclave
CIP, SIP, autoclavations, fast response time	Polilyte Plus HB	HB	Polisolve Plus	
High pressure	Polilyte Plus XP	H	Polisolve Plus	Polilyte Plus XP

Specifications

Measuring range	0 – 14 pH
Process temperature	See table on page 138/139
Pressure range (relative to ambient)	See table on page 138/139
Hygienic aspects	Autoclavable: H, HB, PHI CIP: HB, PHI SIP: H, HB, PHI
pH glass	See table on page 18
Electrolyte	Polisolve Plus
Reference system	Everef-L
Diaphragm	Single Pore
O-ring	EPDM*: HB, PHI FKM: H, HF

Ordering Information

Polilyte Plus Family Structure

242428	Basic number = Polilyte Plus VP 120 (old Ref)			
	Code	pH glass		
	1	H		
	2	HB (not for MS)		
	3	HF		
	4	PHI		
	Code	Electrical Connector		
	1	VP Ⓢ		
	2	S8 Ⓢ		
	3	Arc		
	4	Memosens Ⓢ		
	Code	a-length (mm)		
	1	120		
	2	225		
	3	325		
	4	360 (not for Arc, MS only with H glass)		
	5	425		
	Code	Temperature sensor		
	1	Pt100 (VP)		
	2	Pt1000 (VP)		
	3	none (S8) or given (Memosens, Arc)		
242428 –				← Order Code
238811		Polilyte Plus XP S8 120		
242415		Polilyte Plus XP VP 120		



Accessories

pH buffers see page 91

Cables see page 96

Housings see page 109

EasyFerm Plus family



Specifications	
Measuring range	0 – 14 pH
Process temperature	0 – 140 °C (Arc: analog 0 – 110 °C, digital 0 – 140 °C)
Pressure range (relative to ambient)	0 – 6 bar
Hygienic aspects	Autoclavable, SIP, CIP
pH glass	HB, PHI
Electrolyte	Phermlyte
Reference system	Everef-F
Diaphragm	HP Coatramic
O-ring	EPDM*

The EasyFerm Plus family of pH sensors is designed to withstand demanding applications in the Pharmaceutical and Chemical industries. All family members have the same reference electrolyte Phermlyte, the same type of diaphragm HP Coatramic but different pH glasses. The standard EasyFerm Plus, with its PHI glass, is directed at the BioPharm and Pharmaceutical industries because the glass has an excellent chemical robustness and provides best results in applications where sterilization either in an autoclave or an SIP is performed frequently. The new versions with the HB glass show a very fast recovery after CIP and SIP cycles leading to a shortened set-up time.

The LEVP (LE = Liquid Earth) versions have a stabilized sensor signal and an extended sensor diagnosis.

“Did you know... that with a pre-pressurized reference system the life time of a sensor is extended?”





- Benefits**
- ▶ Pre-pressurized reference electrolyte ensures a clog-free diaphragm
 - ▶ Almost drift-free measurement
 - ▶ Stable measurement signals after steam sterilization, autoclavation and CIP cleanings

- Typical applications**
- ▶ Bioreactors
 - ▶ Industrial processes
 - ▶ Downstream processes



How to choose the sensor	New sensor	pH glass	Electrolyte	Predecessor
CIP, SIP, autoclavations, chemical robustness	EasyFerm Plus PHI	PHI	Phermlyte	EasyFerm Plus
CIP, SIP, autoclavations, fast response time	EasyFerm Plus HB	HB	Phermlyte	

Ordering Information

EasyFerm Plus Family Structure					
238633	Code		pH glass		
	1		PHI (recommended pH glass type)		
	2		HB		
	Code		Electrical Connector		
	1		VP 		
	2		S8 		
	3		Arc		
	4		Memosens 		
	5		K8 		
	6		LEVP (only for 120 and 225 mm length) 		
	Code		a-length (mm)		
	1		120		
2		160			
3		200			
4		225			
5		325			
6		360 (not for Arc and only PHI glass)			
7		425			
Code		Temperature sensor			
1		Pt100 (VP, LEVP)			
2		Pt1000 (VP, LEVP)			
3		none (S8, K8) or given (Memosens, Arc)			
238633 - ← Order Code					

 Accessories
pH buffers see page  91 **Cables** see page  96 **Housings** see page  109



EasyFerm Bio family



Specifications	
Measuring range	0 – 14 pH
Process temperature	0 – 140 °C (Arc: analog 0 – 110 °C, digital 0 – 140 °C)
Pressure range (relative to ambient)	0 – 6 bar
Hygienic aspects	Autoclavable, SIP, CIP
pH glass	HB, PHI
Electrolyte	Foodlyte
Reference system	Everef-F
Diaphragm	HP Coatramic
O-ring	Silicone*

The EasyFerm Bio family of pH sensors is designed for applications in the Pharmaceutical, Biotechnology and Food & Beverage industries. All family members have the same reference electrolyte Foodlyte, with its certified bio-compatibility. Additionally the EasyFerm Bio sensors are certified to EHEDG criteria. The standard EasyFerm Bio, with its HB glass, is directed at the Food & Beverage industry where CIP and SIP cycles occur frequently because the glass shows a very fast recovery leading to a shortened set-up time. The new versions with the PHI glass show an excellent chemical robustness at high pH values.

The LEVP (LE = Liquid Earth) versions have a stabilized sensor signal and an extended sensor diagnosis.



“Did you know... that you may even eat the Foodlyte?”

Benefits

- ▶ Specifically designed for sterile applications in Pharma and Biotechnology (EHEDG, Biocompatibility)
- ▶ Highly reliable measurements after steam sterilization, autoclavation and CIP cleanings
- ▶ Drift free measurements
- ▶ Ceramic diaphragm is an improved barrier of the electrode

Typical applications

- ▶ Bioreactors
- ▶ Downstream processes
- ▶ Brewhouse
- ▶ Gelatine manufacturing



How to choose the sensor	New sensor	pH glass	Electrolyte	Predecessor
CIP, SIP, autoclavations, fast response time	EasyFerm Bio HB	HB	Foodlyte	EasyFerm Bio
CIP, SIP, autoclavations, chemical robustness	EasyFerm Bio PHI	PHI	Foodlyte	

Ordering Information

EasyFerm Bio Family Structure				
243632	Code	pH glass		
	1	PHI		
	2	HB (recommended pH glass type)		
		Code	Electrical Connector	
		1	VP	
		2	S8	
		3	Arc	
		4	Memosens	
		5	K8	
		6	LEVP (only for 120 and 225 mm length)	
			Code	a-length (mm)
			1	120
			2	160
			3	200
		4	225	
		5	325	
		7	425	
		Code	Temperature sensor	
		1	Pt100 (VP, LEVP)	
		2	Pt1000 (VP, LEVP)	
		3	none (S8, K8) or given (Memosens, Arc)	
243632 -			← Order Code	



Accessories

pH buffers see page 91

Cables see page 96

Housings see page 109

ChemoTrode / P ChemoTrode Bridge



Specifications	
Measuring range	0 – 14 pH
Process temperature	0 – 130 °C
Pressure range (relative to ambient)	0 – 6 bar
Hygienic aspects	SIP, CIP
pH glass	PHI
Electrolyte	ChemoTrode: Viscous 3 M KCl-LR ChemoTrode Bridge: Skylyte ChemoTrode P: Protelyt
Reference system	ChemoTrode: Everef-F ChemoTrode Bridge: Everef-B ChemoTrode P: Everef-F
Diaphragm	ChemoTrode: HP ceramic ChemoTrode Bridge: Platinum ChemoTrode P: HP ceramic
Temperature sensor	Pt1000 in VP version

The ChemoTrode is the most robust sensor to measure pH in demanding applications in pharmaceutical and chemical industries.

The ChemoTrode has a refill hole which allows refilling of the electrolyte and pressurization of the reference system. Its Everef-F reference cartridge ensures that the reference electrolyte remains free of silver and precipitation of proteins.



“Did you know... that the ChemoTrode Bridge has an extended life time due to its special reference system?”

Benefits

- ▶ Liquid electrolyte ensures fast response time and high precision
- ▶ Longer lifetime thanks to refillable electrolyte
- ▶ Everef-F reference cartridge extends electrode life in aggressive media

Typical applications

- ▶ Industrial processes
- ▶ Mining Industry
- ▶ Pulp and Paper industry
- ▶ Fermentations

Ordering Information

	a-length	S7	VP 6
ChemoTrode	120	238760	242700
	150	238762	242701
	200	238764	-
	250	238766	242703
ChemoTrode P	120	238761	243252
	150	238763	243253
	250	238767	243254
ChemoTrode Bridge (Non Ex)	120	238770	-
	150	238772	-
	250	238776	-

Accessories



pH buffers see page 91

Cables see page 96

Housings see page 109



FermoTrode

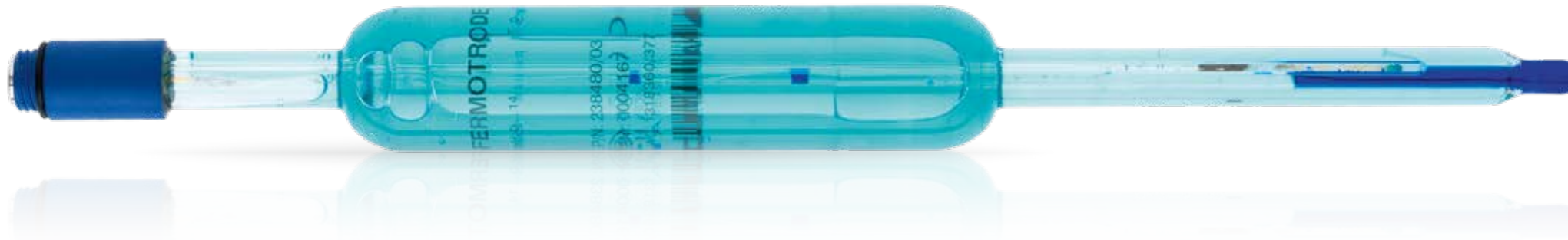

Specifications

Measuring range	0 – 14 pH
Process temperature	0 – 130 °C
Pressure range (relative to ambient)	0 – 4 bar
Hygienic aspects	SIP
pH glass	PHI
Electrolyte	Skylyte
Reference system	Everef-F
Diaphragm	Coatramic

The maintenance free FermoTrode sensors are designed for measuring pH in pharmaceutical and biotechnological industries and fit in the MasterFit and RetractoMaster housings. The Everef-F reference cartridge ensures that the reference electrolyte Skylyte remains free of silver and precipitation, and withstands steam sterilization.

It is not suited for contact with caustic soda like in CIP-cleanings or for use in media containing citric acid.

Benefits

- ▶ No air pressure required, no risk of empty reference electrolyte compartment
- ▶ 3 Coatramic diaphragms prevent clogging due to proteins
- ▶ Very long lifetime, stable calibration after sterilization and practically drift-free signals

Typical applications

- ▶ Biotechnology
- ▶ Pharmaceutical Industry



Ordering Information



	a-length	S7
FermoTrode	120	238480
	150	238482
	200	238484
	250	238486

Accessories



- pH buffers** see page 91
- Cables** see page 96
- Housings** see page 109

IonoTrode



“Did you know...

that the IonoTrode is designed for ion weak media with a low conductivity of only 0.2 μ S/cm?”

The IonoTrode sensor is designed for applications in ion weak media. The F glass membrane has a very low resistance, therefore the sensor can be used in samples with low conductivity, where it offers highest accuracy over a long period of time.

If there is a storage container with 3 M KCl attached via a tube to the side-arm of the IonoTrode, the flow-out of the electrolyte can be controlled with the sleeve diaphragm.

Benefits

- ▶ Offers highest accuracy over a long period of time
- ▶ Stable measurements in samples with low conductivity of at least 0.2 μ S/cm
- ▶ Removable PTFE sleeve diaphragm to check electrolyte outflow
- ▶ Side-arm attachment via tube to storage vessel containing 3 M KCl, and control of electrolyte flow with PTFE diaphragm ring

Typical applications

- ▶ Drinking Water Plants
- ▶ Boiler Feed Water

Specifications

Measuring range	0 – 14 pH
Process temperature	-10 – 40 °C
Pressure range (relative to ambient)	0 – 0.5 bar or higher if pressurization by side-arm
pH glass	F
Electrolyte	3 M KCl
Reference system	Everef
Diaphragm	Sleeve
O-ring	EPDM*

Ordering Information

	a-length	S7
IonoTrode	120	238525

Accessories



pH buffers see page [91](#)

Cables see page [96](#)

Housings see page [109](#)



InchTrode



Specifications	
Measuring range	0 – 14 pH
Process temperature	-10 – 130 °C (flat membrane) 0 – 130 °C (cylindrical membrane)
Pressure range (relative to ambient)	0 – 10 bar (25 °C) 0 – 6 bar (130 °C)
pH glass	HF (flat membrane) PHI (cylindrical membrane)
Electrolyte	Polisolve
Reference system	Everef-L
Diaphragm	Single Pore
Temperature sensor	Pt1000 in VP version Pt100 in fix cable version

The InchTrode sensors are designed to measure pH in demanding applications in the paper making as well as in the chemical industries. The Single Pore liquid junction guarantees the best and fast measuring results because of direct contact between the sample and the Polisolve electrolyte.

The InchTrode sensors are easy to install without additional housing and have a robust PEEK shaft.

“  Did you know... that the InchTrode is available in two different sizes and with different membrane shapes? ”

- Benefits**
- ▶ Single Pore for direct sample contact with Polisolve electrolyte – no clogging
 - ▶ Very long-lasting reference system
 - ▶ Robust PEEK shaft
 - ▶ Simple installation without additional housing

- Typical applications**
- ▶ Pulp and Paper industry
 - ▶ Water and Wastewater

Ordering Information

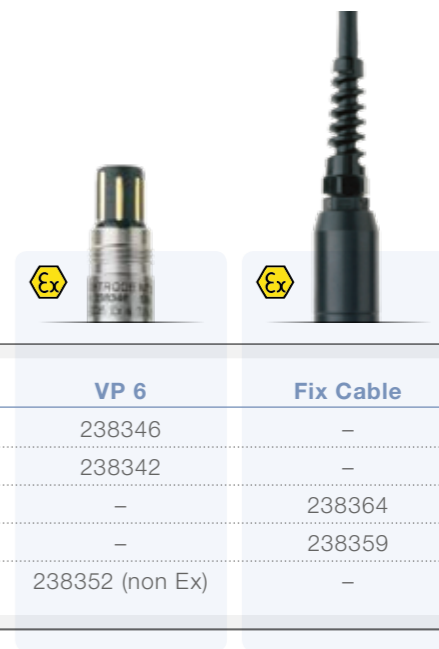

InchTrode	Type	a-length	VP 6	Fix Cable
	N75F	143	238346	–
	N75P	150	238342	–
	N75FC10	143	–	238364
	N75PC10	150	–	238359
	N100F	140	238352 (non Ex)	–

F = Flat membrane
P = Cylindrical membrane
C = Fix cable

Accessories



- pH buffers** see page 91
- Cables** see page 96
- Housings** see page 109



MecoTrode



Specifications

Measuring range	0 – 14 pH
Process temperature	0 – 130 °C
Pressure range (relative to ambient)	0 – 16 bar (25 °C) 0 – 6 bar (130 °C)
pH glass	MecoTrode: H MecoTrode HF: HF
Electrolyte	Viscous 3 M KCl-Pharma, blue
Reference system	Everef
Diaphragm	HP ceramic
Temperature sensor	Pt100 in VP version
O-ring	EPDM*

The maintenance free MecoTrode sensor is designed for processes in the chemical industry with extreme pH values. The H glass type membrane glass provides a low alkaline error and stable measurement even at high temperatures.

Three high-performance ceramic diaphragms reduce the effect of flow potential in pipe mounting.



“ Did you know...
that the MecoTrode is already
20 years in the market? ”

Benefits

- ▶ 3 high performance ceramic diaphragms for reduced flow potentials when mounted in pipes
- ▶ «H» glass for most accurate readings at high pH values or high temperatures
- ▶ Very good precision at low pH values (pH < 2)

Typical applications

- ▶ Water and Wastewater
- ▶ Industrial processes

Ordering Information

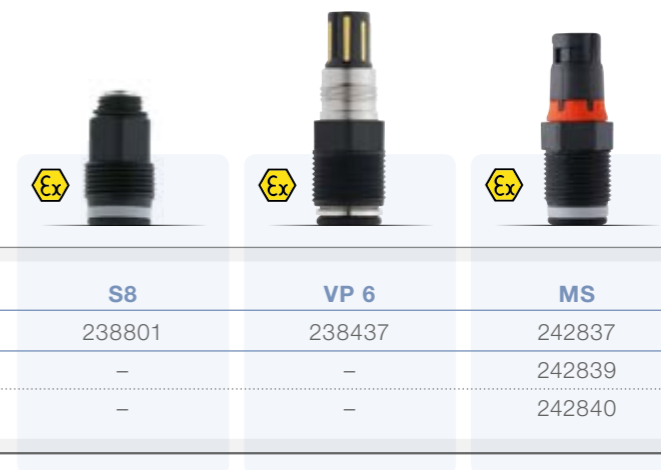

	a-length	S8	VP 6	MS
MecoTrode	120	238801	238437	242837
MecoTrode HF	120	-	-	242839
	225	-	-	242840

Accessories



- pH buffers see page 91
- Cables see page 96
- Housings see page 109



Polilyte Pro Polyplast Pro



“ Did you know...
that the Polilyte Pro has the
HF resistant pH glass? ”

The maintenance free Polilyte Pro and Polyplast Pro sensors are designed for pH measurement in water applications, especially in low conductivity samples, e.g. wastewater, fish farming, ground water, etc.

The Single Pore liquid junction guarantees best measurement results because of direct contact between the sample and the Polysolve electrolyte – clogging is nearly impossible. The Polyplast Pro sensor comes with a robust plastic shaft and glass bulb protection.

Benefits

- ▶ Single Pore for direct sample contact with Polysolve electrolyte
- ▶ No clogging
- ▶ Fast response even in low conductivity media
- ▶ Easy maintenance due to non-refillable electrolyte

Typical applications

- ▶ Wastewater applications
- ▶ Fish farming
- ▶ Ground water

Specifications

Measuring range	0 – 14 pH
Process temperature	Polilyte Pro: -10 – 60 °C Polyplast Pro: -10 – 40 °C
Pressure range (relative to ambient)	0 – 6 bar
pH glass	Polilyte Pro: HF Polyplast Pro: V
Electrolyte	Polysolve
Reference system	Polilyte Pro: Everef-B Polyplast Pro: Ag/AgCl
Diaphragm	Single Pore
Temperature sensor	Pt1000 in VP version
O-ring	Polilyte Pro: EPDM* Polyplast Pro: EPDM*

Ordering Information

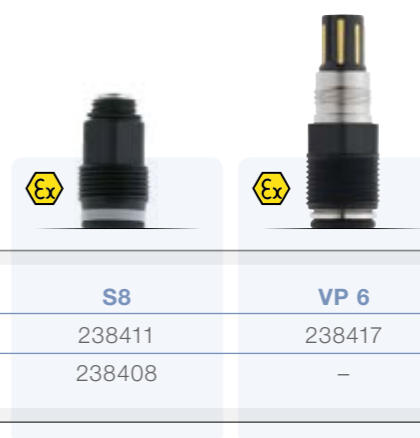

	a-length	S8	VP 6
Polilyte Pro	120	238411	238417
Polyplast Pro	120	238408	-

Accessories



pH buffers see page 91

Cables see page 96

Housings see page 109



Liq-Glass PG EasyControl



Specifications	
Measuring range	Liq-Glass PG: 1 – 12 pH EasyControl: 0 – 14 pH
Process temperature	Liq-Glass PG: -5 – 60 °C EasyControl: 0 – 60 °C
Pressure range (relative to ambient)	0 – 2 bar
pH glass	Liq-Glass PG: F EasyControl: HF
Electrolyte	Liq-Glass PG: Viscous 3 M KCl-LR EasyControl: Viscous 3 M KCl-Pharma
Reference system	Liq-Glass PG: Everref EasyControl: Ag/AgCl
Diaphragm	Ceramic
O-ring	Liq-Glass: EPDM* EasyControl: EPDM*

The maintenance free Liq-Glass PG and the EasyControl sensors are entry level sensors for chemical or waste water applications and low process temperatures. They show good behavior in samples containing few ions, respectively low conductivity.



“ Did you know...
that the EasyControl is also
available as ORP sensor? ”

Benefits

- ▶ Suitable for low conductivity media
- ▶ Easy maintenance due to non-refillable electrolyte
- ▶ Liq-Glass PG has 3 ceramic diaphragms for reduced flow potentials

Typical applications

- ▶ Wastewater applications
- ▶ Fish farming
- ▶ Ground water
- ▶ Swimming Pools

Ordering Information



	a-length	S8
Liq-Glass PG	120	238515
EasyControl (Non Ex)	120	238522

Accessories



- pH buffers** see page 91
- Cables** see page 96
- Housings** see page 109





ORP

ORP (Oxidation Reduction Potential) is a common measurement in biochemistry, environmental chemistry and water quality. In the biochemical perspective, an oxidizing chemical pulls electrons away from the cell membrane which means it can be destabilized and leaky. The rapid death of a cell is the consequence of a destroyed membrane. The ORPs of natural systems like aerated surface water, rivers, lakes, rainwater and acid mine water usually have oxidizing conditions leading to positive potentials. Submerged soils, swamps and marine sediments, where air supply has its limitations, reducing conditions are the norm leading to negative potentials. For water system monitoring, the ORP value provides the operator with a rapid and single-value assessment of the disinfection potential of water in the postharvest system. This enables the operator to assess the activity of the applied disinfectant rather than the applied dose.

ORPs in aqueous solutions are determined by measuring the potential difference between an inert sensing electrode in contact with the solution and a stable reference electrode. The reference electrode is connected to the solution by a salt bridge. It has a known potential and is made of silver chloride or saturate calomel. Platinum is frequently used for the sensing electrode.

The Oxygen-Reduction Potential, also known as Redox Potential describes the tendency of a chemical species or a solution to acquire electrons and therefore to be reduced. Each species has its own reduction potential. It is measured in Volts (V) or mV.

Polilyte Plus ORP



Specifications	
Measuring range	± 2000 mV (Arc: ± 1500 mV)
Process temperature	0 – 130 °C (Arc: analog 0 – 110 °C, digital 0 – 130 °C)
Pressure range (relative to ambient)	0 – 3 bar (140 °C) 0 – 10 bar (130 °C) 0 – 16 bar (100 °C)
Hygienic aspects	Autoclavable, CIP, SIP
ORP element	Pt wire
Electrolyte	Polisolve Plus
Reference system	Everef-L
Diaphragm	Single Pore
O-ring	FKM

The maintenance free Polilyte Plus ORP sensors are designed to withstand demanding applications in chemical and petrochemical industries. Monitoring the ORP value is becoming increasingly important in many applications, especially harsh chemical environments or high alkaline wastewater. Because of its Single Pore diaphragms you will never have liquid junction problems and total breakdowns. The Polilyte Plus ORP sensors demonstrate reliable reproducible measurement accuracy in highly alkaline solutions as well as in samples with low conductivity. Additionally, the Everef-L reference cartridge ensures a long lifetime.

- Benefits**
- ▶ 2 Single Pores prevent clogging and ensure reliable measurements
 - ▶ Minimal diffusion potential
 - ▶ Highly reproducible measurements and very stable over a long period of time
 - ▶ Resistant against solvents, strong acids and bases

- Typical applications**
- ▶ Sugar industry
 - ▶ Dye industry
 - ▶ Industrial wastewater
 - ▶ Paper industry

Ordering Information



	a-length	S8	Arc	VP 6
Polilyte Plus ORP	120	243185	243060	243648
	225	243186	243061	-
	325	-	243062	-
	425	-	243063	-

Accessories



- ORP buffers** see page 91
- Cables** see page 96
- Arc Accessories** see page 100
- Housings** see page 109



EasyFerm Plus ORP



Specifications

Measuring range	± 2000 mV (Arc: ± 1500 mV)
Process temperature	0 – 140 °C (Arc: analog 0 – 110 °C, digital 0 – 140 °C)
Pressure range (relative to ambient)	0 – 6 bar
Hygienic aspects	Autoclavable, CIP, SIP
ORP element	Pt ring
Electrolyte	Phermlyte
Reference system	Everef-F
Diaphragm	HP Coatramic
O-ring	EPDM*

The EasyFerm Plus ORP sensors are designed to withstand demanding applications in pharmaceutical and chemical industries. It is supplied with a pre-pressurized electrolyte which prevents the diffusion of sample into the sensors. The Everef-F reference cartridge ensures that the Phermlyte reference electrolyte remains free of silver and precipitation.

Measuring the ORP value is getting more and more important in the branches mentioned above.

Benefits

- ▶ Pre-pressurized reference electrolyte ensures a clog-free diaphragm
- ▶ Almost drift-free measurement
- ▶ Stable measurement signals after steam sterilization, autoclavation and CIP cleanings
- ▶ Large platinum ring

Typical applications

- ▶ Bioreactors
- ▶ Industrial processes
- ▶ Downstream processes

Ordering Information

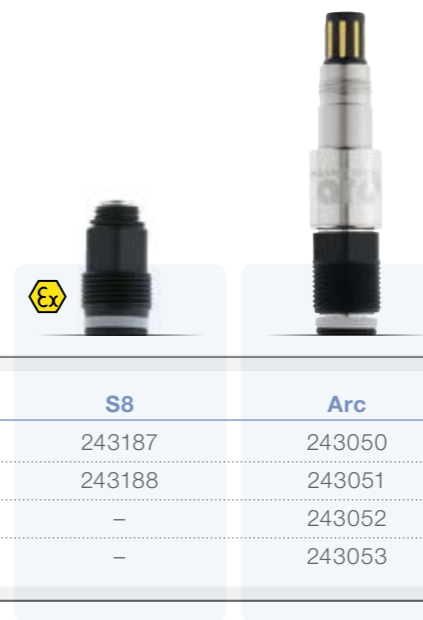

	a-length	S8	Arc
EasyFerm Plus ORP	120	243187	243050
	225	243188	243051
	325	–	243052
	425	–	243053

Accessories



ORP buffers see page 91

Cables see page 96

Arc Accessories see page 100

Housings see page 109



ChemoTrode ORP



Specifications

Measuring range	± 2000 mV
Process temperature	0 – 130 °C
Pressure range (relative to ambient)	0 – 6 bar
ORP element	Pt ring
Electrolyte	Viscous 3 M KCl-LR
Reference system	Everef-F
Diaphragm	HP Ceramic

The ChemoTrode ORP is the most robust sensor to measure the oxidation-reduction potential in demanding applications in pharmaceutical and chemical industries. The ChemoTrode has a refill hole which allows refilling the electrolyte and pressurization of the reference electrolyte. Its Everef-F reference cartridge ensures that the reference electrolyte remains free of silver and precipitation of proteins.

Benefits

- ▶ Liquid electrolyte ensures fast response time and high precision
- ▶ Longer lifetime thanks to refillable electrolyte
- ▶ Everef-F reference cartridge extends electrode life in aggressive media

Typical applications

- ▶ Industrial processes
- ▶ Mining Industry
- ▶ Pulp and Paper industry
- ▶ Fermentations

Ordering Information



	a-length	S7
ChemoTrode ORP	120	238740
	150	238742

Accessories



- ORP buffers** see page 91
- Cables** see page 96
- Housings** see page 109



OxyTrode Pt



The maintenance free OxyTrode Pt is an ORP sensor designed for processes in the chemical industry and for applications in wastewater treatment. Three high-performance ceramic diaphragms reduce the effect of flow potential in pipe mounting.



“Did you know... that the OxyTrode Pt is the ORP version of the MecoTrode?”

Benefits

- ▶ 3 high performance ceramic diaphragms for reduced flow potentials when mounted in pipes
- ▶ Platinum wire coil welded onto the glass

Typical applications

- ▶ Water and Wastewater
- ▶ Industrial processes



Specifications

Measuring range	± 2000 mV
Process temperature	0 – 130 °C
Pressure range (relative to ambient)	0 – 16 bar (25 °C) 0 – 6 bar (130 °C)
ORP element	Pt wire
Electrolyte	Viscous 3 M KCl-Pharma, blue
Reference system	Everef
Diaphragm	HP ceramic
O-ring	EPDM*

Ordering Information



	a-length	S8
OxyTrode	120	238810

Accessories



ORP buffers see page [91](#)

Cables see page [96](#)

Housings see page [109](#)

Polilyte RX Polyplast Pro RX



The maintenance free Polilyte RX and Polyplast Pro RX sensors are designed for ORP measurement in water applications and low conductivity samples, e.g. wastewater, fish farming, ground water, etc.

The Single Pore liquid junction guarantees best measurement results because of direct contact between the sample and the Polysolve electrolyte – clogging is nearly impossible. The Polyplast Pro sensor comes with a robust plastic shaft and glass bulb protection, making it one of our most economical and longest lasting sensors.

Benefits

- ▶ Single Pore for direct sample contact with Polysolve electrolyte
- ▶ No clogging
- ▶ Fast response even in low conductivity media
- ▶ Easy maintenance due to non refillable electrolyte

Typical applications

- ▶ Wastewater applications
- ▶ Fish farming
- ▶ Ground water

Specifications	
Measuring range	± 2000 mV
Process temperature	Polilyte Pro: -10 – 60 °C Polyplast Pro: -10 – 40 °C
Pressure range (relative to ambient)	0 – 6 bar
ORP element	Pt-wire
Electrolyte	Polysolve
Reference system	Polilyte Pro: Everef-B Polyplast Pro: Ag/AgCl
Diaphragm	Single Pore
O-ring	Polilyte RX: EPDM* Polyplast Pro RX: EPDM*

Ordering Information



	a-length	S8
Polilyte RX	120	238433
Polyplast Pro RX	120	238409

Accessories



- ORP buffers** see page 91
- Cables** see page 96
- Housings** see page 109



EasyControl ORP



Specifications	
Measuring range	± 2000 mV
Process temperature	0 – 60 °C
Pressure range (relative to ambient)	0 – 2 bar
ORP element	Pt-wire
Electrolyte	Viscous 3 M KCl-Pharma
Reference system	Ag/AgCl
Diaphragm	Ceramic
O-ring	EPDM*

The maintenance free EasyControl ORP is an entry level ORP sensor for chemical or wastewater applications and low process temperatures.

It is also often used in swimming pools to control the disinfection with chlorine. They show also good behavior in samples containing few ions, with respectively low conductivity.

Benefits

- ▶ Suitable for low conductivity media
- ▶ Easy maintenance due to non refillable electrolyte

Typical applications

- ▶ Wastewater applications
- ▶ Fish farming
- ▶ Ground water
- ▶ Swimming Pools

Ordering Information

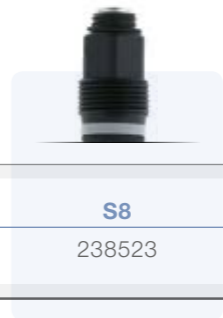

	a-length	S8
EasyControl ORP	120	238523

Accessories



- ORP buffers** see page 91
- Cables** see page 96
- Housings** see page 109



Cond

The electrical conductivity is important for the characterization of liquids in different kinds of processes. In aqueous solutions the conductivity is caused by the decomposition of dissolved acids, bases or salts into positive cations and negative anions. In ultra-pure water, where no ions, except very few H_3O^+ and OH^- , are present, the conductivity is extremely low. This intrinsic conductivity of water represents the lower border of the conductivity scale.

The electrical conductivity is determined by a resistivity measurement when an alternating voltage is applied to a measurement cell that consists of two or four electrodes. To compensate for the geometry of the conductivity cell a cell constant is used. This constant is either known or determined by means of conductivity standards.

Electrical conductivity is the reciprocal of electrical resistivity, and measures a material's ability to conduct an electric current. Its SI unit is Siemens per meter (S/m). For the measurement of the conductivity of a solution it's common to use $\mu S/cm$ or mS/cm .

Segment / Application	Sensor	Feature
CIP station	Conducell I	Inductive
Bio Pharma	Conducell 4UxF	Varivent®
Chem Pharma	Conducell 4US	4 pole / wide measuring range
Brewery / Beverage	Conducell UPW	Various O-ring positions
UPW	Conducell UPW	Triclamp
Waste Water	Conducell 2DC	2 pole

Conducell 4UxF family



Specifications

Measuring range	1 µS/cm – 300 mS/cm
Measurement Principle	4 pole contacting
Process temperature	-20 – 150 °C (Arc: analog 0 – 110 °C, digital 0 – 140 °C)
Pressure range (relative to ambient)	-1 – 20 bar (135 °C) -1 – 10 bar (140 °C)
Hygienic aspects	Autoclavable, CIP, SIP
Cell constant	0.36/cm
Material of electrodes (x)	S = Stainless steel 1.4435 H = Hastelloy C 2.4602 T = Titanium Pt = Platinum
O-ring	EPDM*

Other versions available on request

Drawing of Conducell 4USF-VV all dimensions in mm

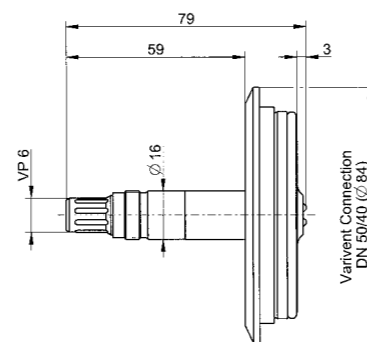

The Conducell 4UxF sensors are suited for measurements in hygienic applications. All wetted parts are FDA approved, can be cleaned easily and withstand CIP cleanings and autoclavations. The sensors show a very good linearity over a broad measuring range.

They are available with different process connections such as BioConnect® (BC) or Varivent®.

The Conducell 4USF with stainless steel electrodes is most common and suitable for many applications.

All plastic materials are compliant with the order EU 10/2011.

Benefits

- ▶ Very good linearity, especially for applications with sharp variations in conductivity
- ▶ All wetted parts are FDA-compliant
- ▶ Sensor is very easy to clean due to the forward facing, flush arrangement of electrodes
- ▶ Specifically designed for sterile applications in Pharma and Biotechnology (EHEDG)

Typical applications

- ▶ CIP station
- ▶ Water preparation

Ordering Information

Conducell 4UxF Family Structure

243590	Code		Electrode Material	
	1		Stainless Steel	
	2		Platinum	
	3		Hastelloy 2.4602	
	4		Titanium	
	Code		Electrical Connector	
	1		Arc	
	2		VP	
	Code		a-length (mm)	
	1		120	
	2		225	
	3		325	
4		425		
Code		O-ring Material		
1		EPDM		
243590 -	← Order Code			

	a-length	VP 6
Conducell 4USF-VV	3	237640
Conducell 4USF-BC	21	237650 (non Ex)

VV = Varivent®
BC = BioConnect

Accessories



Conductivity Standards see page 92

Cables see page 96

Housings see page 109



Conducell 4US



The Conducell 4US 4-pole conductivity sensors are designed for different process connections such as Triclamp or G 1¼" with various O-ring positions.

The sensors show a very good linearity over a broad range of conductivities.

The Conducell 4US 4-pole sensor can easily be cleaned and is suitable for steam sterilization, autoclavation and CIP cleanings.

All plastic materials are compliant with the order EU 10/2011.

Benefits

- ▶ Very good linearity, especially for applications with wide variations in conductivity
- ▶ All wetted parts are FDA-compliant
- ▶ Sanitary: Sensor is easy to clean
- ▶ O-ring position can be chosen individually

Typical applications

- ▶ Fermentation
- ▶ Chemical industry

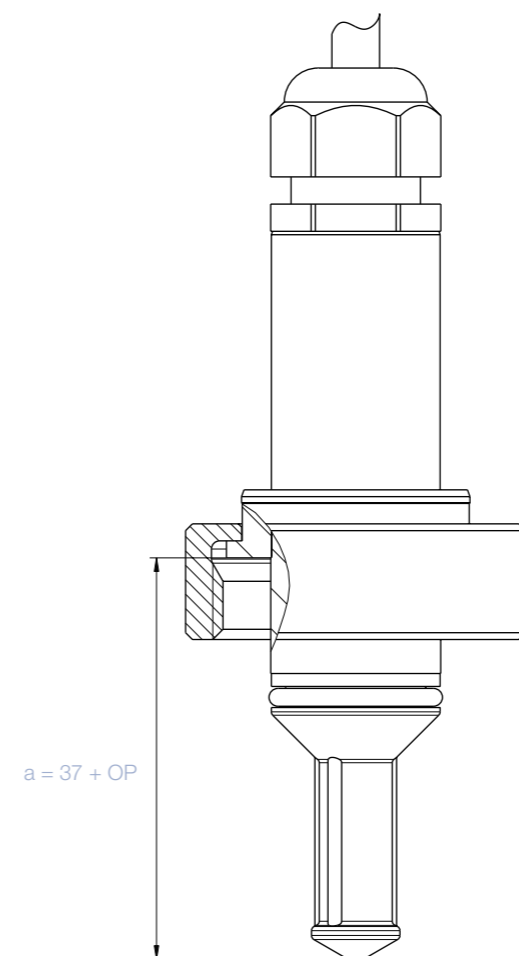

Specifications

Measuring range	0.1 µS/cm – 500 mS/cm
Measurement Principle	4 pole contacting
O-ring position	22 mm – 55 mm
Process temperature	-20 – 135 °C
Pressure range (relative to ambient)	0 – 6 bar
Hygienic aspects	CIP, SIP
Cell constant	0.147/cm
Material of electrodes	Stainless steel 1.4435
O-ring	EPDM*

Other versions available on request

Ordering Information

	a-length	5 m Fix cable
Conducell 4US-G125	variable	237700-OP
Conducell 4US-T150-50	50	237750
Conducell 4US-T150-100	100	237760



Accessories



- **Flow-through cell PEEK TC 1.5"** Ref 237931
This flow through cell made of FDA approved PEEK facilitates insertion of Conducell 4US-T150-50 in pipework.

Conductivity Standards see page 92

Safety Socket see page 136



Conducell UPW



Specifications	
Measuring range	0.01 – 1500 µS/cm
Measurement Principle	2 pole contacting
Process temperature	Arc: analog 0 – 110 °C, digital 0 – 130 °C
Pressure range (relative to ambient)	0 – 10 bar (130 °C)
Hygienic aspects	Autoclavable, CIP, SIP
Cell constant	< 0.1/cm
Material of electrodes	Stainless Steel DIN 1.4435
Surface quality	R _a < 0.4 µm (N5)
O-ring	EPDM*

Other versions available on request

The Conducell UPW 2-pole conductivity sensors are designed for the use in liquids with very low conductivity, i.e. Ultra Pure Water, Pure Water and Water for Injection, particularly in the pharmaceutical and chemical industry.

Conducell UPW sensors are available with different process connections such as TriClamp 1.5", PG 13.5.

All plastic materials are compliant with the order EU 10/2011.



“Did you know... that with Arc all the important information is stored in the sensor head?”

Benefits

- ▶ Sanitary design: all wetted parts are FDA approved
- ▶ Easy cleanable
- ▶ Intelligence in the sensor: fully compensated measurement signals
- ▶ Easy handling due to user-friendly interface

Typical applications

- ▶ Ultra Pure Water
- ▶ Pure Water
- ▶ Water for Injection

Ordering Information

	a-length	VP6	Arc
Conducell UPW PG 13.5	120	243640	243579
Conducell UPW TC 1.5"	87	-	243578



UPW Simulator

Accessories



UPW Simulator Ref 243580
Traceable resistor to verify the Arc module acc. to USP <645>

Conductivity Standards see page 92

Cables see page 96

Arc Accessories see page 100

Housings see page 109



Conducell 2DC-PG



The Conducell 2DC sensor is constructed in a simple way and is best suited for measurements in clean solutions and non-critical applications. Contaminants, such as lime, will affect the measurement.

Benefits

- ▶ 2 large graphite electrodes for stable measurements
- ▶ Mechanically-stable plastic shaft
- ▶ Easily cleanable

Typical applications

- ▶ Water and Wastewater



Specifications

Measuring range	10 µS/cm – 20 mS/cm
Measurement Principle	2 pole contacting
Process temperature	-5 – 80 °C
Pressure range (relative to ambient)	0 – 6 bar
Cell constant	1/cm
Material of electrodes	Graphite
O-ring	EPDM*

Ordering Information



	a-length	5 m Fix cable
Conducell 2DC-PG 120	120	237610

Accessories



Conductivity Standards see page 92
Housings see page 109

Conducell I family



The inductive conductivity cell Conducell I is specifically designed for use in demanding applications in beverage and pharmaceutical industries and in biotechnology. Thanks to its food-grade PEEK body and its hygienic design it meets the demands of these industries.

Benefits

- ▶ Unique hygienic design, therefore no risk of contamination
- ▶ Made from non-corrosive materials which is good for acids and bases
- ▶ Fast temperature response time t90 under 26 s enable safe and efficient phase separations
- ▶ Insensitive to electrode soiling and polarization thanks to electrodeless, inductive measuring principle.

Typical applications

- ▶ Phase separation
- ▶ Control of CIP (cleaning in place)
- ▶ Leakage monitoring



Specifications

Measuring range	100 μ S/cm – 2000 mS/cm (uncompensated)
Measurement Principle	Inductive
Process temperature	-10 – 125 °C
Pressure range	0 – 8 bar (125 °C) 0 – 12 bar (90 °C)
Hygienic aspects	CIP, SIP
Cell constant	6.3/cm
Wetted Parts*	PEEK (FDA approved USP class VI, EU 10/2011)

Ordering Information

Conducell I Family Structure

243290	Code		Process Connection	
	1		Neumo BioControl D50	
	2		Triclamp 2"	
	3		Tuchenhagen Varivent® DN50/40	
		Code	Additional Certificate	
		1	None	
		2	Biocompatibility USP class VI	
		Code	Temperature Sensor	
		1	Pt1000	
	243290 -			

Accessories



Conductivity Standards see page 92
Housings see page 109

Cell Density

Biological processes are increasingly important in biotechnical and pharmaceutical industries. The variability of living organisms is often very high, making the culture process difficult to standardize. Extensive process optimization and control are required for stable cell cultures, fermentations and improved yield. Today bioprocess development relies on labor intensive sampling and offline measurements that also lack the necessary granularity to fully optimize the yield. The available online measurements of pH and dissolved oxygen are linked indirectly to the cell status and characteristics.

Online monitoring of cell density provides the continuous information necessary to optimize control and yield beyond what is possible offline. Hamilton now offers sensors for continuous cell density measurement. The Incyte permittivity sensor delivers information on viable cell density whereas the Dencytee sensor measures total cell density via turbidity. In combination with our advanced Arc pH and dissolved oxygen probes, permittivity and turbidity sensors provide all relevant information on the progress of mammalian, yeast and high density bacteria cultures. This enables better understanding and control of bioprocesses.

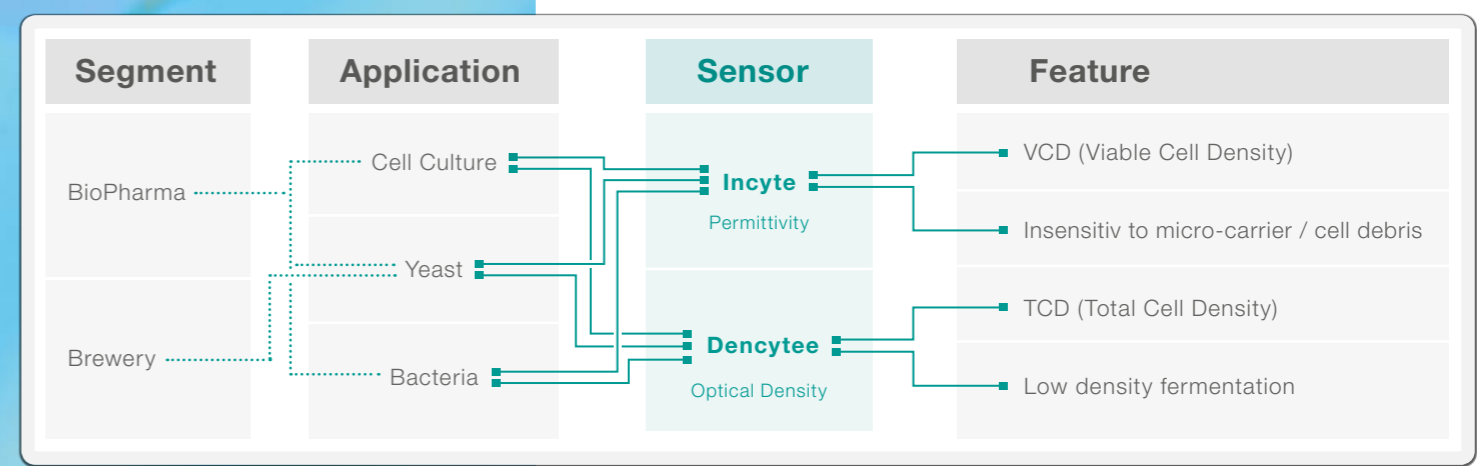



Accurately analyzing the characteristics of viable cells during bioprocess is crucial. Only viable and healthy cells are producing the product of interest. Today these characteristics are monitored by labor intensive offline samplings.

Analyzing cell characteristics online provides deep insight into the bioprocess. It allows stable process control, fast optimization and reduces the risk of sampling errors. The Incyte sensor is especially designed for measuring viable cells during mammal cell culture, yeast and high density bacterial fermentation.

The measurement principle of Incyte sensors is based on permittivity. Viable cells behave like little capacitors and their polarization and depolarization in an alternating electrical field is measured. This signal can be correlated to the viable cell density. This method is insensitive to cell debris and microcarriers because only viable cells can be polarized.

A measuring Unit consists of an Incyte sensor and a pre-amplifier, which converts the analog measurement to a stable digital signal. This unit has to be connected to the Arc View Controller, equipped with a required Incyte and optional Incyte scan license.

 *“Did you know... that Hamilton is the only provider of all relevant parameters for cell cultures & fermentations: viable cell density, pH and DO?”*

Benefits

- ▶ Specific for viable cells
- ▶ Suitable for cell culture and fermentation
- ▶ Insensitive to microcarriers and cell debris
- ▶ No more hidden events
- ▶ Optimization of feeding strategy and yield

Typical applications

- ▶ Eucaryotic cells
- ▶ Yeast
- ▶ High density bacteria fermentation



Specifications	
Measuring Range	5 x 10 ⁵ – 8 x 10 ⁹ cells/mL (Mammalian) 5 – 200 g/L dry weight (fermentation)
Conductivity range	Incyte LC: 0.5 – 10 mS/cm Standard: 2 - 50 mS/cm
Measuring principle	Permittivity
Process temperature	0 – 60 °C
Pressure range (relative to ambient)	0 – 12 bar (DN12) 0 – 3 bar (DN25)
Hygienic aspects	Autoclavable, CIP, SIP
O-ring	EPDM*

Ordering Information



	a-length	Unit*		Replacement Sensor	
		Standard	LC	Standard	LC
Incyte DN25 - SG	70	243710	–	243730	–
Incyte DN25 - DG	46	243711	–	243731	–
Incyte DN25 - DG BE	54	243712	–	243736	–
Incyte DN12	120	243700	243704	243732	243716
Incyte DN12	220	243701	243705	243733	243717
Incyte DN12	320	243702	243706	243734	243718
Incyte DN12	420	243703	243707	243735	243719

SG = Single Gasket (Standard DN25)
DG = Double Gasket (Sartorius / B.Braun)
DG BE = Double Gasket Bioengineering

* when purchased as Unit, sensor and pre-amp are factory calibrated
LC = Low Conductivity

Accessories



- Val/Cal Kit Incyte Ref 243740
- Solution B Ref 243742
- 10 m cable M12/M12 Ref 243871
- Val/Cal Kit Incyte LC Ref 243713
- Solution B LC Ref 243708
- 20 m cable M12/M12 Ref 243872
- Permittivity Simulator Ref 243743
- Incyte Pre-Amp Ref 243720
- 40 m cable M12/M12 Ref 243873
- Solution A Ref 238988
- 5 m cable M12/M12 Ref 243870

Dencytee



Accurate cell growth analysis during bioprocesses is essential. The Dencytee sensor is especially designed for monitoring total cell density during low density bacterial fermentation, as well as yeast and mammal cell cultivation.

As soon as the required amount of cells is reached, bio-production and analysis can begin. Monitoring total cell density requires offline sampling and analysis, which leads to delayed result information. By measuring this parameter online the cell growth rate can be determined quickly and accurately without the loss of any information. Dencytee sensors are based on optical density respectively the turbidity of a suspension at NIR (near-infra red) wavelengths. All particles and molecules that scatter the NIR light will be detected and can be correlated to the total cell density. The sensor keeps the light intensity at the detector constant, which leads to a broader measuring range.

A measuring Unit consists of a Dencytee sensor, available in different lengths, and a pre-amplifier. This unit has to be connected to the Arc View Controller, equipped with a required Dencytee license.

 *“Did you know... that Dencytee is the only optical density sensor that works with a constant light intensity at the detector?”*

Benefits

- ▶ Wide linear measuring range
- ▶ LED provides long lifetime

Typical applications

- ▶ Low density fermentation

Specifications

Measuring Range	10 ⁵ – 7 x 10 ⁸ cells/mL (Mammalian) 0.5 – 100 g/L dry weight (fermentation)
Optical density 880	0 - 2500
Measuring principle	Optical density, Near Infrared (NIR, 880 nm)
Process temperature	0 – 80 °C
Pressure range (relative to ambient)	0 – 10 bar (25 °C)
Hygienic aspects	Autoclavable, CIP, SIP
Optical window	Sapphire glass
Optical path length	5 mm
O-ring	EPDM*

Ordering Information

	a-length	Unit*	Replacement Sensor
Dencytee	120	243755	243750
Dencytee	225	243756	243751
Dencytee	325	243757	243752
Dencytee	425	243758	243753

* when purchased as Unit, sensor and pre-amp are factory calibrated

Accessories



- Val/Cal Solution Dencytee Ref 243886
- Dencytee Pre-Amp Ref 243760
- 5 m cable M12/M12 Ref 243870
- 10 m cable M12/M12 Ref 243871
- 20 m cable M12/M12 Ref 243872
- 40 m cable M12/M12 Ref 243873



Arc View Controller



In order to understand a biological process, all relevant parameters must be plotted on a graph to be interpreted. This is done manually after ending a process run or continuously with a process control system.

It is now possible to display all relevant parameters of a bioprocess simultaneously on a screen and also directly at the fermenter. The Arc View Controller, ComBox, and Cell Density Integration Kit (CDIK) are specifically designed for viable and total cell density measurements and supports Hamilton's wireless Arc-technology to graph and record pH and DO measurements. This allows process analysis directly on site.

The Controller stores the calibration and recorded data of the Incyte and Dencytee units. When the recorded data of the connected units is displayed, errors or failures will be detected, reported and an alarm initiated. A software license is required for the use of the specific Controller for Incyte and Dencytee; an additional license will also be needed if options such as the Incyte Scan or OPC are selected. A new feature provides the option to graph Arc pH and dissolved oxygen sensors on the same screen. The signals can be sent wirelessly directly from the sensors, equipped

with the Arc Wi adapter, to the Arc wireless converter connected to the Controller. The Arc View Controller is available with 2 or 4 wired input channels for cell density, and additionally two inputs of Arc sensors for every wired channel. Two screen sizes are available and data output can be Modbus, OPC or 4-20 mA (AUX).

The ComBox is a compact alternative to the Arc View Controller 265 and is designed to easily fit minimal space requirements. It is operated by a simple connection to an existing computer. The Cell Density Integration Kit is designed to allow easy integration into skid fermenter controllers or production cabinets.

Benefits

- ▶ All relevant parameters for cell culture and fermentation can be shown at once
- ▶ Various different outputs ensure compatibility to process control systems
- ▶ Immediate automatic re-start after power failure ensures minimum loss of data
- ▶ Data of several runs can be stored and copied on a USB stick
- ▶ Different licenses for different customers' needs

Specifications

Measured variable	Conductivity, permittivity, optical density
Calculated variable	Viable cell density, total cell density
Analog output	AUX to Analog Output Box 4-20 mA
Digital outputs	Modbus RTU (RS485), Ethernet RJ45 (OPC XML-DA)
Digital inputs	USB for downloading data and firmware upgrade
Dimensions (W x D x H)	Arc View 265: 280 x 240 x 115 mm Arc View 465: 296 x 240 x 115 mm Arc View 465 XL: 443 x 364 x 114 mm ComBox: 190 x 85 x 56 mm
Display	Arc View 265/465: 5.7" color display Arc View 465 XL: 12" color display Virtual keyboard ComBox: none
Housing material	Stainless Steel 1.4435
Measuring Channels	Arc View 265: 2 Arc View 465/465 XL: 4 ComBox: 2
Operating humidity	0 – 80%
Ambient temperature	-10 – 45 °C
Power supply	24 VDC-power adapter 110 – 240 VAC to 24 VDC

Ordering Information

Choose Controller		Choose License			
243800	Arc View 265	Code	Incyte License		
243801	Arc View 465		1	yes	
243802	Arc View 465 XL		0	no	
243810	ComBox			Code	Incyte Scan License*
			1	yes	
			0	no	
				Code	Dencytee License
			1	yes	
			0	no	
				Code	OPC License
			1	yes	
			0	no	
2438xy –					← Order Code
243809	CDIK				

*requires Incyte License

Accessories



- **Incyte License** Ref 243822
- **Incyte Scan License** Ref 243823
- **Dencytee License** Ref 243824
- **OPC License** Ref 243820
- **4-20 mA Output Box** Ref 243850
- **5 m cable M12/Open end** Ref 243851
- **10 m cable M12/Open end** Ref 243852
- **Arc View Controller Profibus** Ref 243889

DO

The partial pressure of dissolved oxygen (DO) plays an important role in many biological, chemical and physical processes. Respiration in a lung or a leaf depends on the differences of the partial pressure as well as fermentation of substrates by yeast or bacteria. The amount of dissolved oxygen is also important for the safety and the quality of many other industrial processes.

The most common technologies to measure DO are the classical amperometric and the modern optical method. Classical amperometric Clark cells, where cathode and anode are separated from the sample by a gas permeable membrane, generate an electrical current proportional to the oxygen partial pressure of dissolved oxygen. The oxygen is reduced in the sensor, catalyzed by an electrolyte at a platinum cathode. At the anode silver is oxidized. In contrast to the Clark cells the optical measurement is based on the luminescence of a luminophore that absorbs photons and releases a part of the absorbed energy by emission of photons with a higher wavelength. Oxygen quenches this process by transferring the energy partially by collision. The more oxygen present the more quenching is observed. Hamilton measures the phase shift between excitation and emission across a population of light pulses in order to achieve the highest accuracy and widest operating range. The difference in the intensity of both waves is used for online sensor diagnostics.

Segment / Application	Sensor	Feature
Waste Water	Oxysens	Optical / Flow independent
Bio Pharma	VisiFerm DO	Optical / Atex / IECEx
Chem Pharma	VisiTrace DO	Cl ₂ resp. ClO ₂ resistant
Boiler Feed Water	VisiPro DO Ex	2-wire HART 4-20 mA
Brewery / Beverage	OxyFerm FDA	Amperometric
	OxyGold G	Trace level
	OxyGold B	



VisiPro DO

family



Specifications	
Measuring range	4 ppb – 25 ppm (DO)
Measurement Principle	Oxygen dependent luminescence quenching
Process temperature	-20 – 140 °C, the sensor provides no DO reading above 85 °C
Analogue interface	Two wire sink needs to be powered by external power supply
Operating voltage	18 – 30 VDC
Pressure range (relative to ambient)	-1 – 12 bar
Hygienic aspects	CIP, SIP
Surface Quality	R _a < 0.4 µm (N5)
Material	Stainless steel 1.4435
O-ring	EPDM*

The VisiPro DO is the optical dissolved oxygen (DO) sensor for use in explosive environment. VisiPro DO optical technology improves the measuring performance and simplifies maintenance. Improvements compared to conventional electrochemical (amperometric) sensors include flow independence, rapid start-up with no polarization time, and simplified maintenance.

With their integrated transmitter, VisiPro DO sensors enable direct communication to the process control system via 2 wire 4-20 mA standard signal or digital HART. All relevant sensor data including calibration and diagnostic information are stored in the sensor head, simplifying calibration and maintenance. Additional wireless communication directly from the sensor to your computer simplify laboratory calibration, configuration, and maintenance.



“ Did you know... that Hamilton invented the first optical DO sensor with ATEX / IECEx approval? ”

Benefits

- ▶ Reliable and robust optical measurement in hazardous environments
- ▶ Easy installation with 2-wire connection
- ▶ Laboratory calibration possible with HDM
- ▶ Direct analog or digital HART communication to the process control system via 4-20 mA signal

Typical applications

- ▶ ATEX environment
- ▶ Fermentation

Ordering Information

VisiPro DO Family Structure			
243667	Code	Ex	
	1	Ex	
	2	Non Ex	
		Code	a-length (mm)
		1	120
		2	160
		3	225
		4	325
		5	425
		Code	ODO Cap
		1	H0
	2	H2	
243667 –			← Order Code

ODO Cap H0: For general application in biotechnology, water treatment and monitoring as well as in breweries, wineries and soft drink processing.

ODO Cap H2: The ODO Cap H2 is designed for fermentation processes where sterilization in place (SIP) is performed in media containing higher amounts of lipophilic compounds. It comes with a hygienic design.

Accessories



- **ODO Cap H0 Kit** Ref 243515 **Cables** see page 96
- **ODO Cap H2 Kit** Ref 243505 **Housings** see page 109



VisiTrace DO



Specifications

Measuring range	0 – 2000 ppb
Measurement Principle	Oxygen dependent luminescence quenching
Response time $t_{98\%}$	< 20 s in gas; < 90 s in water
Process temperature	-10 – 140 °C, the sensor provides no DO reading above 85 °C
Operating voltage	18 – 30 VDC
Pressure range (relative to ambient)	-1 – 12 bar
Hygienic aspects	CIP, SIP
Surface Quality	$R_a < 0.4 \mu\text{m}$ (N5)
Material	Stainless steel 1.4435
O-ring	EPDM*

The VisiTrace DO is designed to measure dissolved oxygen in the low ppb ranges in brewing applications, notably during filtration, and filling. In addition, the special designed ODO Cap L0 for breweries is stabilized against standard disinfectant solution with active chlorine and chlorine dioxide. This is powerful during measurements in breweries, which may not allow for calibration after every CIP.

With the transmitter integrated, the intelligent VisiTrace DO sensor provides more reliable measurements directly to your process control system via the 4-20 mA output. The also integrated Bluetooth 4.0 wireless interface may be used for monitoring, configuration and calibration, and saves time without compromising quality.



“Did you know... that the VisiTrace DO is the only optical DO sensor that withstands chlorine and chlorine dioxide for a long time?”

Benefits

- ▶ For measurements from 0 - 2000 ppb
- ▶ Stable against chlorine and chlorine dioxide
- ▶ Rapid start-up with no polarization
- ▶ Flow and CO₂ independent readings
- ▶ Robust design for high flow rates

Typical applications

- ▶ Breweries
- ▶ Power Plants

Ordering Information

	a-length	M12
VisiTrace DO	120	243560
	225	243561



ODO Cap L0: The LO cap is designed for trace level measurements of dissolved oxygen in breweries, water de-aeration and power plants.

Accessories



- **ODO Cap L0 Kit** Ref 243530
- **Calibration station** Ref 243575

Cables see page 96
Housings see page 109



VisiFerm DO family

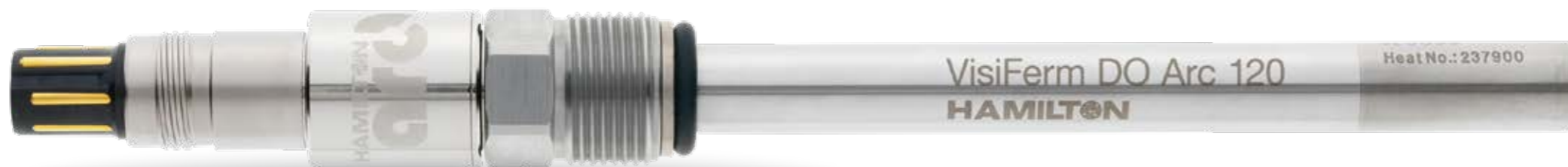

Specifications

Measuring range	4 ppb – 25 ppm (DO)
Measurement Principle	Oxygen dependent luminescence quenching
Response time $t_{98\%}$	< 30 s at 25 °C, from air to nitrogen
Process temperature	-10 – 140 °C, the sensor provides no DO reading above 85 °C
Operating voltage	7 – 30 VDC max. 1 W
Pressure range (relative to ambient)	-1 – 12 bar
Hygienic aspects	Autoclavable, CIP, SIP
Surface Quality	$R_a < 0.4 \mu\text{m}$ (N5)
Material	Stainless steel 1.4435
O-ring	EPDM*

The VisiFerm DO is the first optical oxygen sensor with integrated opto-electronics, having the full functionality of a measuring device with self-diagnostics. It is steam sterilizable, autoclavable and CIP compatible. The VisiFerm requires less maintenance than a classical oxygen sensor as it does not have a mechanically sensitive membrane or a corrosive electrolyte.



“Did you know... that Hamilton invented the first optical DO sensor in 12 mm format?”

Benefits

- ▶ No fragile membrane – with a solid sensor cap
- ▶ No polarization time required
- ▶ Instantly stable values, low drift, quick response
- ▶ Electrolyte-free, so no leakage
- ▶ Convenient precalibration in the laboratory, because data is stored in the sensor head

Typical applications

- ▶ Ethanologenic fermentation
- ▶ Biotechnical fermentation
- ▶ Brewery fermentation, filtration, filling
- ▶ Proactive corrosion control in HVAC systems

Ordering Information

VisiFerm DO Family Structure

243666	Code		Interface	
	1		Arc	
	2		ECS	
		Code	a-length (mm)	
		1	120	
		2	160	
		3	225	
		4	325	
		5	425	
			Code	ODO Cap
			1	H0
			2	H2
243666 –				← Order Code

ODO Cap H0: For general application in biotechnology, water treatment and monitoring as well as in breweries, wineries and soft drink processing.

ODO Cap H2: The ODO Cap H2 is designed for fermentation processes where sterilization in place (SIP) is performed in media containing higher amounts of lipophilic compounds. It comes with a hygienic design.

Accessories



- **ODO Cap H0 Kit** Ref 243515
- **ODO Cap H2 Kit** Ref 243505

Cables see page 96
Arc Accessories see page 100
Housings see page 109



OxyFerm FDA



The OxyFerm FDA is an electrochemical oxygen sensor suited for applications with high demands for hygiene, e.g. in pharmaceutical industry, in biotechnology and in food & beverage production. It is available with 12 mm or 25 mm (XL) shaft diameter.

The sensor is equipped with a FDA approved membrane for use in hygienic processes. It withstands steam sterilization, autoclavation and CIP cleanings.

Benefits

- ▶ Sanitary Feature: The silicone membrane seals without a gap to steel membrane body (no additional o-ring)
- ▶ Little drift, fast response, short polarization time
- ▶ Replacing the cathode is possible and very simple to perform.

Typical applications

- ▶ ATEX environment
- ▶ Fermentation

Specifications

Measuring range	10 ppb – 40 ppm (DO)
Response time $t_{99\%}$	< 60 s at 25 °C, from air to nitrogen
Process temperature	0 – 130 °C (Arc: analog 0 – 110 °C, digital 0 – 130 °C)
Pressure range (relative to ambient)	0 – 4 bar
Hygienic aspects	Autoclavable, CIP, SIP
Electrolyte	Oxlyte
Surface Quality	$R_a < 0.4 \mu\text{m}$ (N5)
Current in air at 25°C	40 – 80 nA
Material	Stainless steel 1.4435
Polarization voltage	-670 mV
O-ring	EPDM*

Ordering Information



	a-length	T82	VP 6	Arc	MS
OxyFerm FDA	120	237450	237540	243100	237713
	160	237455	237541	243101	–
	225	237452	237542	243102	237715
	325	237453	237543	243103	–
	425	237454	237544	243104	–
OxyFerm FDA XL	56	237175-OP	–	243140-OP	–
	150	237170	–	–	–
	300	237174	–	–	–
OxyFerm CIP	120	243289	–	–	–

With the XL option, the o-ring position can be optimally matched to the weld-in socket from 22 to 55mm. Please state the OP you need when ordering.

Accessories



- **Membrane Kit FDA** Ref 237140
- **Membrane Kit CIP** Ref 237126
- **Membrane Kit** Ref 237123
- **Oxlyte 30 mL** Ref 237118

- **Replacement Cathode OxyFerm** Ref 237306
- **Autoclavation Cap Oxyferm** Ref 242000
- **Polarization Module G** Ref 237350
- **Polarization Module T** Ref 237370

- **Cables** see page 96
- **Arc Accessories** see page 100
- **Housings** see page 109



OxyGold B



Specifications

Measuring range	8 ppb – 40 ppm (DO)
Response time $t_{99\%}$	< 60 s at 25 °C, from air to nitrogen
Process temperature	0 – 100 °C (Arc and VP6)
Pressure range (relative to ambient)	0 – 12 bar
Hygienic aspects	CIP
Electrolyte	Oxlyte B
Surface Quality	$R_a < 0.4 \mu\text{m}$ (N5)
Current in air at 25°C	180 – 500 nA
Material	Stainless steel 1.4435
Polarization voltage	0 mV
O-ring	EPDM*

The OxyGold B is an electrochemical oxygen sensor especially designed for applications which contain carbon dioxide like the production of beer, sparkling wine or soft drinks. The sensor is not affected by acidic gases.

Apart from the production of sparkling beverages, the OxyGold B can be used in all production processes where CO₂ might be an issue for electrochemical sensors.



“ Did you know...
that the OxyGold B is the only
sensor in the market with a
polarization voltage of 0 mV? ”

Benefits

- ▶ No cross-sensitivity with CO₂
- ▶ Only very little flow required
- ▶ Pressure and CIP resistant
- ▶ Replacing the cathode is possible and very simple to perform.

Typical applications

- ▶ CO₂ recovery
- ▶ Water de-aeration

Ordering Information



	a-length	VP 6	Arc
OxyGold B	120	237180	243115
	225	237185	243116

Accessories



- OxyGold Membrane Kit Ref 237135
- Oxlyte B 30 mL Ref 237138
- Polarization Module B Ref 237360
- Replacement Cathode OxyGold B Ref 237437

Cables see page 96

Arc Accessories see page 100

Housings see page 109



OxyGold G



The OxyGold G is an electrochemical oxygen sensor designed for processes in which very small amounts of oxygen have to be traced, like in the pharmaceutical or microelectronics industry. It is also suitable for processes where high pressures are applied.

Benefits

- ▶ Trace level measurement
- ▶ Suitable for use at high temperatures and high pressures during sterilization and CIP
- ▶ Little flow sensitivity
- ▶ Replacing the cathode is possible and very simple to perform.

Typical applications

- ▶ Boiler Feed Water
- ▶ Microelectronics

Specifications

Measuring range	1 ppb – 40 ppm (DO)
Response time $t_{99\%}$	< 60 s at 25 °C, from air to nitrogen
Process temperature	0 – 130 °C (Arc: analog 0 – 110 °C, digital 0 – 130 °C)
Pressure range (relative to ambient)	0 – 12 bar
Hygienic aspects	Autoclavable, CIP, SIP
Electrolyte	Oxlyte G
Surface Quality	$R_a < 0.4 \mu\text{m}$ (N5)
Current in air at 25°C	180 – 500 nA
Material	Stainless steel 1.4435
Polarization voltage	-670 mV
O-ring	EPDM*

Ordering Information

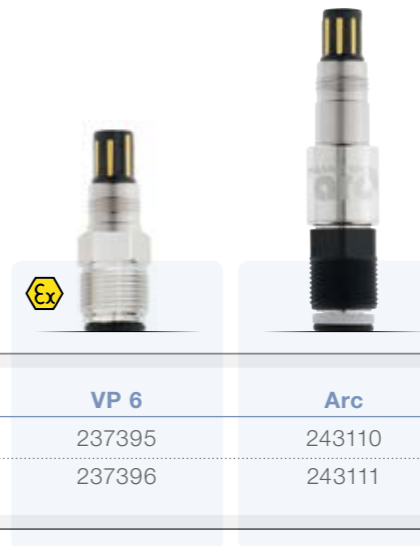

	a-length	VP 6	Arc
OxyGold G	120	237395	243110
	225	237396	243111

Accessories



- OxyGold Membrane Kit Ref 237135
- Oxlyte G 30 mL Ref 237139
- Polarization Module G Ref 237350
- Replacement Cathode OxyGold G Ref 237427

Cables see page 96

Arc Accessories see page 100

Housings see page 109



Oxysens



The Oxysens is an electrochemical oxygen sensor designed for applications in water, e.g. wastewater treatment, swimming pools or fish farms. It is easy to maintain, because the membrane and the electrolyte do not need to be replaced.

The response time of the Oxysens is fast, it is almost independent to flow and insensitive to soiling.

Benefits

- ▶ Maintenance-free DO sensor, no change of membrane or electrolyte
- ▶ Robust design
- ▶ Insensitive to soiling
- ▶ Short polarization and response times

Typical applications

- ▶ Water and Wastewater
- ▶ Fish farming

Specifications

Measuring range	40 ppb – 40 ppm (DO)
Response time $t_{99\%}$	< 60 s at 25 °C, from air to nitrogen
Process temperature	0 – 60 °C
Pressure range (relative to ambient)	0 – 4 bar
Electrolyte	Oxylyte
Surface Quality	$R_a < 0.8 \mu\text{m}$ (N6)
Current in air at 25°C	40 – 80 nA
Material	Stainless steel 1.4435
Polarization voltage	-670 mV
O-ring	EPDM*

Ordering Information



	a-length	5 m fix cable
Oxysens	120	237150

Accessories



- **Immersing Set** Ref 237158
The Immersing Set sheaths and protects 120mm sensors such as Oxysens while immersed in streams or channels.

Housings see page 109



USP
Class VI



Born with a Purpose

Beverly is designed for at-line and laboratory use in small and midsize breweries as well as in the beverage industry to provide excellent reliability in a rugged design, and purpose built to handle the environmental extremes encountered in everyday brewing operations.

Superior performance at an affordable price is achieved using Hamilton's best in class optical sensor VisiFerm DO with built-in intelligence, making Beverly the brewer's best friend.



Ordering Information

Type	Ref
Beverly	817100

Benefits

- ▶ Efficiency and serviceability bred from VisiFerm DO optical sensors
- ▶ Built to endure IP 67 watertight standards
- ▶ Stamina for 50 hours of continuous operation
- ▶ Fast response time down to ppb level
- ▶ Calibration without removing the sensor

Powered
by VisiFerm
DO



Portable DO Measurement

Measure DO in the bottle or can

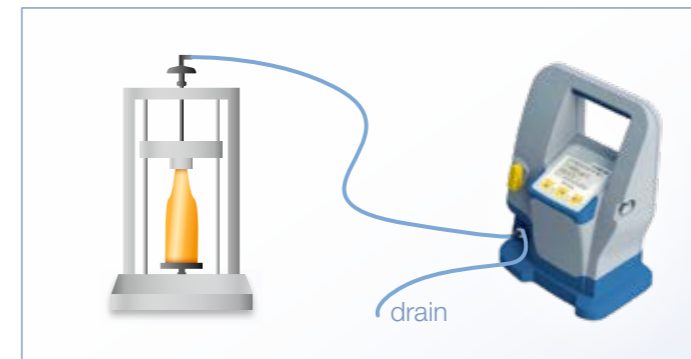

Measure DO during or after filtration

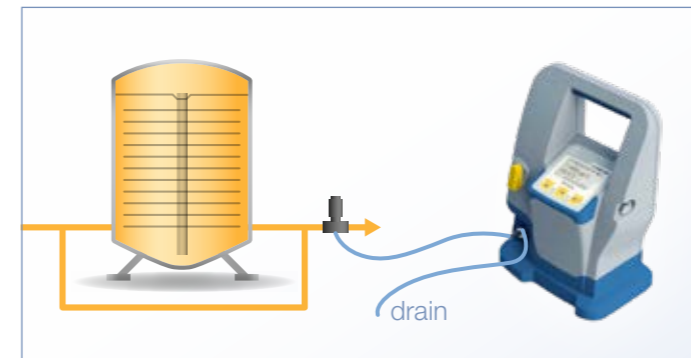

Check DO of bright beer tank prior to bottling

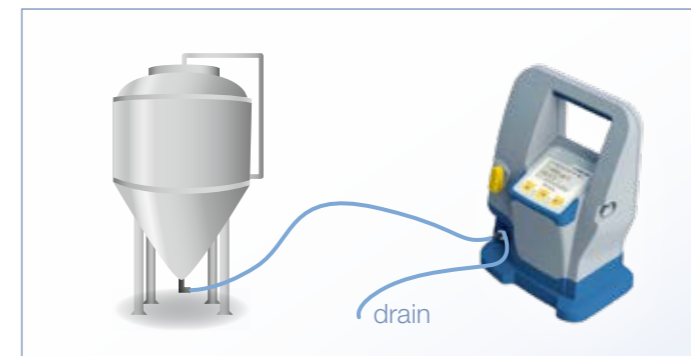

Beverly can be used as shown in the pictures and even beyond. An additional application is to check the oxygen content of the exhaust gas of vessels while flushing with CO₂ after cleaning and prior to filling. Measuring the oxygen at this point can help to save time and CO₂. Even if Beverly stays connected to a pipe or a vessel while CIP is running it's robust stainless steel flow cell prevents damage.

Specifications

Operating temperature range	0 – 80 °C (media) 0 – 40 °C (environment)
Operating pressure range	0 – 10 bar
Dimensions (B x W x H)	222 x 142 x 322 mm
Ø O.D. Barbed hose fittings	8 mm
Weight	4.7 kg
Protection rate	IP67
Battery	50 h (continuous operation)
Measuring range	4 ppb – 25 ppm (DO)
Accuracy at 25 °C	1 ± 0.05%-vol; 21 ± 0.2%-vol
Measurement principle	Oxygen dependent luminescence quenching
Response time t _{98%}	< 30 s at 25 °C, from air to nitrogen

Accessories



- **VisiFerm DO** Ref 243666-211
- **ODO Cap Kit H0** Ref 243515
- **Hoses** Ref 817134
- **Power supply** Ref 817804
- **Torx screwdriver** Ref 817145

Buffer Solutions you can Trust

All calibration procedures assume that the labeled values of the calibration buffers are correct. But buffer values can change over time and so can your results. A complete range of patented buffer solutions provides pH stability up to 5 years, something never achieved before. The pH buffers 9.21 and 10.01 are even stable when exposed to air. High buffering capacity provides rapid, stable calibration. The growth of fungus and micro-organisms is prevented.



Traceability

An important issue for the production of Certified Reference Materials is to ensure traceability through an unbroken chain of comparisons to reference material of the highest metrological quality (Primary Reference Material) from NIST¹ and PTB². Unlike other manufacturers, where only top-down traceability is applied, Hamilton works with circular or closed-loop traceability, providing unique reliability of Hamilton DuraCal buffers.

Top-down traceability: At Hamilton, the pH value of DuraCal buffers is determined by comparison against two secondary reference buffer solutions from accredited suppliers of secondary reference materials. The solutions themselves are compared against primary reference solutions from PTB or NIST. The measurement uncertainties of every measurement comparison are known and documented.

Bottom-up traceability: To ensure the highest possible accuracy and full reliability of the pH value, a representative number of samples from every single production lot is verified by an external, independent and impartial DAkkS³ laboratory. The DuraCal samples are compared against secondary reference solutions from DAkkS and these are referenced themselves to primary reference solutions from PTB or NIST. At this stage, the traceability loop is closed. DAkkS provides Hamilton with a calibration certificate for every DuraCal production batch.

Certified reference material: Due to the complete traceability of the measurement procedure and the assignment of uncertainties to the particular testing steps, the buffers pH 4.01, 7.00, 9.21 and 10.01 are classified as "Certified Reference Material" (CRM).

Features

- ▶ Convenient 250 mL or 500 mL bottle with built-in calibration compartment
- ▶ Economical, only about 15 mL of buffer is used per calibration
- ▶ Certified pH value from a DAkkS laboratory accredited for pH measurement
- ▶ First class certificate with traceability to international standards
- ▶ Certificates available at www.hamiltoncompany.com
- ▶ Expiration date on the bottle
- ▶ Immune to microbial growth

1) NIST: National Institute of Standards and Technology, Gaithersburg, MD, USA

2) PTB: Physikalisch Technische Bundesanstalt, Braunschweig, Germany

3) DAkkS: Deutsche Akkreditierungsstelle GmbH (D-K-15186-01-00), Zentrum für Messen und Kalibrieren GmbH, Wolfen, Germany

pH Buffers

pH Value	Accuracy	Stability*	Certified By	Packaging Unit	Ref
1.09	±0.02	60	Hamilton	500 mL	238271
1.68	±0.02	60	Hamilton	500 mL	238272
2.00	±0.02	60	Hamilton	500 mL	238273
3.06	±0.02	60	Hamilton	500 mL	238274
4.01	±0.01/±0.02	24/60	DAkkS	250 mL	238317
4.01	±0.01/±0.02	24/60	DAkkS	500 mL	238217
4.01	±0.01/±0.02	24/60	DAkkS	3 x 500 mL	238917
4.01	±0.01/±0.02	24/60	DAkkS	5 L	238332
4.01	±0.01/±0.02	24/60	DAkkS	10 L	238194
4.01	±0.01/±0.02	24/60	DAkkS	1000 L	238895
5.00	±0.02	60	Hamilton	500 mL	238275
6.00	±0.02	60	Hamilton	500 mL	238276
7.00	±0.01/±0.02	24 / 60	DAkkS	250 mL	238318
7.00	±0.01/±0.02	24 / 60	DAkkS	500 mL	238218
7.00	±0.01/±0.02	24 / 60	DAkkS	3 x 500 mL	238918
7.00	±0.01/±0.02	24 / 60	DAkkS	5 L	238333
7.00	±0.01/±0.02	24 / 60	DAkkS	10 L	238188
7.00	±0.01/±0.02	24 / 60	DAkkS	1000 L	238896
8.00	±0.02	60	Hamilton	500 mL	238277
9.21	±0.02	60	DAkkS	250 mL	238319
9.21	±0.02	60	DAkkS	500 mL	238219
9.21	±0.02	60	DAkkS	3 x 500 mL	238919
9.21	±0.02	60	DAkkS	10 L	238216
9.21	±0.02	60	DAkkS	1000 L	238897
10.01	±0.02	60	DAkkS	250 mL	238321
10.01	±0.02	60	DAkkS	500 mL	238223
10.01	±0.02	60	DAkkS	3 x 500 mL	238923
10.01	±0.02	60	DAkkS	10 L	238187
10.01	±0.02	60	DAkkS	1000 L	238898
11.00	±0.05	24	Hamilton	500 mL	238278
12.00	±0.05	24	Hamilton	500 mL	238279
4.01/7.00/9.21	±0.01/±0.02	24/60	DAkkS	500 mL, mixed	238922
4.01/7.00/10.01	±0.01/±0.02	24/60	DAkkS	500 mL, mixed	238924

ORP Buffers

Value	Accuracy	Stability*	Certified By	Packaging Unit	Ref
271 mV	±5 mV	24	None	500 mL	238228
475 mV	±5 mV	24	None	250 mL	238322
475 mV	±5 mV	24	None	500 mL	238227

* in months after date of manufacturing

Simple handling for professional results

Step 1 Open bottle



Step 2 Fill calibration compartment



Step 3 Calibrate electrode



Step 4 Empty calibration compartment



Hamilton Conductivity Standards

Long-term stability and accuracy

For measurements in the low conductivity range stable and reliable calibration standards have been completely lacking up to now. Since a conductivity standard is not a buffer solution, the lower the value of the conductivity standard, the greater the effect of entry of CO₂ or contamination. Hamilton is the first manufacturer to offer patented conductivity standards of 1.3 and 5 μS/cm with a certified accuracy of ±1% and a lifetime of 1 and 3 years, respectively. The procedure for determining conductivity was developed in collaboration with DFM¹. Many metrological institutes choose Hamilton standards because of their unprecedented stability and independent verification by PTB. During an interlaboratory test among prestigious European metrological institutes (PTB, DFM, DAkks³) Hamilton standards were used as measurement solutions.



Hamilton is Different

Hamilton offers conductivity standards whose stability of ±1% is guaranteed over a lifetime of up to 3 years. They can be used repeatedly under the condition that the bottle is not left open for more than 1 hour in total.

A representative number of bottles from every batch are measured by DFM. Their value is recorded on the calibration certificate and on every bottle. DFM enjoys the highest prestige in Europe in the area of electrolytic conductivity and is equipped with an absolute measurement cell that was developed in collaboration with NIST, and is accredited by the Danish accreditation agency DANAK to a conductivity of 0.9 μS/cm. DFM and NIST⁴ have made comparisons of their measurement uncertainty and have confirmed in a series of scientific publications that the measurement accuracy is in each case the

same. Because no primary standards exist in the low conductivity range, measurements depend on absolute measurement cells which trace electrical conductivity back to the SI units: meter and volt. Testing of Hamilton standards is thus carried out on the most precise measurement apparatus in the world, and certified accordingly.



1) DFM: Danish Institute of Fundamental Metrology, Denmark
 2) PTB: Physikalisch-Technische Bundesanstalt, Braunschweig
 3) DAkks: Deutsche Akkreditierungsstelle
 4) NIST: National Institute of Standards and Technology, Gaithersburg MD, USA

Unique advantages:

- ▶ Remains stable for a minimum of 1 year for 1.3 μS/cm, and up to 3 years for all other values
- ▶ Certificate with calibration document from DFM (available at www.hamiltoncompany.com)
- ▶ Expiration date shown on every bottle
- ▶ Bottles are permitted to stay open for a total of 60 minutes

Stability of the Hamilton 5μS/cm Conductivity Standard over 36 months

Check measurement by PTB²

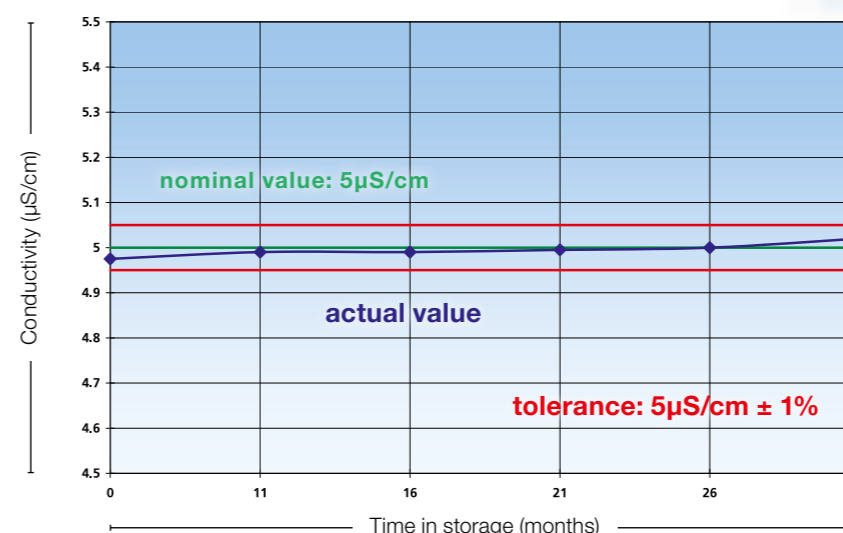

Value at 25°C	Accuracy	Stability*	Certificate From	Packaging Unit	Volume	Ref
1.3 μS/cm	±1%	12	DFM	Glass bottle	300 mL	238973
5 μS/cm	±1%	36	DFM	Glass bottle	300 mL	238926
15 μS/cm	±1%	36	DFM	Glass bottle	300 mL	238927
84 μS/cm	±1%	18	DFM	Calpack bottle	500 mL	238984
100 μS/cm	±1%	36	DFM	Glass bottle	300 mL	238934
147 μS/cm	±1%	18	DFM	Calpack bottle	500 mL	238985
706 μS/cm	±2%	36	Hamilton	Glass bottle	300 mL	238929
1413 μS/cm	±1%	36	DFM	Glass bottle	300 mL	238928
1413 μS/cm	±1%	18	DFM	Calpack bottle	500 mL	238986
12880 μS/cm	±1%	18	DFM	Calpack bottle	500 mL	238988
100 mS/cm	±1%	36	DFM	Glass bottle	300 mL	238935

* in months after date of manufacturing



Oxygen Accessories



OxyFerm Membrane Kit

The OxyFerm Membrane Kit contains 3 membrane bodies, Oxylyte electrolyte, pipette, spare o-ring and a polishing strip.

Ref	237123
-----	--------

Membrane Kit FDA

The Membrane Kit FDA is the kit for the OxyFerm FDA sensors and contains 3 FDA membrane bodies, Oxylyte electrolyte, pipette, spare o-ring and a polishing strip. The membrane body of the FDA membrane has a special rounded design to prevent accumulation of gas bubbles.

Ref	237140
-----	--------

Membrane Kit CIP

The Membrane Kit CIP contains 3 membrane bodies that are especially designed to withstand CIP cleanings. Oxylyte electrolyte, pipette, spare o-ring and a polishing strip.

Ref	237126
-----	--------

OxyGold Membrane Kit

The OxyGold Membrane Kit contains 3 membrane bodies with the rounded design, pipette and a spare o-ring. Electrolyte must be ordered separately to match the sensor (see page 95).

Ref	237135
-----	--------

Polarization Module

The Polarization Module is to prepare replacement sensors so that they can be used immediately for measurements without connection to a transmitter. It polarizes the oxygen sensors and saves polarization time at the transmitter.

Polarization Module T OxyFerm / OxyFerm FDA / OxyFerm XL	Ref 237370
Polarization Module G OxyFerm VP / OxyGold G	Ref 237350
Polarization Module B OxyGold B	Ref 237360

Replacement Cathode OxyFerm	Ref 237306
Replacement Cathode OxyGold G	Ref 237427
Replacement Cathode OxyGold B	Ref 237437

Autoclavation Cap

The Autoclavation Cap is used to protect the OxyFerm T82 connector from moisture during autoclavation. It is important to keep connections dry and clean to ensure reliable measurements.

Autoclavation Cap OxyFerm	Ref 242000
----------------------------------	------------

Electrolytes and Solutions



Electrolyte

Electrolytes for pH Sensors		Ref
3 M KCl	100 mL	238036
3 M KCl	500 mL	238936
Skylyte-CL	100 mL	242080
Protelyte	100 mL	238038
3 M KCl-LR	500 mL	238939
Skylyte	500 mL	238937

Electrolytes for Oxygen Sensors		Ref
OxyGold Oxylyte G	30 mL	237139
OxyGold Oxylyte B	30 mL	237138
OxyFerm Oxylyte	30 mL	237118

Storage Solution

In order to achieve long sensor life and faster electrode response times, it is recommended to store electrodes in our storage solution. It is an acid-buffered solution that ensures the regeneration of the electrode in addition to provide an optimized storage.

Storage Solution	500 mL	Ref 238931
-------------------------	--------	------------



Cleaning Solution Set

Depending on the type of application, the pH glass or diaphragm can get contaminated through various ingredients of the measuring solution. This is indicated by a slow response of the electrode, or even incorrect readings. To overcome these problems, Hamilton has developed a cleaning solution set. The intention is to have an overall cleaning of the pH glass as well as the diaphragm. The set is comprised of Cleaning Solution A, Cleaning solution B and a storage solution. To clean the electrode put it into each solution for 15 – 30 minutes, and your electrode will be ready for new measurements again.

Cleaning Solution Set	Ref 238290
------------------------------	------------



Cables for traditional and Memosens Sensors

For sensors with standard (S7) connector. Device side no connector (open end).

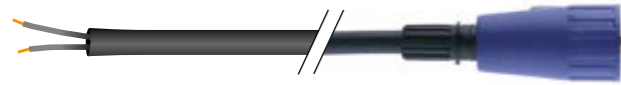

Length	Diameter	Ref
1 m	5 mm	355072
5 m	5 mm	355066
10 m	5 mm	355080

For sensors with standard (S7) connector. Device side BNC connector.



Length	Diameter	Ref
1 m	3 mm	355043
3 m	3 mm	355057
5 m	3 mm	355056

For sensors with standard (S7) connector. Device side DIN connector.



Length	Diameter	Ref
1 m	3 mm	355045
3 m	3 mm	355059

For sensors with K8 connector. Device side no connector (open end).



Length	Diameter	Ref
1 m	5 mm	355153
3 m	5 mm	355154
5 m	5 mm	355155
10 m	5 mm	355156

For sensors with K8 connector. Device side DIN connector.



Length	Diameter	Ref
1 m	5 mm	355157
2 m	5 mm	355158
3 m	5 mm	355159

For sensors with VP 6 connector. VP 6 single coaxial cable. Device side no connector (open end).



Length	Diameter	Ref
1 m	7,5 mm	355108
3 m	7,5 mm	355109
5 m	7,5 mm	355110
10 m	7,5 mm	355111
20 m	7,5 mm	355112

For sensors with T82/D4 connector, e.g. OxyFerm. Device side no connector (open end).

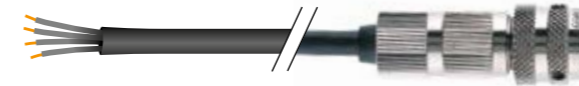

Length	Diameter	Ref
1 m	5 mm	355087
3 m	5 mm	355088
5 m	5 mm	355089
10 m	5 mm	355311

For sensors with T82/D4 connector, e.g. OxyFerm. Device side Lemo connector.



Length	Diameter	Ref
1 m	5 mm	355160
2 m	5 mm	355161
3 m	5 mm	355162
5 m	5 mm	355163

For sensors with Memosens connector. Device side no connector (open end).



Length	Diameter	Ref
1 m	6.3 mm	355350
3 m	6.3 mm	355351
5 m	6.3 mm	355352

Cables for Intelligent Sensors

Connection for Industrial Processes e.g. Production (see page 13)

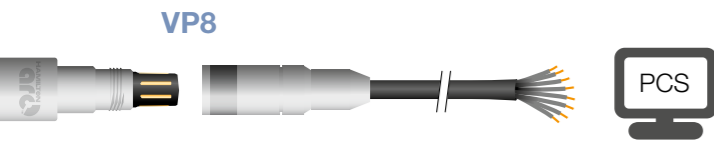

- Compatible with:**
- > VisiFerm DO family
 - > pH Arc family
 - > Conducell 4UxF family
 - > ORP Arc Sensors
 - > UPW Arc Sensors
 - > Conducell UPW Arc Sensors
 - > eDO Arc Sensor (e.g. OxyFerm FDA Arc)

Ref	Description	Interface
355263	1 m Data Cable VP8 / Open End	4-20 mA/Modbus
355264	3 m Data Cable VP8 / Open End	4-20 mA/Modbus
355265	5 m Data Cable VP8 / Open End	4-20 mA/Modbus
355266	10 m Data Cable VP8 / Open End	4-20 mA/Modbus
355267	15 m Data Cable VP8 / Open End	4-20 mA/Modbus
355268	20 m Data Cable VP8 / Open End	4-20 mA/Modbus
355217	1 m Cable VP8 / Open End	ECS mode*
355218	3 m Cable VP8 / Open End	ECS mode*
355219	5 m Cable VP8 / Open End	ECS mode*
355220	10 m Cable VP8 / Open End	ECS mode*
355221	15 m Cable VP8 / Open End	ECS mode*
355222	20 m Cable VP8 / Open End	ECS mode*

* VisiFerm DO family only

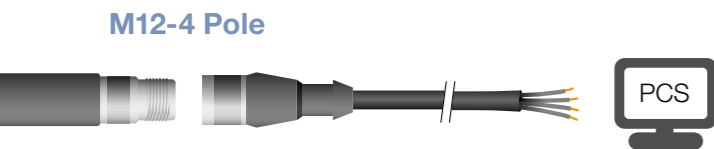

- Compatible with:**
- > VisiPro DO family
 - > VisiTrace DO family

Ref	Description
355283	3 m Cable M12-4 Pole / Open End
355284	5 m Cable M12-4 Pole / Open End
355285	10 m Cable M12-4 Pole / Open End

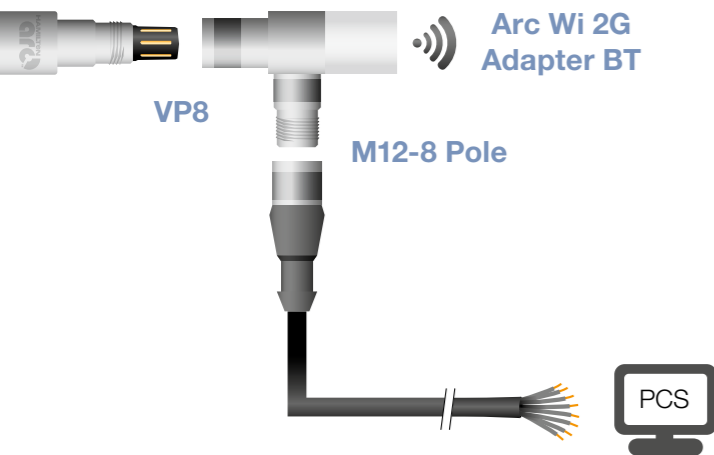

Ref	Description
355320	3 m Cable M12-8 Pole / Open End
355321	5 m Cable M12-8 Pole / Open End
355322	10 m Cable M12-8 Pole / Open End

Power Cables for Bio Controllers

Connection for old Bio Controllers or Transmitters in R&D (see page 15)



- Compatible with:**
- > VisiFerm DO ECS family

Power Cable 230 V / 110 V AC

Ref	Description
355298	1 m Power Cable VP8 / AMP
355258	4 m Power Cable VP8 / Binder
355297	1 m Power Cable VP8 / BNC
355296	3 m Power Cable VP8 / BNC
355245	2.5 m Power Cable VP8 / Lemo
355194	1 m Power Cable VP8 / Open End



- Compatible with:**
- > pH Arc family
 - > ORP Arc family

Power Cable 230 V / 110 V AC

Ref	Description
243168-XX	Arc ECS Adapter pH/ORP BNC
243169-XX	Arc ECS Adapter pH/ORP Open End



- Compatible with:**
- > Arc Sensors (Note: does not support VisiPro DO and VisiTrace DO family)

Ref	Description
242413-XX	Arc USB Power Cable
243490-01	2 m Arc USB Power Cable VP8
243490-02	2 m Arc USB Power Cable M12-8 Pole



- Compatible with:** VisiPro DO family / VisiTrace DO family

Ref	Description
355288	3 m Power Cable M12-4 Pole

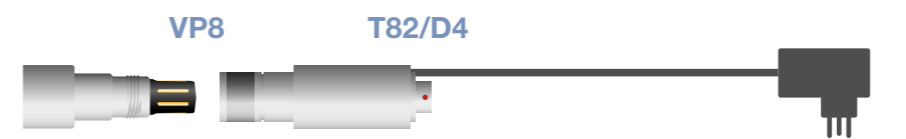

- Compatible with:** VisiFerm DO family

230 V / 110 V AC

Ref	Description
242413-XX	VisiFerm T82/D4-Power Adapter



The code XX in the product number defines the type of electrical power connector:
 01 – Power cord EU / 02 – Power cord CH / 03 – Power cord US / 04 – Power cord UK / 05 – Power cord AU/NZ

Arc Accessories

Arc View Mobile



This mobile device empowers the operator to monitor measurement values, calibrate Arc sensors and configure various parameters with a unified user interface for pH, DO, Conductivity and ORP. The Arc View Mobile device is based on the Samsung Galaxy Tab Active tablet and comes pre-configured with the ArcAir application, app blocker application, power supply cable, instruction manual and Hamilton quick guide.

Ref	243690
------------	--------

Modbus Profibus Converter



The Deutschmann Unigate® CL Module converts the Modbus protocol of the Arc and VisiFerm DO sensors into the Profibus DP protocol. All Arc parameters DO, pH, ORP and conductivity are supported. The conversion script is pre-installed.

Type	Ref
Modbus Profibus Converter	243555
Modbus Profibus Programmer's Manual	624719

Arc Wireless Converter BT



Designed for wireless communication between HDM (Hamilton Device Manager) and VisiPro DO Ex.

Ref	243499
------------	--------

Arc Wi 1G Adapter BT



The Arc Wi 1G Adapter BT is expanding the functionality of Arc sensors by providing wireless communication wire Bluetooth® 4.0 for local monitoring all analog and digital signals are bypassed through the Arc Wi 1G Adapter BT.

Ref	243460
------------	--------

Arc Wi 2G Adapter BT



The Arc Wi 2G adapter is expanding the functionality of Arc sensors by providing wireless communication for local monitoring in parallel to robust 4-20 mA signal, and simple sensor connection to the PCS with additional internal galvanic isolator for an enhanced signal quality.

Ref	243470
------------	--------

Hamilton Customized Products

Customized products for our customers' special needs

The adaptation of standard products to customer's special needs is the main focus of our application engineering team. Customizing can include modifications to length, insertion depth, process adaptation of the sensor or changing the housing to a different material. Many more adaptations are possible.



HAMILTON
CUSTOMIZED
PRODUCT

Need a custom housing or sensor? The Hamilton Customized Product Team is happy to help design products for your specific application. Give us a call to learn more.

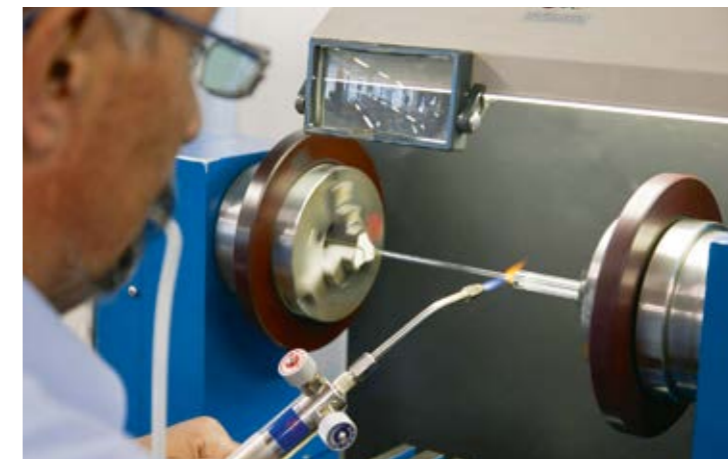

Transmitter H100



The H100 is a transmitter for universal use in the chemical industry, power stations, biotechnology, food processing and pharmaceutical industries as well as in water/wastewater treatment. Icons guide the operator and show the sensor status.

Sensor failures are detected, shown on the display and an alarm is set. Calibration can be done manually or by selecting standard calibration media. After each calibration the sensor data will be shown and evaluated. The H100 is easy to handle and can be mounted on the wall as well as on a panel.



User friendly, robust and reliable

Easy to install, operate and calibrate

- ▶ Large terminal compartment and pre-assembled rear unit for easy installation.
- ▶ The large display and intuitive menu structure ensure straightforward navigation.
- ▶ Icons supply operating messages and signal unusual states.
- ▶ Simple calibration with automatic buffer recognition.

Robust design

- ▶ Optional protective hood for additional protection against weather exposure and mechanical damage.
- ▶ Wall, post/pipe, or panel mounting possible with optional panel- or pipe-mount kit.

Reliable instrument for process applications

- ▶ The sensor status and potential defects are continuously monitored for real time display of error or alarm.
- ▶ Asymmetry potential, slope and response time are evaluated during calibration through the sensor lifetime for preventive maintenance indication.
- ▶ The integrated calibration timer automatically indicates when calibration is required.

Transmitter H100 pH

Specifications

Measured variable	pH, mV and temperature
Measuring range (pH / OPR)	-1500 – +1500 mV
Display range pH	-2.00 – 16.00
Measuring error	<0.02 pH, <1 mV
Temperature input	Pt 100, Pt 1000, NTC 30 kOhm
Temperature measuring range	-20.0 – +150 °C
Temperature resolution	0.1 °C
Calibration	1 point, 2 point and product calibration
Power supply	24 – 230 V AC/DC
Display	LC display, 7-segment with icons
Ambient temperature	-20 – 55 °C
Relative humidity	80 % at temperatures up to 55 °C
Ingress protection	IP 65, NEMA 4X
Alarm contact	Yes
Hold mode	Yes
FM	NI Class I, Div 2 Group A, B, C, D, T4 Ta = 55 °C; Type 2 NI Class I, Zone 2 Group IIC, T4 Ta = 55 °C; Type 2

Ordering Information

Type	Ref
H100 pH	243080-01



Accessories

- **Pipe-mount kit** Ref 243082
- **Panel-mount kit** Ref 243083
- **Protective hood** Ref 243084

Mounting plan

all dimensions in mm

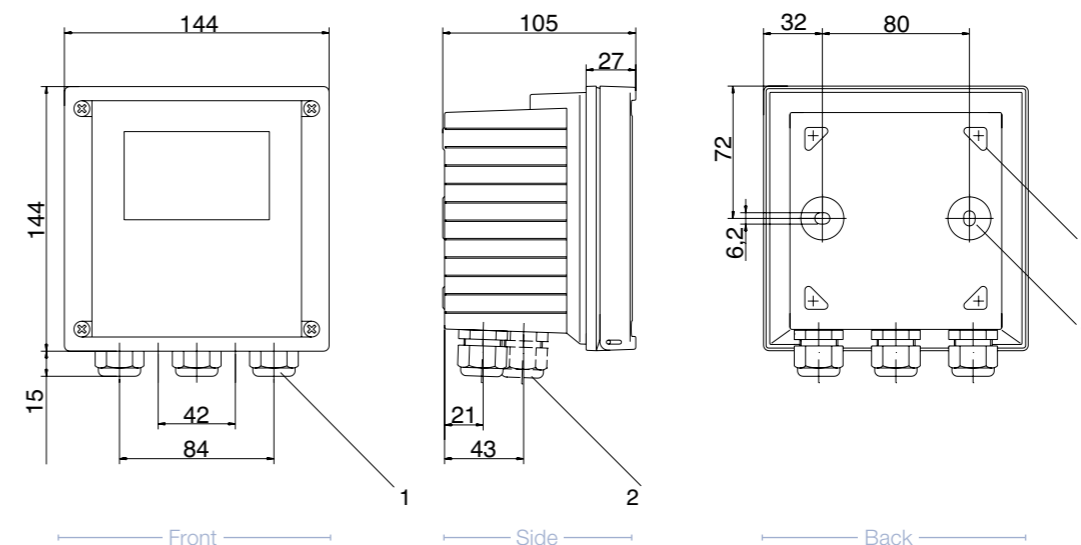

- 1 Cable gland (3x)
- 2 Knockouts for cable glands or ½" conduit (conduits not incl.)
- 3 Knockout for pipe mounting (4x)
- 4 Knockout for wall mounting (2x)

Cond

DO

Transmitter H100 Cond

Transmitter H100 DO

Specifications

Measured variable	Conductivity, resistivity, concentration, salinity, temperature
Measuring range conductivity	0 – 999.9 mS/cm
Effective range conductivity	0.2 µS x c – 1000 mS x c
Measuring range resistivity	0.00 – 99.99 MΩ x cm
Measuring range concentration	0.00 – 9.99 % by wt
Measuring range salinity	0.0 – 45 ‰ (0 – 35 °C)
Measuring error	< 1 % meas. val. + 0.4 µS x c
Temperature input	Pt 100, Pt 1000, NTC 30 kOhm
Temperature measuring range	Pt 100/Pt 1000: -20.0 – +200 °C NTC 30 kOhm: -20.0 – +150 °C
Temperature resolution	0.1 °C
Power supply	24 – 230 V AC/DC
Display	LC display, 7-segment with icons
Ambient temperature	-20 – 55 °C
Relative humidity	80 % at temperatures up to 55 °C
Ingress protection	IP 65, NEMA 4X
Alarm contact	Yes
Hold mode	Yes
FM	NI Class I, Div 2 Group A, B, C, D, T4 Ta = 55 °C; Type 2 NI Class I, Zone 2 Group IIC, T4 Ta = 55 °C; Type 2

Specifications

Measured variable	DO saturation, DO concentration
Measuring current	-2 – 1800 nA
O ₂ resolution	0.05 nA
O ₂ saturation	0 – 200 %
O ₂ concentration	0.00 – 20.00 mg/l / 0.00 – 20.00 ppm
Polarization voltage	0 – 1000 mV (User-defined)
Salinity correction	00.00 – 45.00 g/kg (User-defined)
Measuring error	< 0.5 % meas. val. + 0.5 %
Temperature input	NTC 22 kOhm, NTC 30 kOhm
Temperature measuring range	-20.0 – +150 °C
Temperature resolution	0.1 °C
Power supply	24 – 230 V AC/DC
Display	LC display, 7-segment with icons
Ambient temperature	-20 – 55 °C
Relative humidity	80 % at temperatures up to 55 °C
Ingress protection	IP 65, NEMA 4X
Alarm contact	Yes
Hold mode	Yes
FM	NI Class I, Div 2 Group A, B, C, D, T4 Ta = 55 °C; Type 2 NI Class I, Zone 2 Group IIC, T4 Ta = 55 °C; Type 2

Ordering Information

Type	Ref
H100 Cond	243080-02

Ordering Information

Type	Ref
H100 DO	243080-03



Accessories

- **Pipe-mount kit** Ref 243082
- **Panel-mount kit** Ref 243083
- **Protective hood** Ref 243084



Accessories

- **Pipe-mount kit** Ref 243082
- **Panel-mount kit** Ref 243083
- **Protective hood** Ref 243084

Mounting plan

all dimensions in mm

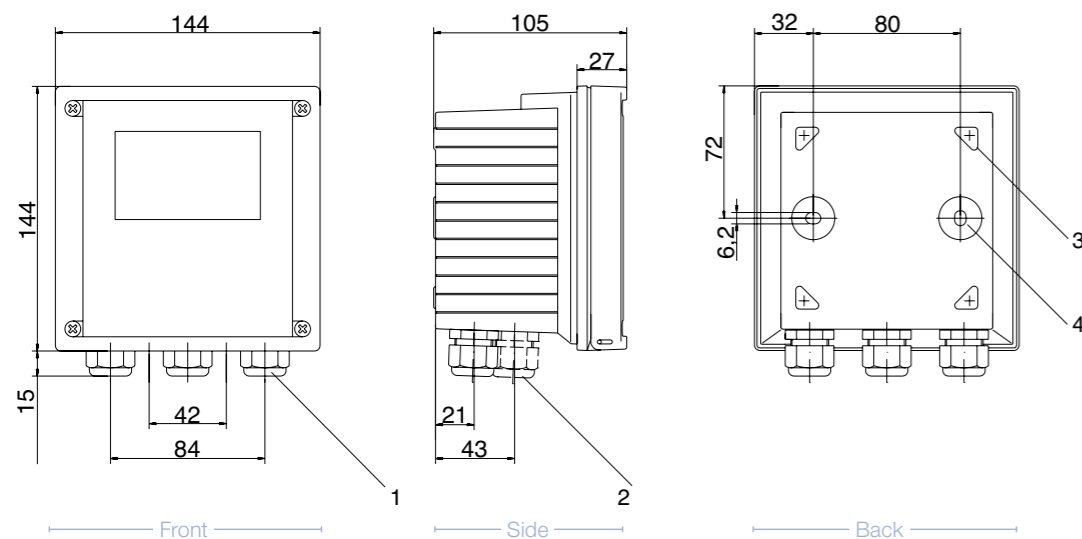

Mounting plan

all dimensions in mm

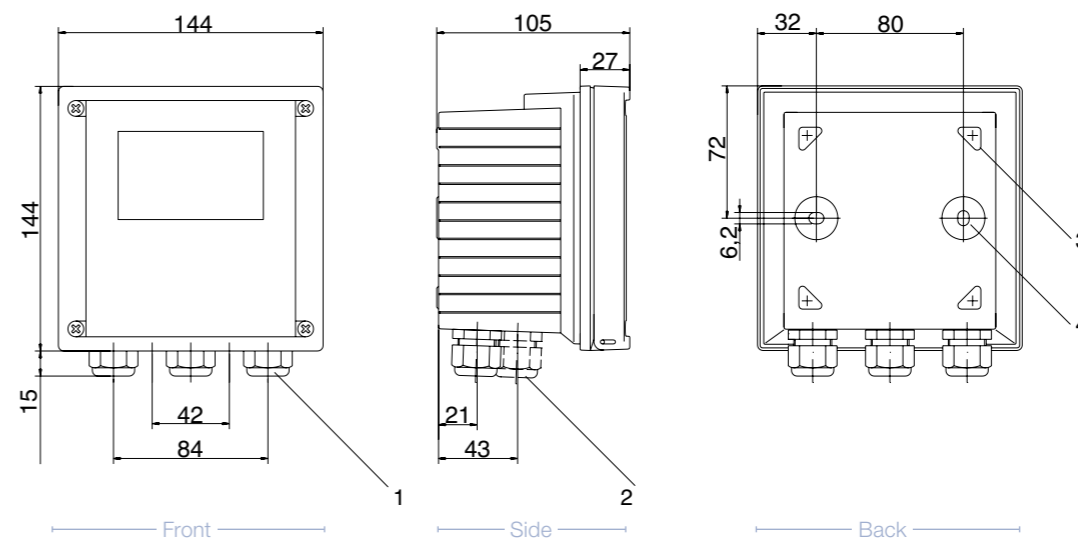

Transmitter H220X family



Hamilton H220X Transmitters combine ease of use and reliability. They are available in different configurations: Analog pH / ORP, Conductivity and inductive Conductivity as well as Memosens® pH and Oxygen.

It has been designed for universal process application including use in pharmaceutical, chemical, food & beverage industries as well as water / waste water treatment. The self-explaining user interface ensures comfortable and intuitive handling. Hamilton H220X transmitters provide continuous sensor monitoring and preventive maintenance indication for maximal reliability. The Memosens® Technology allows plug & play with pre-calibrated Memosens® sensors. Predictive maintenance system detects when a sensor has to be cleaned, calibrated or replaced.



The Transmitter H220X is available for the following parameters

- pH / ORP analog
- pH / ORP Memosens
- Conductive Conductivity analog
- Inductive Conductivity analog
- eDO Memosens

More info about measuring ranges, temperature ranges, input and output signals can be found on the Hamilton website.

Perfectly designed for hazardous areas and the Memosens® technology



Easy to install, operate and calibrate

- ▶ The large display and intuitive menu structure ensure straightforward navigation
- ▶ Simple calibration with automatic buffer recognition
- ▶ Memosens® sensors can be connected for even more simple handling



Robust design

- ▶ Suitable for Explosions protected areas (Ex II (1) 2G Ex ib [ia Ga] IIX T6/T4 Gb)
- ▶ Wall, post/pipe, or panel mounting possible
- ▶ Transmitter suitable for pollution degree 3



Reliable instrument for process applications

- ▶ Sensor status and potential defects are continuously monitored; errors and alarms are displayed in real time
- ▶ Asymmetry potential, slope and response time are evaluated during calibration through the sensor lifetime for preventive maintenance indication
- ▶ User-guided commissioning, graphic display and plain text guidance for maximum operating safety

Transmitter H220X Family Structure

243081	Code	Sensor Module
	1	Conductivity, Conductive Sensor
	2	Conductivity, Inductive Sensor
	3	Digital, Memosens pH, ORP
	4	Digital, Memosens eDO
5	pH or ORP (analog)	
	Code	Software
	1	Standard Version
	2	Advanced Version
243081 -		← Order Code

Mounting plan

all dimensions in mm

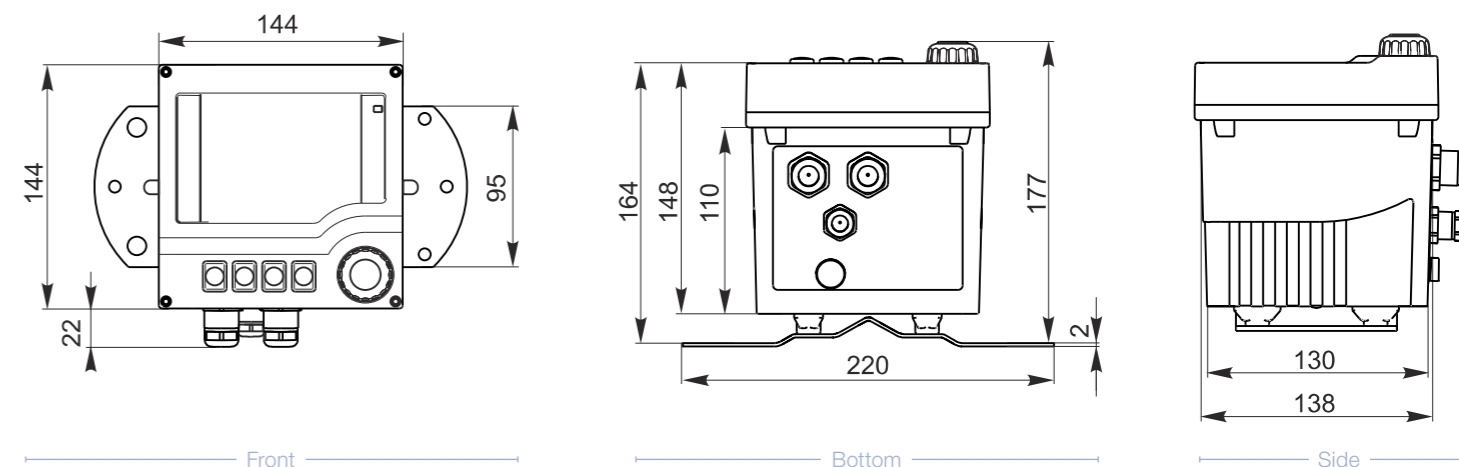

Housings

Different processes have different requirements for sensors to provide an accurate and reliable measurement. Being in contact with the media is the most important one. In order to meet the different requirements, Hamilton has developed various kinds of housings and armatures: static, retractable, pressurizable, pneumatic, manual, weld-in and hygienic sockets.

No matter what type of housing is needed for a pipe or a vessel, on the following pages the right one for each application can be found.

FlexiFit



Specifications

Wetted parts	Stainless Steel 1.4435
O-ring material	EPDM (FDA approved)
O-ring position	22 mm – 55 mm (G 1¼)
Pressure range (relative to ambient)	0 – 6 bar
Temperature range	-10 – 140 °C
Sensor thread	PG 13.5
Sensor a-length	120 mm
Surface finish	R _a < 0.4 µm (N5 electropolished)
ATEX approval	CE 0035 II 1/2 G Ex ia IIC T4/T5/T6

Other designs and materials available on request

The FlexiFit housings are designed for 120 mm sensors in different kinds of industries. A variety of process connections ensure the usability in the chemical industry as well as in hygienic processes. All FlexiFit have EPDM o-rings and the electropolished surface quality (R_a < 0.4 µm) quality is shown on a certificate. They are suitable for autoclavation, CIP and SIP procedures.

Benefits

- ▶ Easy installation and handling
- ▶ Various o-ring positions available
- ▶ ATEX approved
- ▶ Hygienic design

Ordering Information

Type	Process Connection	Ref
FlexiFit Bio	G 1¼	237331-OP
FlexiFit U Bio	G 1¼	237380-OP
FlexiFit TC 150-33	TC 1.5"	237341
FlexiFit VV-0	Varivent®	237344
FlexiFit VV-15	Varivent®	237345

U = Unprotected
TC = Triclamp

Dimensional drawing / FlexiFit

all dimensions in mm

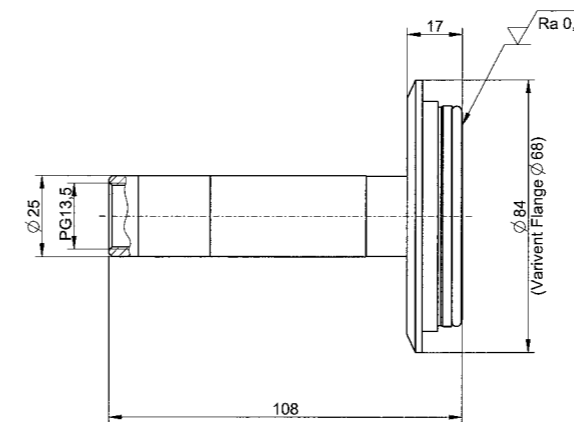

FlexiFit VV-0

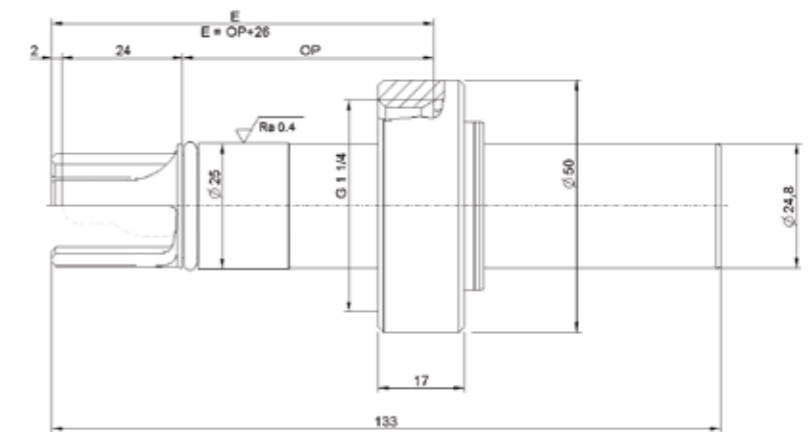

FlexiFit Bio

Accessories



- **Service Kit FlexiFit Bio** Ref 237366
- **Service Kit FFKM** Ref 237319
- **Service Kit FKM** Ref 237219

Safety Socket see page 136



RetractoFit



The RetractoFit is a retractable armature designed for 225 mm sensors in industrial applications. It allows the operator to mount and dismount sensors while the process is running. Safe sensor handling during process is guaranteed because insertion into the vessel without a sensor is impossible so is removal while in the measuring position. It is easy to use and maintain: only one press on the red button is needed to move the sensor into or out of the process. All o-rings can easily be replaced by the operator without special tools. The RetractoFit is available in different versions.

When the housing with an Arc sensor, VisiPro DO (Ex), VisiTrace DO and protective sleeve the aperture (hole) in the protective sleeve must be enlarged or the housing has to be used without the protective sleeve. Wireless adapters on top of Arc sensors can only be used without the protective sleeve.

Benefits

- ▶ Integral safety mechanism
- ▶ Sensor can be withdrawn from the process for cleaning, calibration or replacement
- ▶ Easy maintenance
- ▶ 3.1 material certificate included

Ordering Information

Type	Process Connection	Ref
RetractoFit	G 1¼	237240
RetractoFit PEEK 25	G 1¼	237490



Specifications

Wetted parts	RetractoFit: Stainless Steel 1.4571 RetractoFit PEEK: PEEK (FDA approved)
O-ring material	FKM
O-ring position	RetractoFit: 22.5 mm RetractoFit PEEK: 25 mm
Pressure range (relative to ambient)	0 – 6 bar
Temperature range	-10 – 130 °C
Sensor thread	PG 13.5
Sensor a-length	225 mm
Surface finish	RetractoFit: $R_a < 0.4 \mu\text{m}$ (N5 electropolished)
ATEX approval	RetractoFit: CE 0035 II 1/2 G Ex ia IIC T4/T5/T6 RetractoFit PEEK: CE 0035 II 1/2 G Ex ia IIB T4/T5/T6

Dimensional drawings / RetractoFit

all dimensions in mm

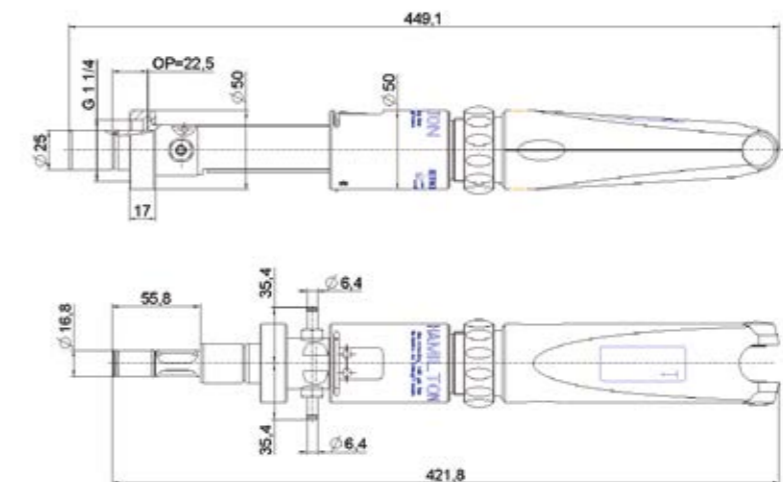

Maintenance position

Measuring position

Accessories



- **Service Kit RetractoFit** Ref 237239
- **FFKM Kit RetractoFit** Ref 237339
- **Insertion tube short** Ref 237255

Safety Socket see page [136](#)

RetractoFit Bio

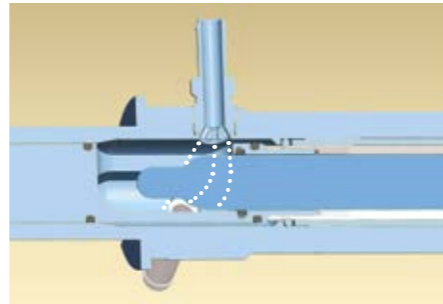

The RetractoFit Bio is a retractable housing designed for 225 mm sensors in hygienic applications in the biotechnology, food & beverage and the pharmaceutical industry. It allows the operator to mount and dismount sensors while the process is running. Safe sensor handling during the process is guaranteed because insertion into a vessel without sensor is impossible so is removal while in the measuring position. It is easy to use and maintain: only one press on the red button is needed to move the sensor into or out of the process. All o-rings can be easily be replaced by the operator without special tools.



“Did you know... that the RetractoFit Bio has a special rinsing chamber with angled connections for cleaning solutions and special inlet construction guarantees an entire cleaning of the chamber through a swirl effect”

Benefits

- ▶ Integral safety mechanism
- ▶ Sensor can be withdrawn from the process for cleaning, calibration or replacement
- ▶ Special hygienic design of cleaning chamber
- ▶ Easy maintenance

Specifications

Wetted parts	Stainless Steel 1.4435
O-ring material	EPDM (FDA approved)
O-ring position	22 mm and 55 mm
Pressure range (relative to ambient)	0 – 6 bar
Temperature range	-10 – 140 °C
Sensor thread	PG 13.5
Sensor a-length	225 mm
Surface finish	R _a < 0.4 µm (N5 electropolished)
ATEX approval	CE 0035 II 1/2 G Ex ia IIC T4/T5/T6

Dimensional drawings / RetractoFit Bio 55

all dimensions in mm

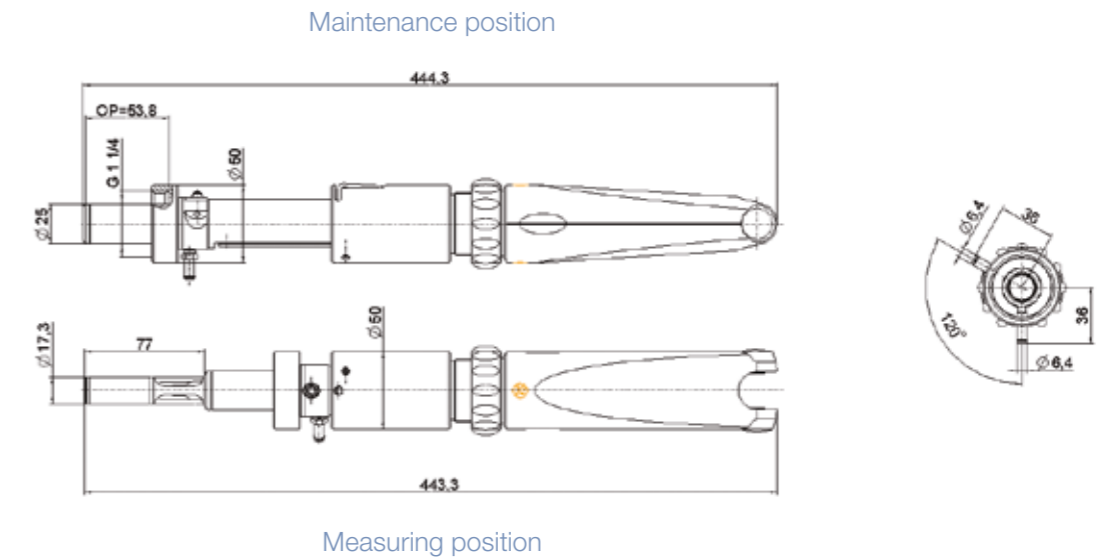

Ordering Information

Type	Process Connection	Ref
RetractoFit Bio 25	G 1/4	237480
RetractoFit Bio 55	G 1/4	237440

Accessories



• **FDA Service Kit** Ref 237338

Safety Socket see page 136



USP
Class VI



Retractable B

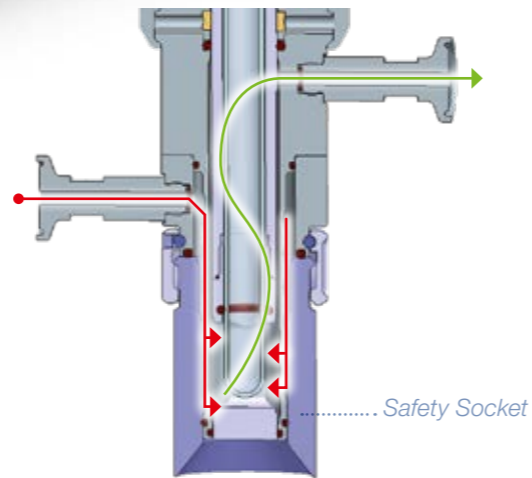

The retractable pneumatic or manual housing Retractable B was designed for sanitary applications in biotechnology, food & beverage and pharmaceutical industry. The compact design with a stroke of only 36 mm keeps wear on seals to a minimum and creates excellent reliability – day and night, all year long. It can be cleaned easily and thoroughly in place, including the space between the socket and rinsing chamber. The Retractable B with its patented HyCIP cleaning principle offers the best available cleaning efficiency for Ingold sockets (G 1¼”).

It is designed for 12 mm sensors and is equipped with several safety features (e.g. no sensor – no insertion, window to check seals for leakage etc.) to provide operator safety. It is available with various process connections that can be used with all vessels used in these branches.

How does the HyCIP process connection work?

In cleaning position, the sensor can be cleaned and sterilized together with all wetted seals. In the HyCIP connection the cleaning solution is directed between armature and socket up to the process seal so the most remote parts of the chamber are rinsed. Thus HyCIP housings are unmatched for their cleaning performance of the sensor and of all relevant seals.

Benefits

- ▶ Extremely compact design
- ▶ Integrated safety concept- no sensor – no insertion
- ▶ Very low maintenance
- ▶ Sterile safety and unique cleaning efficiency with HyCIP

Specifications

Wetted parts	Stainless Steel 1.4404
O-ring material	EPDM (FDA approved) or FKM
O-ring position	25 mm, 50 mm and 55 mm
Pressure range (relative to ambient)	0 – 16 bar (120 °C), 10 bar (140 °C)
Temperature range	-10 – 140 °C
Sensor a-length	225 mm
Surface finish	R _a < 0.8 µm (N6)
ATEX approval	Conform to DIN EN 13463-1

Ordering Information

Retractable Housing: Retractable B (hygienic)

Code	Material (wetted parts)
243240	Retractable B (pneumatic)
243275	Retractable B M (manual)
1	Stainless Steel 1.4404 (material certificate included)
0	special
Code	Sealing Material (wetted sealings)
1	EPDM/FDA USP class VI (elastomer certificate included)
2	FKM
0	special
Code	Sensor
1	225 mm PG 13.5 Gel-filled
0	special
Code	Process Connection
1	Ingold (G 1¼”) o-Ring Position 28 mm
2	Varivent N DN 40-125
3	TriClamp 1,5” (OD Ø 50,5 mm)
4	TriClamp 2” (OD Ø 64 mm)
5	NEUMO BioControl 50
6	DIN 11851 DN50
7	HyCIP for Ingold (G 1¼”) o-Ring Position 25 mm
8	HyCIP for Ingold (G 1¼”) o-Ring Position 50 mm
9	HyCIP for Ingold (G 1¼”) o-Ring Position 55 mm
0	special
Code	Cleaning Connection
1	G ½” thread female
2	G 1¼” thread female
3	¼” NPT female
4	TriClamp ¾”
9	TriClamp ¾” Ø10.3 Sartorius
0	special
Code	Position switch
1	pneumatic / without for manual
0	special
Ref	← Order Code



Retractex BC Steel

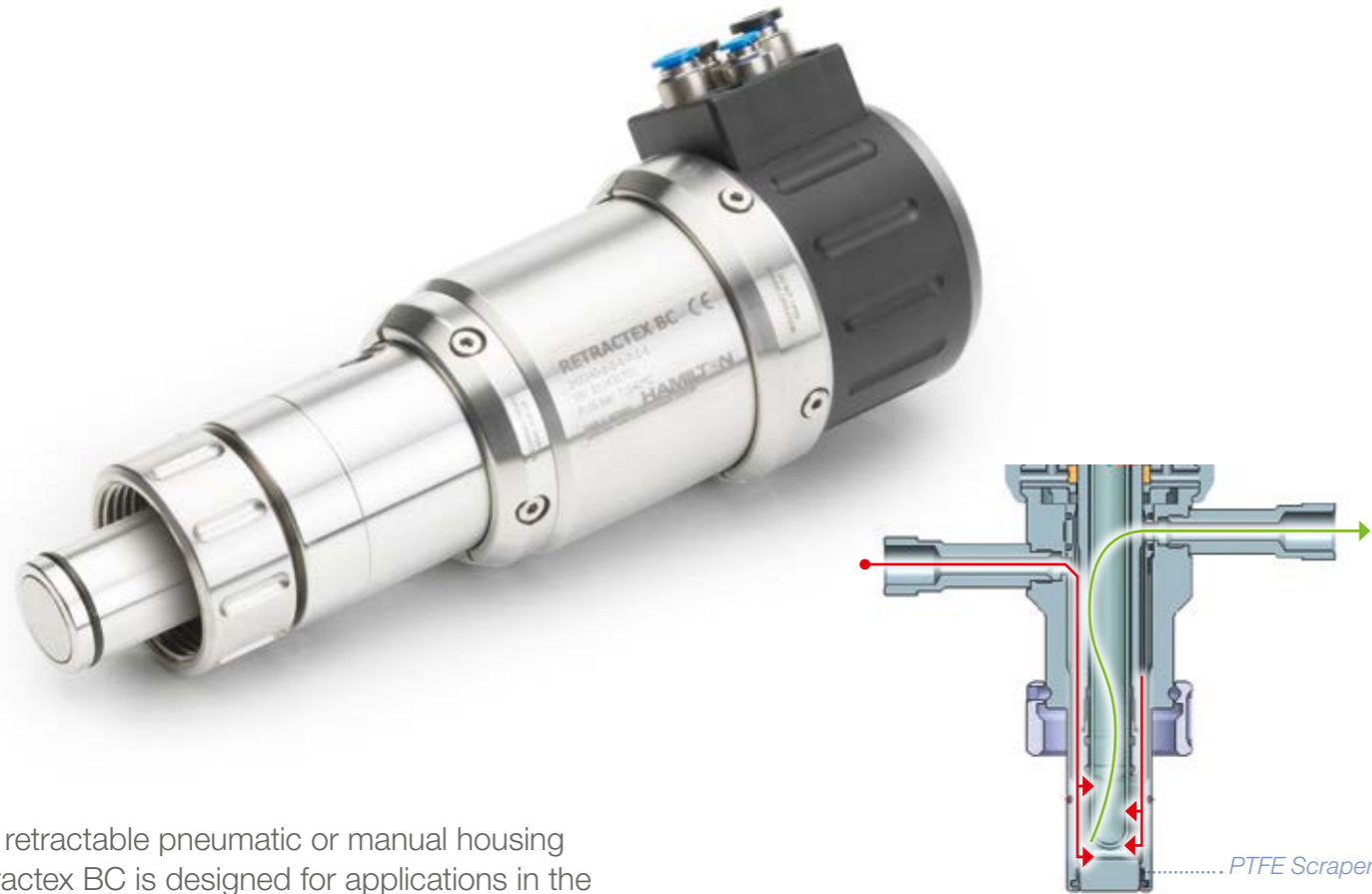

The retractable pneumatic or manual housing Retractex BC is designed for applications in the chemical industry. The compact design with a stroke of only 36 mm keeps wear on seals to a minimum and creates to excellent reliability – day and night, all year long. It can be cleaned easily and thoroughly in place. It is designed for 12 mm sensors and is equipped with several safety features (e.g. no sensor – no insertion, window to check seals for leakage etc.) to provide operator safety. The Retractex BC comes with a G 1/4" process connection and is available with two different o-ring positions.

Cleaning of the Retractex BC?

In cleaning position, the sensor can be cleaned while the process is running. The advantage of the insertion tube is the short way for insertion. A PTFE scraper with o-ring guarantees that dirt stays outside of the armature and does not harm the o-ring.

Benefits

- ▶ Extremely compact design
- ▶ Integrated safety concept- no sensor – no insertion
- ▶ Very low maintenance
- ▶ Sterile safety and unique cleaning efficiency with HyCIP

Specifications

Wetted parts	Stainless Steel 1.4404 or 2.4602
O-ring material	EPDM (FDA approved) or FKM or FFKM
Pressure range (relative to ambient)	0 – 16 bar (120 °C), 10 bar (140 °C)
Temperature range	-10 – 140 °C
Sensor a-length	225 mm
Surface finish	R _a < 0.8 µm (N6)
ATEX approval	Conform to DIN EN 13463-1

Ordering Information

Retractable Housing: Retractex BC Steel

237730	Retractex BC Steel (pneumatic)	
237735	Retractex BC Steel M (manual)	
	Code	Material (wetted parts)
	1	Stainless Steel 1.4404 (Declaration of Quality)
	2	Stainless Steel 2.4602
	0	special
	Code	Sealing Material (wetted sealings)
	1	EPDM/FDA USP VI
	2	FKM
	3	FFKM
	0	special
	Code	Sensor
	1	225 mm PG 13.5 Gel-filled
	0	special
	Code	Process Connection
	1	Ingold (G 1/4") o-Ring Position 28 mm
	2	Ingold (G 1/4") o-Ring Position 50 mm
	0	special
	Code	Cleaning Connection
	1	G 1/8" thread female
	2	G 1/4" thread female
	3	1/4" NPT female
	0	special
	Code	Position switch
	1	pneumatic
	0	special
Ref	← Order Code	



Retractex BC Plastic

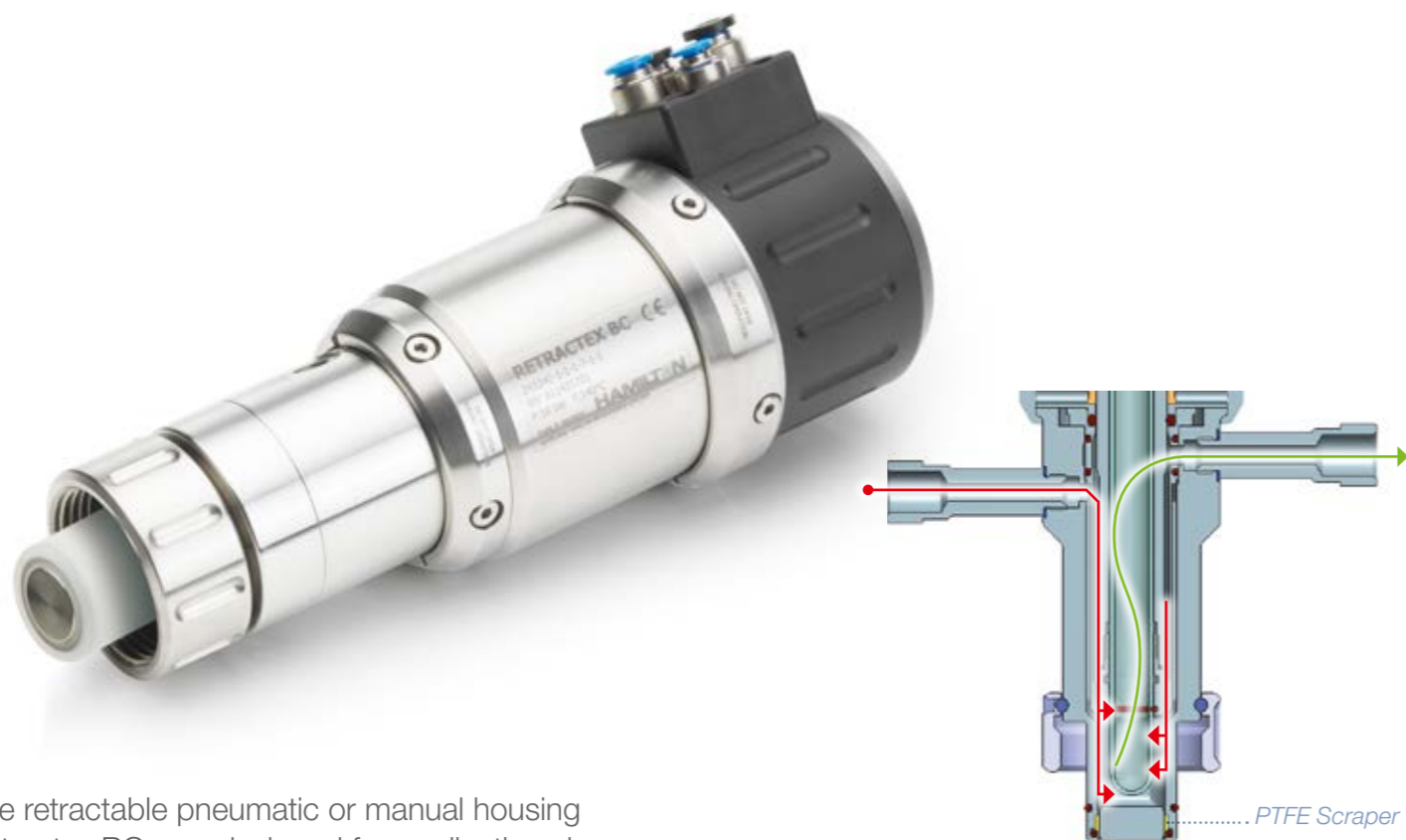

The retractable pneumatic or manual housing Retractex BC was designed for applications in the chemical industry. The compact design with a stroke of only 36 mm keeps wear on seals to a minimum and creates excellent reliability – day and night, all year long. It can be cleaned easily and thoroughly in place. It is designed for 12 mm sensors and is equipped with several safety features (e.g. no sensor – no insertion, window to check seals for leakage etc.) to provide operator safety. The Retractex BC comes with a G 1/4" process connection and is available with two different o-ring positions.

Cleaning of the Retractex BC?

In cleaning position, the sensor can be cleaned while the process is running. The advantage of the insertion tube is the short way for insertion. A PTFE scraper with o-ring guarantees that dirt stays outside of the armature and does not harm the o-ring.

Benefits

- ▶ Extremely compact design
- ▶ Integrated safety concept- no sensor – no insertion
- ▶ Very low maintenance
- ▶ Easy installation of the pneumatic armature with color coded connectors
- ▶ Choice of 3 different plastics

Specifications

Wetted parts	PVDF or PEEK or PP
O-ring material	EPDM (FDA approved), FKM or FFKM
Pressure range (relative to ambient)	0 – 16 bar (120 °C), 10 bar (140 °C)
Temperature range	-10 – 140 °C
Sensor a-length	225 mm
Surface finish	R _a < 0.8 µm (N6)
ATEX approval	Conform to DIN EN 13463-1

Ordering Information

Retractable Housing: Retractex BC Plastic

237740 Retractex BC Plastic (pneumatic)
237745 Retractex BC Plastic M (manual)

Code Material (wetted parts)

1	PP
2	PVDF / Stainless Steel 2.4602
3	PEEK
0	special

Code Sealing Material (wetted sealings)

1	EPDM/FDA USP VI
2	FKM
3	FFKM
0	special

Code Sensor

1	225 mm PG 13.5 Gel-filled
0	special

Code Process Connection

1	Ingold (G 1/4") o-Ring Position 25 mm
0	special

Code Cleaning Connection

1	G 1/8" thread female
2	G 1/4" thread female
3	1/4" NPT female
0	special

Code Position switch

1	pneumatic
0	special

Ref							← Order Code
-----	--	--	--	--	--	--	--------------



USP
Class VI



Retractable C Steel



The retractable pneumatic or manual housing Retractable C was designed for applications in the chemical industry. The compact design with a stroke of only 36 mm keeps wear on seals to a minimum and creates to excellent reliability – day and night, all year long. It can be cleaned easily and thoroughly in place. It is designed for 12 mm sensors and is equipped with several safety features (e.g. no sensor – no insertion, window to check seals for leakage etc.) to provide operator safety. It is available with various process connections that can be used with all vessels used in this branch.

Cleaning of the Retractable C?

In cleaning position, the sensor can be cleaned while the process is running. The advantage of the insertion tube is the short way for insertion. A PTFE scraper with o-ring guarantees that dirt stays outside of the armature and does not harm the o-ring.

“Did you know... that the pneumatic Retractable can be connected to the RetractoControl for even more comfortable handling?”

Benefits

- ▶ Extremely compact design
- ▶ Integrated safety concept- no sensor – no insertion
- ▶ Very low maintenance
- ▶ Easy installation of the pneumatic armature with color coded connectors

Specifications

Wetted parts	Stainless Steel 1.4404 or 2.4602
O-ring material	EPDM (FDA approved) or FKM or FFKM
Pressure range (relative to ambient)	0 – 16 bar (120 °C), 10 bar (140 °C)
Temperature range	-10 – 140 °C
Sensor a-length	225 mm
Surface finish	R _a < 0.8 µm (N6)
ATEX approval	Conform to DIN EN 13463-1

Ordering Information

Retractable C Steel

243200	Retractable C Steel (pneumatic)	
243255	Retractable C Steel M (manual)	
	Code	Material (wetted parts)
	1	Stainless Steel 1.4404 (material certificate included)
	2	Stainless Steel 2.4602 (material certificate included)
	0	special
	Code	Sealing Material (wetted sealings)
	1	EPDM / USP class VI (elastomer certificate included)
	2	FKM
	3	FFKM
	0	special
	Code	Sensor
	1	225 mm PG 13.5 Gel-filled
	0	special
	Code	Process Connection
	1	Flange DN32 PN16
	2	Flange DN40 PN16
	3	Flange DN50 PN16
	4	Flange ANSI 1¼" 150lbs
	5	Flange ANSI 1½" 150lbs
	6	Flange ANSI 2" 150lbs
	7	NPT M 1¼"
	8	TriClamp 2"
	0	special
	Code	Cleaning Connection
	1	G ⅛" thread female
	2	G ¼" thread female
	3	¼" NPT female
	0	special
	Code	Position switch
	1	pneumatic / without for manual
	0	special
Ref	← Order Code	



USP
Class VI



Retractable C Plastic



The retractable pneumatic or manual housing Retractable C was designed for applications in the chemical industry. The compact design with a stroke of only 36 mm keeps wear on seals to a minimum and creates excellent reliability – day and night, all year long. It can be cleaned easily and thoroughly in place. It is designed for 12 mm sensors and is equipped with several safety features (e.g. no sensor – no insertion, window to check seals for leakage etc.) to provide operator safety. It is available with various process connections that can be used with all vessels used in this branch.

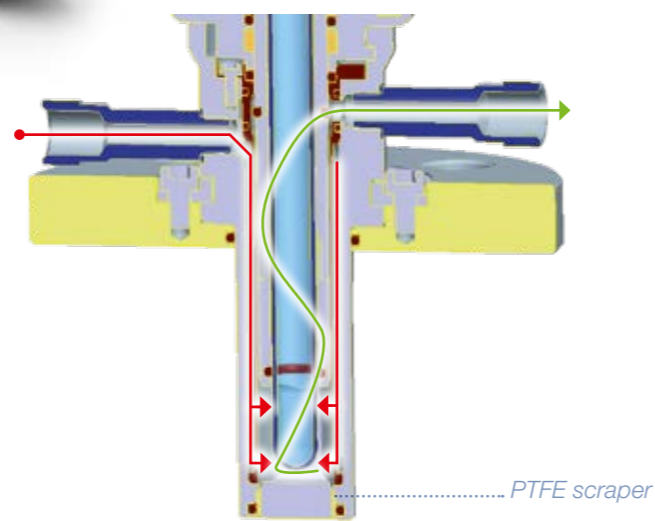

Cleaning of the Retractable C?

In cleaning position, the sensor can be cleaned while the process is running. The advantage of the insertion tube is the short way for insertion. A PTFE scraper with o-ring guarantees that dirt stays outside of the armature and does not harm the o-ring.

Benefits

- ▶ Extremely compact design
- ▶ Integrated safety concept- no sensor – no insertion
- ▶ Very low maintenance
- ▶ Easy installation of the pneumatic armature with color coded connectors
- ▶ Choice of 3 different plastics

Specifications

Wetted parts	PVDF or PEEK or PP
O-ring material	EPDM (FDA approved), FKM or FFKM
Pressure range (relative to ambient)	0 – 16 bar (120 °C), 10 bar (140 °C)
Temperature range	-10 – 140 °C
Sensor a-length	225 mm
Surface finish	R _a < 0.8 μm (N6)
ATEX approval	Conform to DIN EN 13463-1

Ordering Information

Retractable Housing: Retractable C Plastic

243220	Retractable C Plastic (pneumatic)	
243265	Retractable C Plastic M (manual)	
	Code	Material (wetted parts)
	1	PP
	2	PVDF / Stainless Steel 2.4602
	3	PEEK (FDA approval certificate included)
	0	special
	Code	Sealing Material (wetted sealings)
	1	EPDM / FDA USP class VI (elastomer certificate included)
	2	FKM
	3	FFKM
	0	special
	Code	Sensor
	1	225 mm PG 13.5 Gel-filled
	0	special
	Code	Process Connection
	1	Flange DN50
	2	Flange ANSI 2"
	3	NPT M 1 1/4"
	0	special
	Code	Cleaning Connection
	1	G 1/8" thread female
	2	G 1/4" thread female
	3	1/4" NPT female
	0	special
	Code	Position switch
	1	pneumatic / without for manual
	0	special
Ref		← Order Code



Retractex C Steel LT



The retractable pneumatic or manual housing Retractex C was designed for applications in the chemical industry. The compact design with a stroke of only 36 mm with an insertion depth up to 207 mm keeps wear on seals to a minimum and creates excellent reliability – day and night, all year long. It can be cleaned easily and thoroughly in place. It is designed for 12 mm sensors and is equipped with several safety features (e.g. no sensor – no insertion, window to check seals for leakage etc.) to provide operator safety. It is available with various process connections that can be used with all vessels used in this branch.

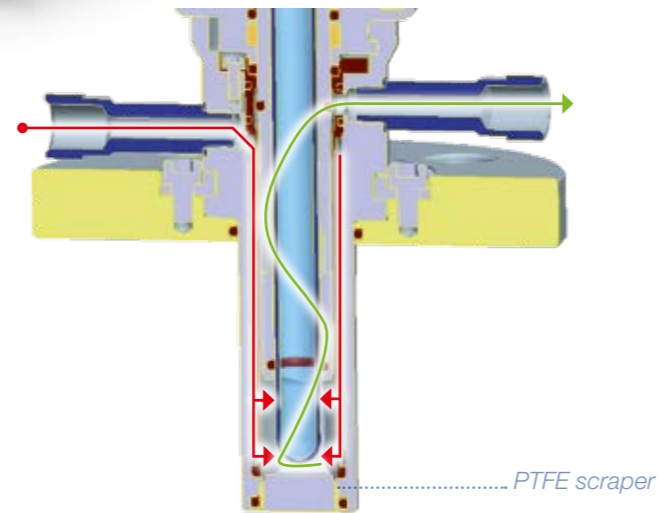

Cleaning of the Retractex C?

In cleaning position, the sensor can be cleaned while the process is running. The advantage of the insertion tube is the short way for insertion. A PTFE scraper with o-ring guarantees that dirt stays outside of the armature and does not harm the o-ring.

Benefits

- ▶ Extremely compact design (only 36 mm travel of insertion tube with an insertion depth of 207 mm)
- ▶ Integrated safety concept- no sensor – no insertion
- ▶ Very low maintenance
- ▶ Easy installation of the pneumatic armature with color coded connectors

Specifications

Wetted parts	Stainless steel 1.4404 or 2.4602
O-ring material	EPDM (FDA approved) or FKM or FFKM
Pressure range (relative to ambient)	0 – 16 bar (120 °C), 10 bar (140 °C)
Temperature range	-10 – 140 °C
Sensor a-length	325 mm
Surface finish	R _a < 0.8 μm (N6)
ATEX approval	Conform to DIN EN 13463-1

Ordering Information

Retractable Housing: Retractex C Steel LT

Code	Material (wetted parts)
243210	Retractex C Steel LT (pneumatic)
243260	Retractex C Steel LT M (manual)
1	Stainless Steel 1.4404 (material certificate included)
2	Stainless Steel 2.4602 (material certificate included)
0	special
Code	Sealing Material (wetted sealings)
1	EPDM / FDA USP class VI (elastomer certificate included)
2	FKM
3	FFKM
0	special
Code	Sensor
1	325mm PG 13.5 Gel-filled
0	special
Code	Process Connection
1	Flange DN40
2	Flange DN50
3	Flange ANSI 1½"
4	Flange ANSI 2"
0	special
Code	Cleaning Connection
1	G ⅜" thread female
2	G ¼" thread female
3	¼" NPT female
0	special
Code	Position switch
1	pneumatic / without for manual
0	special
Ref	← Order Code



Retractable C Plastic LT



The retractable pneumatic or manual housing Retractable C was designed for applications in the chemical industry. The compact design with a stroke of only 36 mm with an insertion depth up to 207 mm keeps wear on seals to a minimum and creates excellent reliability - day and night, all year long. It can be cleaned easily and thoroughly in place. It is designed for 12 mm sensors and is equipped with several safety features (e.g. no sensor – no insertion, window to check seals for leakage etc.) to provide operator safety. It is available with various process connections that can be used with all vessels used in this branch.

Cleaning of the Retractable C?

In cleaning position, the sensor can be cleaned while the process is running. The advantage of the insertion tube is the short way for insertion. A PTFE scraper with o-ring guarantees that dirt stays outside of the armature and does not harm the o-ring.

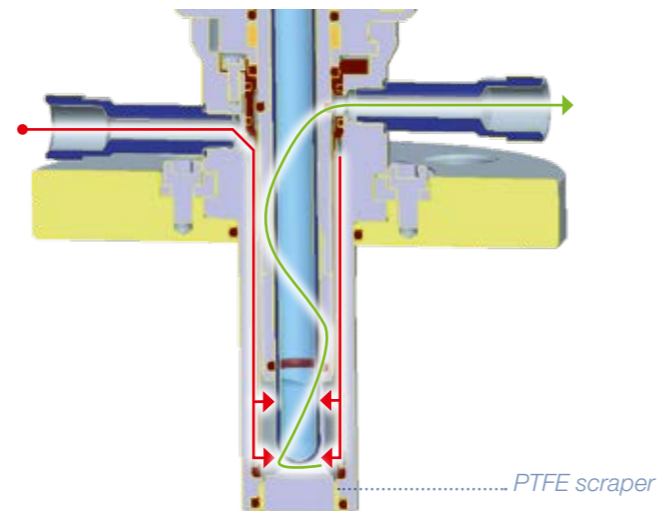

Benefits

- ▶ Extremely compact design (only 36 mm travel of insertion tube with an insertion depth of 207 mm)
- ▶ Integrated safety concept- no sensor – no insertion
- ▶ Very low maintenance
- ▶ Easy installation of the pneumatic armature with color coded connectors

Specifications

Wetted parts	PVDF or PEEK
O-ring material	EPDM (FDA approved) or FKM or FFKM
Pressure range (relative to ambient)	0 – 16 bar (120 °C), 10 bar (140 °C)
Temperature range	-10 – 140 °C
Sensor a-length	325 mm
Surface finish	R _a < 0.8 μm (N6)
ATEX approval	Conform to DIN EN 13463-1

Ordering Information

Retractable Housing: Retractable C Plastic LT

Code	Material (wetted parts)
243230	Retractable C Plastic LT (pneumatic)
243270	Retractable C Plastic LT M (manual)
1	PVDF / Stainless Steel 2.4602
2	PEEK (FDA approval certificate included)
0	special
Code	Sealing Material (wetted sealings)
1	EPDM / FDA USP class VI (elastomer certificate included)
2	FKM
3	FFKM
0	special
Code	Sensor
1	325mm PG 13.5 Gel-filled
0	special
Code	Process Connection
1	Flange DN50
2	Flange ANSI 2"
0	special
Code	Cleaning Connection
1	G 1/8" thread female
2	G 1/4" thread female
0	special
Code	Position switch
1	pneumatic / without for manual
0	special
Ref	← Order Code



MasterFit



Specifications

Wetted parts	Stainless Steel 1.4435
O-ring material	EPDM (FDA approved)
O-ring position	22 mm – 55 mm
Pressure range (relative to ambient)	0 – 6 bar
Temperature range	-10 – 130 °C
Sensor a-length	120, 150, 200 mm
Surface finish	R _a < 0.8 μm (N6)
ATEX approval	CE 0035 II 1/2 G Ex ia IIC T4/T5/T6

The MasterFit is a housing for pressurizable pH sensors like the ChemoTrode types. The pressurization ensures a constant outflow of electrolyte. This helps to prevent clogging of the diaphragm and poisoning of the electrolyte. The MasterFit can be used in a huge variety of applications mainly in the chemical industry.

The pressure inside the MasterFit can be controlled via a built-in manometer. Furthermore the liquid level of the electrode can be controlled through the coated glass body of the armature at any time.

Benefits

- ▶ Sealing feature prevents loss of pressure caused by soiling
- ▶ Pressure reduction on disassembly
- ▶ Various o-ring positions available
- ▶ Easy maintenance

Ordering Information

Type	Process Connection	Ref
MasterFit 120	G 1¼	237200-OP
MasterFit 150	G 1¼	237225-OP
MasterFit 250	G 1¼	237245-30

Dimensional drawings / MasterFit 120

all dimensions in mm

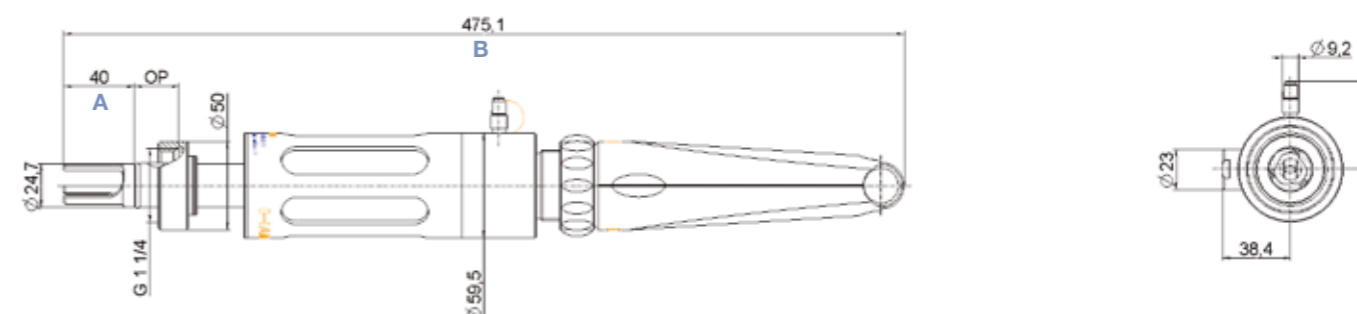

Type	A (armature insertion depth)	B (total length)
MasterFit 120	40 mm	475 mm
MasterFit 150	70 mm	505 mm
MasterFit 250	170 mm	605 mm

Accessories



- **Pressure Adapter** Ref 237252
- **Service Kit for MasterFit** Ref 237229
- **FFKM Kit for MasterFit** Ref 237319

- **Flange Adapter for MasterFit*** Ref 237810

Safety Socket see page 136

* The Flange Adapter is used with a MasterFit 120 and a sensor with a shaft length of 150 mm



USP
Class VI



RetractoMaster



Specifications

Wetted parts	Stainless Steel 1.4571
O-ring material	FKM
O-ring position	22.5 mm
Pressure range (relative to ambient)	0 – 6 bar
Temperature range	-10 – 130 °C
Sensor a-length	250 mm
Surface finish	R _a < 0.4 μm (N5)
ATEX approval	Conform to DIN EN 13463-1

The RetractoMaster is a retractable housing for pressurizable sensors like the ChemoTrode. The pressurization ensures a constant outflow of electrolyte. This helps to prevent clogging of the diaphragm and poisoning of the electrolyte. It allows the operator to mount and dismount the sensors while the process is running. The pressure inside the RetrctoMaster can be controlled via a built-in manometer. Only one press on the red button is needed to move the sensor into or out of the process. Safe sensor handling during process is guaranteed because insertion into a vessel without the sensor is impossible so is removal while in measuring position. O-rings can easily be replaced without special tools. Furthermore the liquid level of the electrode can be controlled through the coated glass body of the armature at any time. The RetractoMaster can be used in a huge variety of applications mainly in the chemical industry.

Benefits

- ▶ Sensor can be withdrawn from the process for cleaning, calibration or replacement
- ▶ Easy maintenance
- ▶ Long life time of the sensor due to pressurization of the sensor and the possibility to remove it while the process is running.
- ▶ 3.1 certificate included

Ordering Information

Type	Process Connection	Ref
RetractoMaster	G 1¼	237250

Dimensional drawings

all dimensions in mm

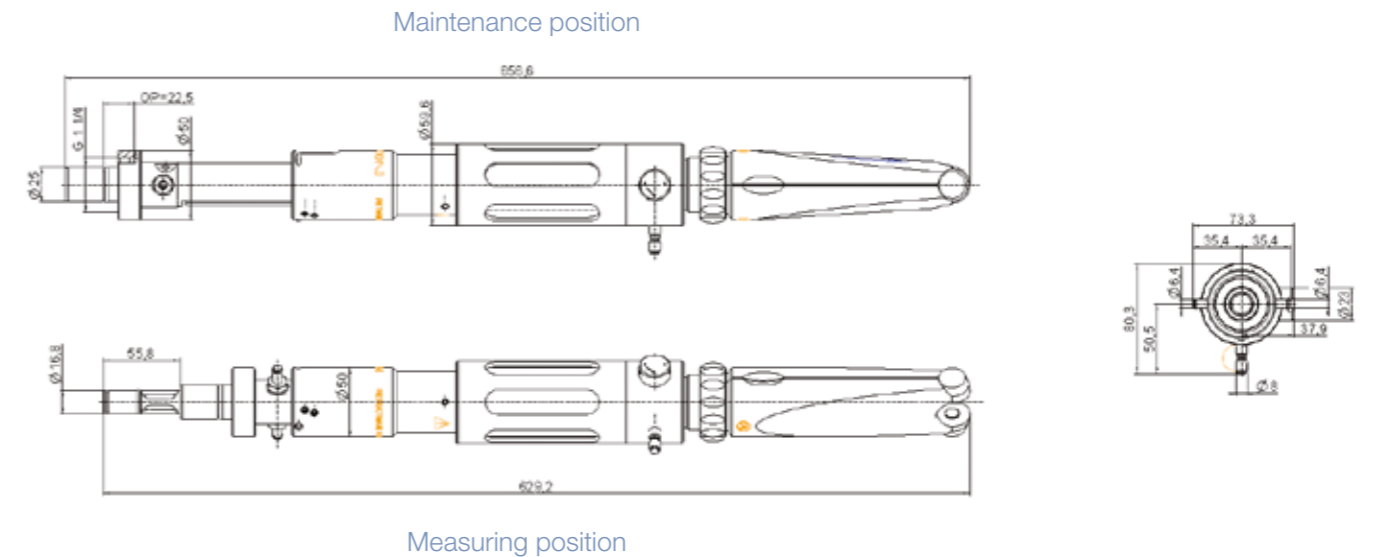

Accessories



- **Pressure Adapter** Ref 237252

Safety Socket see page 136



RetractoControl Plus

Specifications

Ingress protection rating	IP 54
Power	24V DC 30 VA
Air pressure	4 – 6 bar



Dimensional drawings

all dimensions in mm

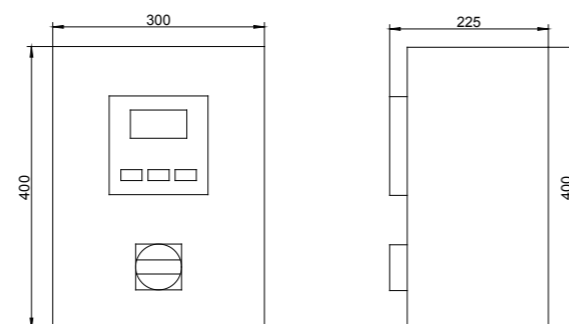

The RetractoControl is a control unit for a pneumatical Retractex used to clean a sensor automatically. The full power of the automatic cleaning system can be achieved with an Arc sensor because it can be built-in pre-calibrated. Analog sensors in combination with a transmitter can be used as well. The measurement and cleaning cycles can be programmed very easily according to the needs of the process. Thanks to automatically controlled cleanings the life time of the sensor can be extended and manpower can be saved.

Connection Plan with Arc Sensor

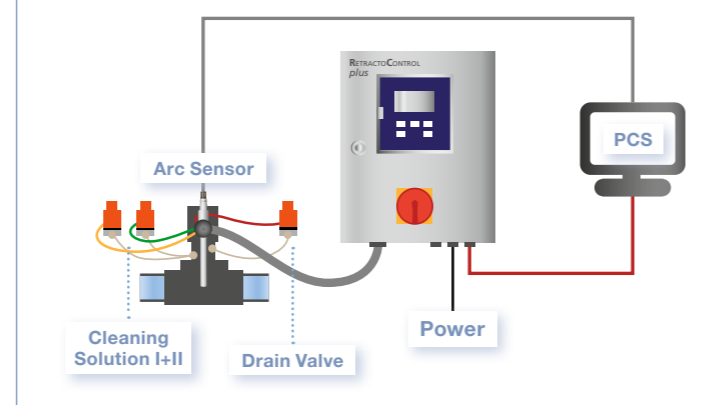

Connection Plan with Analog Sensor

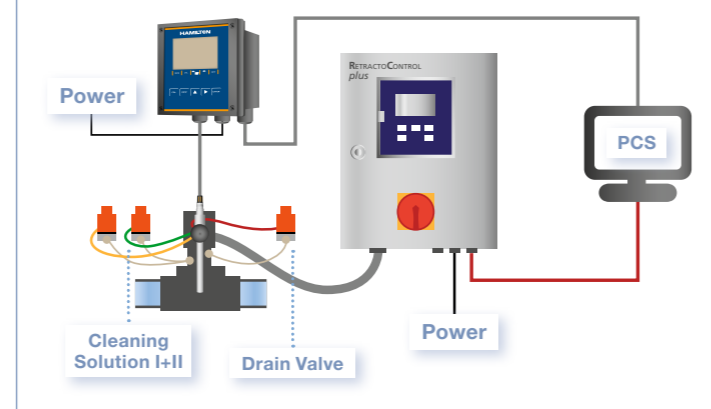

Benefits

- ▶ Scheduled and unattended maintenance
- ▶ Easy interaction with process control system
- ▶ Menu based user interaction
- ▶ Manpower can be saved



Ordering Information

Automatic Control Unit for Retractable

242216	RetractoControl Plus	
	Code	Housing
	1	Plastic housing
	2	Stainless Steel housing
	3	special
	Code	Cleaning
	1	for one cleaning solution with drain port
	2	for two cleaning solutions with drain port
	3	special
	Code	Connecting hose
	1	without
	2	3 m length
	3	5 m length
	4	10 m length
	5	special
	Code	Fastener
	1	without
	2	Fastening angle Retractex
	3	special
242216 -		← Order Code

Accessories



- Wall Mounting Set (for plastic housing) Ref 242214
- Wall Mounting Set (for stainless steel housing) Ref 242212
- Post Mounting Set (for plastic and stainless steel housing) Ref 242213
- Cleaning valve set PVDF/FKM with 2 membrane-valves for one cleaning solution and one drain; connectors, PTFE-tubing and mounting brackets included Ref 242210
- Cleaning valve set PVDF/FKM with 3 membrane-valves for two cleaning solution and one drain; connectors, PTFE-tubing and mounting brackets included Ref 242211

Safety Socket



The Safety Sockets are hygienic weld-in sockets suitable for hygienic armatures like the FlexiFit Bio. They are available for 3 different o-ring positions to cover different standards. Furthermore you can choose between two kinds of stainless steel and two different angles.

The Safety Socket narrows at the o-ring positions and it seals only if the o-ring of the armature is exactly at the right place. If the process is under pressure, a dripping process medium can be a strong hint that the armature should not be loosened entirely. Therefore the Safety Socket is suited for a wide variety of applications and installations.

Benefits

- ▶ Safety design, leakage before total release of the armature
- ▶ Hygienic surface finish
- ▶ 3 different o-ring positions and two different stainless steels available

O-ring sealing position

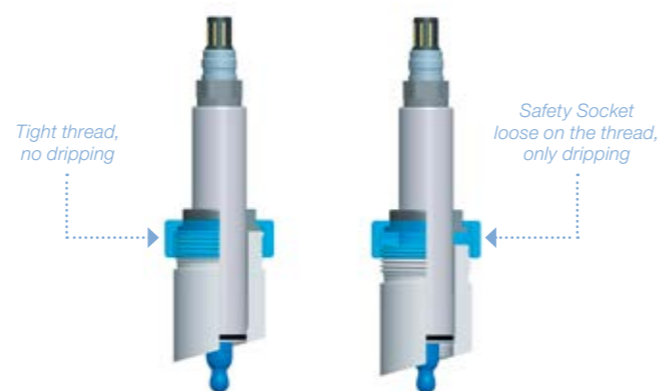

Specifications

Wetted parts	Stainless Steel 1.4435, 1.4404 or 1.4571
O-ring material for blind plug	EPDM (FDA approved)
Pressure range (relative to ambient)	0 – 50 bar
Temperature range	-30 – 160 °C
Process connection	G 1¼
Surface finish	R _a < 0.8 µm (N6)
ATEX approval	Conform to DIN EN 13463-1

Ordering Information

Type	Steel	Angle	OP	Ref
Safety Socket	1.4404	15	25	242570
Safety Socket	1.4404	15	50	242571
Safety Socket	1.4404	15	55	242572
Safety Socket	1.4404	0	25	242573
Safety Socket	1.4404	0	50	242574
Safety Socket	1.4404	0	55	242575
Safety Socket	1.4435	15	25	242576
Safety Socket	1.4435	15	50	242577
Safety Socket	1.4435	15	55	242578
Safety Socket	1.4435	0	25	242579
Safety Socket	1.4435	0	50	242580
Safety Socket	1.4435	0	55	242581
Weld in socket without safety feature	1.4571	15	25	237202

Dimensional drawings

all dimensions in mm

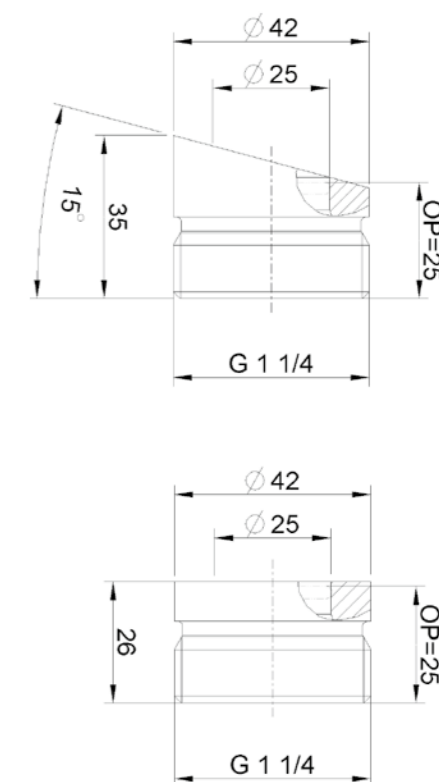

Accessories



- Blind plug 1.4404-25 Ref 242560
- Blind plug 1.4404-50 Ref 242562
- Blind plug 1.4404-55 Ref 242564

- Blind plug 1.4435-25 Ref 242565
- Blind plug 1.4435-50 Ref 242567
- Blind plug 1.4435-55 Ref 242569
- Blind Plug 1.4571-25 Ref 237230

USP
Class VI

FDA

CE



Hygienic Socket



The Hygienic Socket with its space saving design and simple sterilization is ideal to weld in fermenters or small pipes. The advantages are numerous for many other applications in tanks or pipes for water treatment and in the pharmaceutical and chemical industries.

It is designed for 120 mm sensors and developed for easy installation and maintenance, improve the cleaning process and increase safety. Two "Live Guard" openings provide an indication of sealing failures. The sensor insertion depth can be varied for DO sensors by using the Hamilton DO Adapter.

Benefits

- ▶ Hygienic design because complete sensor installation with only one wetted o-ring
- ▶ Space saving
- ▶ Cost saving: Socket and Housing all in one
- ▶ Low maintenance and easy replacement of o-ring

Example for Installation

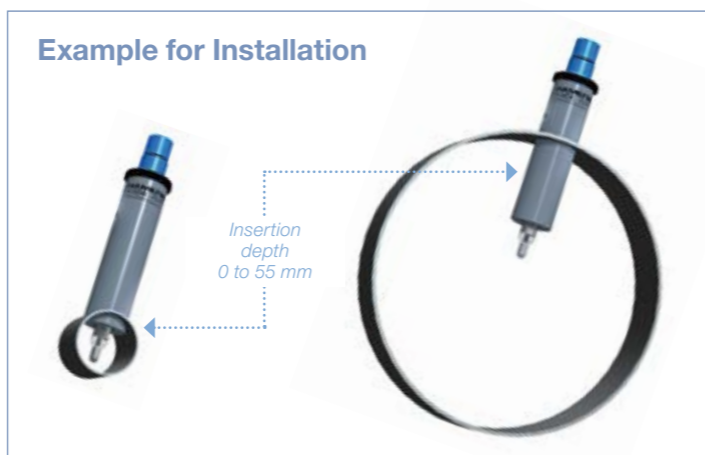

Specifications

Wetted parts	Stainless Steel 1.4435 or 1.4404 or 1.4571 or 2.4602
O-ring material	EPDM (FDA approved)
Pressure range (relative to ambient)	0 – 16 bar
Temperature range	-10 – 140 °C
Sensor thread	PG 13,5
Sensor a-length	120 mm
Surface finish	R _a < 0.4 μm (N5)
ATEX approval	Conform to DIN EN 13463-1

Dimensional drawings

all dimensions in mm

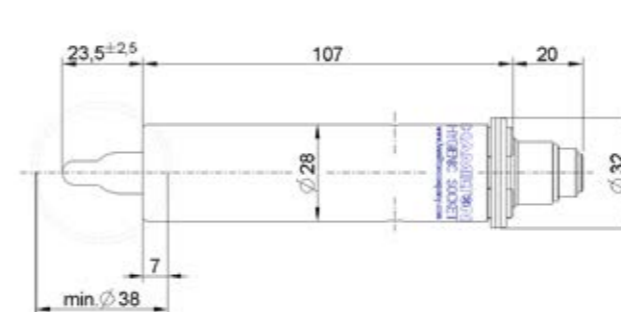

Hygienic socket with a pH sensor

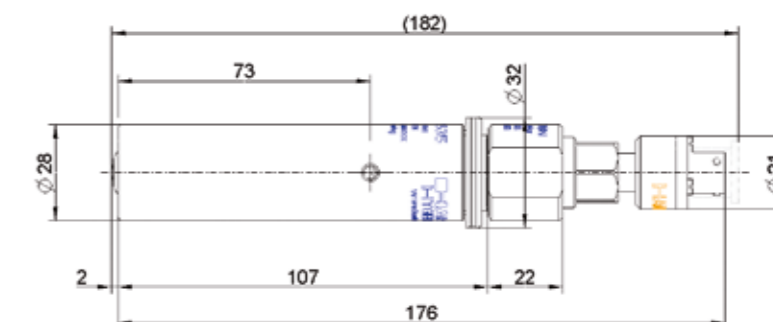

Hygienic socket with DO adapter and oxygen sensor

Ordering Information

Type	Ref
Hygienic Socket 1.4404	242535
Hygienic Socket 1.4435	242545
Hygienic Socket 1.4571	242548
Hygienic Socket 2.4602	242550

Accessories



- Hygienic Socket DO Adapter Ref 242538
- Replacment Kit Seal Pusher Ref 242532
- O-ring set EPDM Ref 242595
- Sensor Dummy Ref

- O-ring set FKM Ref 242596
- O-ring set Silicone Ref 242597
- O-ring set FFKM Ref 242598



USP
Class VI



FlowCell/XL



Hamilton Flow-Through Cells are designed for measuring one or two parameters at a time. Possible combinations are pH/DO and pH/Conductivity. The measurement is done in bypasses when inline measurement is not possible due to small pipe dimensions. Application fields are biotechnology, water treatment and power plants, where reliable measurements have to be carried out in ion-weak media. There are two different sizes of the flow cells available.

Dimensional drawings / 242590 all dimensions in mm

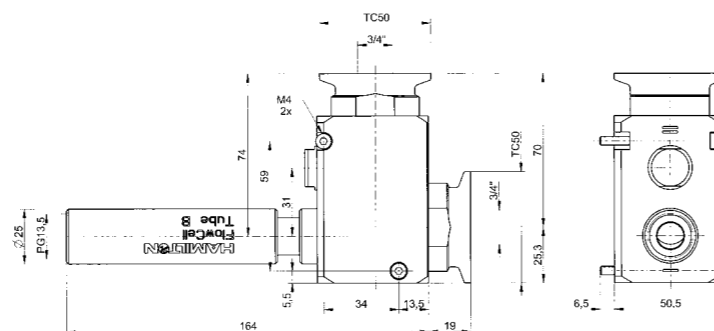

Specifications

Wetted parts	Stainless Steel 1.4435, PEEK
O-ring material for blind plug	EPDM (FDA approved)
Pressure range (relative to ambient)	0 – 16 bar
Temperature range	-10 – 140 °C
Sensor thread	PG 13.5
Sensor a-length	120 mm
Process connection	TC 25, TC 50, Swagelok
ATEX approval	Conform to DIN EN 13463-1

Benefits

- ▶ Flexible design for one or two measuring points
- ▶ PEEK insert of high chemical resistance
- ▶ Low dead volume
- ▶ Self draining
- ▶ Internal aseptic clamp pipe connection

USP
Class VI

FDA

CE



Ordering Information

Flow Cell

242585

Code	Measuring position
1	only pH
2	only Conductivity or Oxygen
3	pH and Conductivity or Oxygen
4	Conductivity and Oxygen
0	special
Code	Pipe Connection
1	TC25 ¼"
2	TC25 ⅜"
3	TC25 ½"
4	Swagelok 6 mm
5	Swagelok 10 mm *)
6	Swagelok ¼"
7	Swagelok ⅜" *)
8	Swagelok ½" *)
0	special
Code	o-ring material
1	EPDM
2	FFKM (two measuring positions)
3	FFKM (one measuring position)
0	special

242585 -

← Order Code

Flow Cell XL

242590

Code	Measuring position
1	only pH
2	only Conductivity or Oxygen
3	pH and Conductivity or Oxygen
4	Conductivity and Oxygen
0	special
Code	Pipe Connection
1	TC50 ¾"
2	TC50 1"
3	TC50 1.5" *)
0	special
Code	o-ring material
1	EPDM
2	FFKM (two measuring positions)
3	FFKM (one measuring position)
0	special

242590 -

← Order Code

*) not self draining

Accessories



- O-ring kit Flow Cell TC25 Ref 237387
- O-ring kit Flow Cell TC50 Ref 237390
- Sensor Dummy 96 mm Ref 242540 117 mm Ref 242563

FlexiFlow SL 10

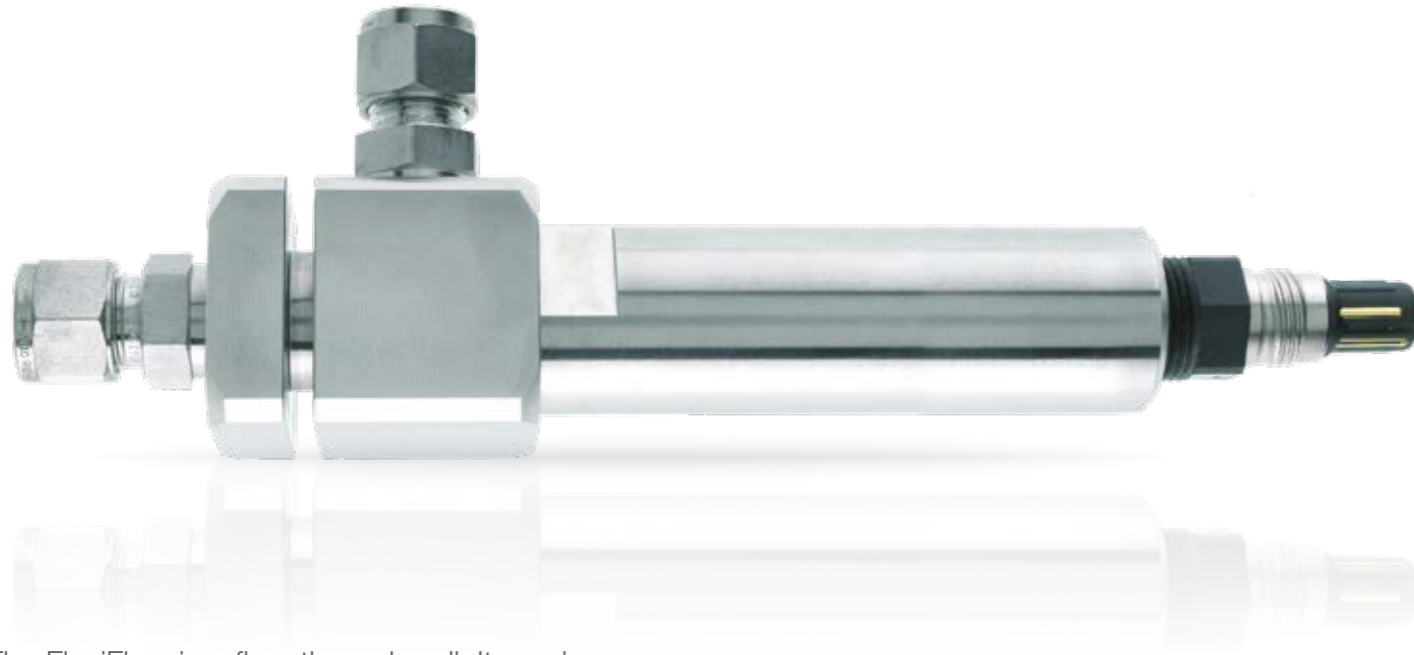

The FlexiFlow is a flow-through cell. It can be used in all cases where pH or oxygen must be reliably measured in ion-weak media including coolant piping in power generating stations.

The sample is fed into the cell from the bottom at a low flow speed, and out of the cell again at the side. A groove cut into the FlexiFlow allows it to easily be attached anywhere with commercially available screws.

Benefits

- ▶ Compact design
- ▶ Easy to attach to a plate
- ▶ For use in small pipes where sensors cannot be inserted directly
- ▶ Self draining

USP
Class VI

FDA

CE



Specifications

Wetted parts	Stainless Steel 1.4435
O-ring material	EPDM (FDA approved)
Pressure range (relative to ambient)	0 – 16 bar
Temperature range	-10 – 130 °C
Sensor thread	PG 13,5
Sensor a-length	120 mm
Process connection	Swagelok 10 mm
ATEX approval	Conform to DIN EN 13463-1

Dimensional drawings

all dimensions in mm

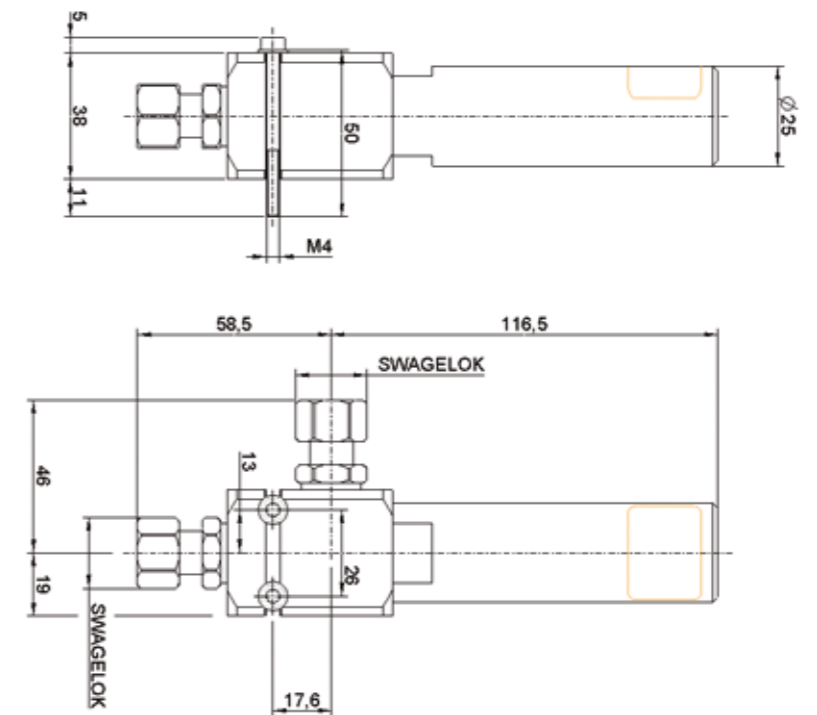

Ordering Information

Type	Ref
FlexiFlow SL 10	237340

Sensor Comparison

pH or ORP sensor

	pH glass type	Nominal measurement range	Recomm. measurement range	Reference system	Reference electrolyte	Diaphragm type	Recomm. min. conductivity (μS/cm)	Nominal temperature range (°C)	Recomm. temperature range (°C)	Nominal pressure max. (bar)	Upside down Installation	Comments
ChemoTrode	PHI	0 - 14	0 - 13	Everef-F	3M KCl-LR	HP ceramic	20	0 - 130	5 - 130	6	No	
ChemoTrode Bridge	PHI	0 - 14	0 - 13	Everef-F	Skylyte	HP ceramic	20	0 - 130	5 - 130	6	No	
ChemoTrode P PHI	PHI	0 - 14	0 - 13	Everef-F	Protelyt	HP ceramic	20	0 - 130	5 - 130	6	No	
FermoTrode	PHI	0 - 14	0 - 13	Everef-F	Skylyte	Coatramic	20	0 - 130	5 - 130	4	No	
EasyControl	HF	0 - 14	0 - 13	Ag/AgCl	Viscous 3M KCl	Ceramic	20	0 - 60	0 - 60	2	No	
InchTrode N100F	HF	0 - 14	2 - 12	Everef-L	Polisolve	Single Pore ring	5	-10 - 130	5 - 100	6	No	
InchTrode N75F	HF	0 - 14	2 - 12	Everef-L	Polisolve	Single Pore ring	5	-10 - 130	5 - 100	6	No	
InchTrode N75FC10	HF	0 - 14	2 - 12	Everef-L	Polisolve	Single Pore ring	5	-10 - 130	5 - 100	6	No	
InchTrode N75P	PHI	0 - 14	2 - 12	Everef-L	Polisolve	Single Pore ring	5	0 - 130	5 - 100	6	No	
InchTrode N75PC10	PHI	0 - 14	2 - 12	Everef-L	Polisolve	Single Pore ring	5	0 - 130	5 - 100	6	No	
IonoTrode	F	0 - 14	0 - 13	Everef	3M KCl	Sleeve	0.2	-10 - 40	-10 - 40	0.5	No	
LIQ-Glass PG	F	1 - 12	1 - 12	Everef	3M KCl-LR	Ceramic	2	-5 - 60	-5 - 60	2	No	
MecoTrode	H	0 - 14	0 - 14	Everef	Viscous 3M KCl	HP ceramic	50	0 - 130	0 - 130	6	No	0 to 16 bar at 25 °C, 0 to 6 bar at 130 °C
Polilyte Pro	HF	0 - 14	2 - 12	Everef-B	Polisolve	Single Pore	5	-10 - 60	-5 - 60	6	only VP	
Polyplast Pro	V	0 - 14	2 - 12	Ag/AgCl	Polisolve	Single Pore	50	-10 - 40	0 - 40	6	No	
Polilyte Plus XP	H	0 - 14	2 - 12	Everef-L	Polisolve Plus	Single Pore	5	0 - 130	0 - 130	16	only VP	0 to 50 bar (60 °C), 0 to 20 bar (100 °C), 0 to 16 bar (130 °C)
pH families												
Polilyte Plus H	H	0 - 14	2 - 12	Everef-L	Polisolve Plus	Single Pore	5	0 - 130	0 - 130	10	only VP	Predecessor: Polilyte Plus, Polilyte HT
Polilyte Plus HB	HB	0 - 14	2 - 12	Everef-L	Polisolve Plus	Single Pore	5	0 - 130	0 - 130	10	only VP	
Polilyte Plus HF	HF	0 - 14	2 - 12	Everef-L	Polisolve Plus	Single Pore	5	-10 - 100	-10 - 100	16	only VP	Predecessor: ClaryTrode
Polilyte Plus PHI	PHI	0 - 14	2 - 12	Everef-L	Polisolve Plus	Single Pore	5	0 - 130	5 - 130	10	only VP	Predecessor: Polyclave
EasyFerm Plus PHI	PHI	0 - 14	2 - 12	Everef-F	Phermyte	HP Coatramic	100	0 - 140	5 - 140	6	No	
EasyFerm Plus HB	HB	0 - 14	2 - 12	Everef-F	Phermyte	HP Coatramic	100	0 - 140	5 - 140	6	No	
EasyFerm Bio PHI	PHI	0 - 14	2 - 13	Everef-F	Foodlyte	HP Coatramic	100	0 - 140	0 - 140	6	No	
EasyFerm Bio HB	HB	0 - 14	2 - 13	Everef-F	Foodlyte	HP Coatramic	100	0 - 140	0 - 140	6	No	
ORP Sensors												
ChemoTrode ORP	Platinum ring	± 2000 mV	± 2000 mV	Everef-F	3M KCl-LR	HP ceramic	20	0 - 130	0 - 130	6	No	
EasyControl ORP	Platinum wire	± 2000 mV	± 2000 mV	Ag/AgCl	Gel	Ceramic	20	0 - 60	0 - 60	2	No	
OxyTrode Pt	Platinum wire	± 2000 mV	± 2000 mV	Everef	Viscous 3M KCl	HP ceramic	50	0 - 130	0 - 130	6	No	
Polilyte RX	Platinum wire	± 2000 mV	± 2000 mV	Everef-B	Polisolve	Single Pore	5	-10 - 60	-10 - 60	6	No	
Polyplast Pro RX	Platinum wire	± 2000 mV	± 2000 mV	Ag/AgCl	Polisolve	Single Pore	50	-10 - 40	-10 - 40	6	No	
EasyFerm Plus ORP	Platinum wire	± 2000 mV	± 2000 mV	Everef-F	Phermyte	HP Coatramic	100	0 - 140	5 - 140	6	No	Arc: ± 1500 mV
Polilyte Plus ORP	Platinum ring	± 2000 mV	± 2000 mV	Everef-L	Polisolve Plus	Single Pore	5	0 - 130	0 - 130	10	only VP	Arc: ± 1500 mV, 0 to 16 bar at 100 °C, 0 to 3 bar at 140 °C



DO sensor

	Measurement principle	Nominal measurement range (DO)	Nominal temperature range	Measurement temperature range	Nominal pressure max. (bar)	Compatible caps / membranes
VisiFerm DO	Optical	4 ppb – 25 ppm	-10 – 140 °C	-10 – 85 °C	12	H0, H2
VisiPro DO	Optical	4 ppb – 25 ppm	-10 – 140 °C	-10 – 85 °C	12	H0, H2
VisiTrace DO	Optical	1 ppb – 2 ppm	-10 – 140 °C	-10 – 85 °C	12	L0
OxyFerm FDA	Amperometric	10 ppb – 40 ppm	0 – 130 °C	0 – 130 °C	4	FDA, CIP, standard
OxyGold B	Amperometric	8 ppb – 40 ppm	0 – 100 °C	0 – 100 °C	12	OxyGold
OxyGold G	Amperometric	1 ppb – 40 ppm	0 – 130 °C	0 – 130 °C	12	OxyGold
Oxysens	Amperometric	40 ppb – 40 ppm	0 – 60 °C	0 – 60 °C	4	none

Conductivity sensor

	Measurement principle	Nominal measurement range	Nominal temperature range	Cell constant	Nominal pressure max. (bar)	Electrodes materials available
Conducell 4UxF	4 pole contacting	1 µS/cm – 300 mS/cm	-20 – 150 °C	0.36/cm	20 (135 °C)	Stainless steel 1.4435, Titanium, Hastelloy C 2.4602, Platinum
Conducell 4US	4 pole contacting	0.1 µS/cm – 500 mS/cm	-20 – 135 °C	0.147/cm	6	Stainless steel 1.4435
Conducell UPW	2 pole contacting	0.01 – 1500 µS/cm	0 – 130 °C	< 0.1/cm	10	Stainless steel 1.4435
Conducell 2DC-PG	2 pole contacting	10 µS/cm – 20 mS/cm	-5 – 80 °C	1/cm	6	Graphite
Conducell I	inductive	100 µS/cm - 2000 mS/cm	-10 – 125 °C	6.3/cm	12 (90 °C)	none

Safety First

Hamilton Offers More Certificates Than Ever

Many industrial processes are in hazardous environments and require suitable equipment with the European ATEX or the global IECEx approval. Hamilton provides safe sensors and housings since many years for these applications. In case a gas atmosphere and a dust atmosphere are or could be present at the same time, the risk of explosion must be examined carefully and special precautions may be necessary. Typical gas atmospheres can be found in oil refineries, printing industries and biogas plants. Dust atmospheres can be found in underground coalmines, woodworking areas and in all kind of mills. In the chemical industry both atmospheres can be found.

ATEX is the widely used synonym for the ATEX directives of the European Union. ATEX stands for the French abbreviation

«ATmosphère EXplosible». The objective of ATEX is to ensure the free movement of goods throughout the European Union, by offering one harmonized compliance procedure accepted by all EU countries. This means that different national standards within the EU are obsolete. ATEX covers equipment only. Equipment for hazardous areas requires an ATEX approval when sold within the European Union.

The **IECEx** system is a conformity assessment system of the International Electrical Commission (IEC). It is the objective of the IECEx system to facilitate international trade in equipment and services. Currently Australia, New Zealand, and Singapore accept the IECEx certificate of conformity as meeting all of the national requirements for Ex Certification. No further national certification is required. The IECEx is also accepted in many other countries.

Marking sensors or housings for ATEX / IECEx is as follows:

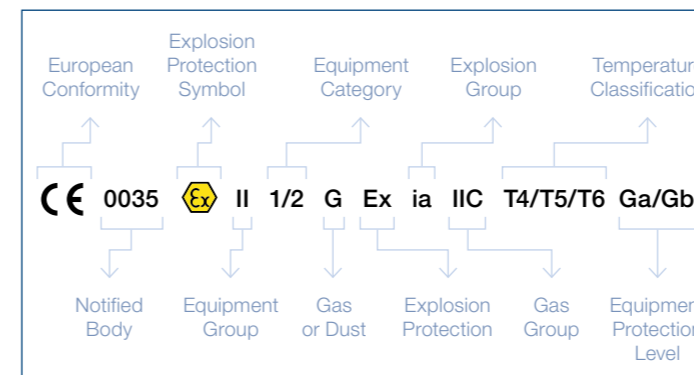

Example OxyFerm FDA
Gas: CE 0035 II 1/2 G Ex ia IIC T4/T5/T6 Ga/Gb
Dust: CE 0035 II 1/2 D Ex ia IIC T x °C Da/Db

The temperature value x in dust atmospheres needs to be calculated.

The table gives an overview of the approvals available for the different product lines. Detailed information about a specific product can be found on the Hamilton website their spec sheets. For general overview please refer to: www.hamiltoncompany.com/support/process-analytics/certificates/products-for-explosive-atmospheres

Sensor / Housing	ATEX		IECEx	
	Gas	Dust	Gas	Dust
Analog Sensors	✓	✓	✓	✓
Housings	✓	✓	✓	✓
Arc	-	-	-	-
Memosens	✓	-	-	-
VisiPro DO	✓	✓	✓	✓



Alphabetical Index

2-pole conductivity sensor	53, 58, 60
3 M KCl	95, 144
4-pole conductivity sensor	53, 54, 56

A	AMP plug	99
	Arc	4, 12, 13, 15, 18, 20, 22, 40, 42, 54, 58, 78, 80, 82, 84
	Arc Accessories	100
	Arc ECS Adapter	99
	Arc Sensor USB Power Cable	99
	Arc View Controller	66, 68, 70
	Arc View Mobile	100
	Arc Wi 1G Adapter BT	100
	Arc Wi 2G Adapter BT	100
	Autoclavation Cap OxyFerm	81, 94

B	Beverly	11, 88
	BINDER plug	99
	BioConnect (BC)	54
	BioControl	117
	Blind plug	137
	Bluetooth	4, 100
	BNC plug	96, 99

C	Cables	96
	Calibration station	77
	Cell Density	6, 65
	ChemoTrode	14, 24, 130, 132, 134
	ChemoTrode Bridge	24, 144
	ChemoTrode ORP	44, 144
	Clark cell	73
	ClaryTrode	18, 144
	Cleaning solution set	95
	Cleaning valve set PVDF/FKM 2 valve	135
	Cleaning valve set PVDF/FKM 3 valve	135
	Conducell 2DC-PG	60
	Conducell 4US	56
	Conducell 4USF	54
	Conducell 4UxF	6, 54
	Conducell I	7, 62
	Conducell UPW	58
	Conductivity	53
	Conductivity pathfinder	53
	Conductivity Standards	10, 92, 93
	Customized Products	101

D	Dencytee	65, 68
	Dencytee Pre-Amp	68
	DO	73
	DO Adapter	138, 139
	DO pathfinder	73
	DuraCal pH buffers	10, 90, 91

E	EasyControl	36, 144
	EasyControl ORP	50, 144
	EasyFerm Bio	22, 144
	EasyFerm Plus	20, 144
	EasyFerm Plus ORP	42, 144
	Electrochemical oxygen sensor	80, 82, 84, 86

Electrolyte	95
-------------	----

F	FDA Service Kit	115
	FermoTrode	26, 144
	FFKM Kit MasterFit	131
	FFKM Kit RetractoFit	113
	Fix Cable	31, 57, 61, 87
	Flange Adapter MasterFit	131
	FlexiFit	110
	FlexiFit Bio	110
	FlexiFit TC 150-33	110
	FlexiFit U Bio	110
	FlexiFit VV-0	110
	FlexiFit VV-15	110
	FlexiFlow SL 10	142
	Flow Cell	140
	Foodlyte	8, 22, 144

H	H100 Cond	104
	H100 DO	105
	H100 pH	103
	H220X	7, 14, 106
	Hamilton Customized Products	101
	Housings	109
	HyCIP	116, 117
	Hygienic Socket	138

I	InchTrode	30, 144
	Incyte	65, 66
	Incyte Pre-Amp	66, 67
	Insertion tube short	113
	IonoTrode	28, 144

K	K8	21, 23, 96, 97
----------	----	----------------

L	Lemo plug	97, 99
	Liq-Glass PG	36, 144
	Liquid Earth	20, 22

M	M12	75, 77, 98, 99
	MasterFit	130, 131
	MasterFit 120	130, 131
	MasterFit 150	130, 131
	MasterFit 250	130, 131
	MecoTrode	32, 144
	Membrane Kit CIP	94
	Membrane Kit FDA	94
	Memosens (MS)	19, 21, 23, 97
	Modbus Profibus Converter	100

O	ODO Cap H0	6, 75, 79
	ODO Cap H2	6, 75, 79
	ODO Cap L0	77
	OneFerm pH	5
	Optical oxygen sensor	74, 76, 78
	O-ring Kit Flow Cell T25	141
	O-ring Kit Flow Cell T50	141
	O-ring set EPDM	139

O-ring set FFKM	139
O-ring set FKM	139
O-ring set Silicone	139
ORP	39
ORP buffers	91
OxyFerm	94, 97
OxyFerm CIP	81
OxyFerm FDA	80, 94
OxyFerm Membrane Kit	94
Oxygen Accessories	94
OxyGold B	82, 94, 95
OxyGold G	84, 94, 95
OxyGold Membrane Kit	94
Oxylyte	95
Oxylyte B	95
Oxylyte G	95
Oxysens	86
OxyTrode Pt	48, 144

P	Panel-mount Kit	103, 104, 105
	Permittivity Simulator	67
	pH	17
	pH buffers	10, 91
	pH glasses	8
	pH pathfinder	17
	Phermylyte	21, 43, 144
	Pipe-mount Kit	103, 104, 105
	Polarization Module	94
	Polarization Module B	94
	Polarization Module G	94
	Polarization Module T	94
	Polilyte HT	18, 144
	Polilyte Plus	9, 18, 20, 21, 144
	Polilyte Plus ORP	40, 144
	Polilyte Plus XP	19, 144
	Polilyte Pro	34, 144
	Polilyte RX	48, 144
	Polisolve	31, 35, 49, 144
	Polisolve Plus	9, 19, 41, 144
	Polyclave	18, 144
	Polyplast Pro	34, 144
	Polyplast Pro RX	48, 144
	Post Mounting Set	135
	Pressure Adapter	131, 133
	Protective Hood	103, 104, 105
	Protelyte	95
	PTFE scraper	118, 120, 122, 124, 126, 128

R	Replacement Cathode OxyFerm	94
	Replacement Cathode OxyGold B	94
	Replacement Cathode OxyGold G	94
	Replacement Kit Seal Pusher	139
	Retractable	116, 117, 118, 119, 120, 121, 122, 123, 124, 125, 126, 127, 128, 129, 134
	Retractable B	116, 117
	Retractable B (pneumatic)	117
	Retractable B M (manual)	117
	Retractable BC	118, 119, 120, 121

Retractable BC Plastic	120, 121
Retractable BC Plastic (pneumatic)	121
Retractable BC Plastic M (manual)	121
Retractable BC Steel	118, 119
Retractable BC Steel (pneumatic)	119
Retractable BC Steel M (manual)	119
Retractable C	122, 123, 124, 125, 126, 127, 128, 129
Retractable C Plastic	124, 125, 128, 129
Retractable C Plastic (pneumatic)	125
Retractable C Plastic LT (pneumatic)	129
Retractable C Plastic LT M (manual)	129
Retractable C Plastic M (manual)	125
Retractable C Steel	122, 123, 126, 127
Retractable C Steel (pneumatic)	123
Retractable C Steel LT	126, 127
Retractable C Steel LT (pneumatic)	127
Retractable C Steel LT M (manual)	127
Retractable C Steel M (manual)	123
RetractoControl Plus	134, 135
RetractoFit	112, 113
RetractoFit Bio	114, 115
RetractoFit Bio 25	115
RetractoFit Bio 55	115
RetractoFit PEEK 25	112
RetractoMaster	132

S	S7	24, 27, 29, 45, 96
	S8	19, 21, 23, 33, 35, 37, 41, 43, 47, 49, 51
	Safety Socket	136, 137
	Sensor Cable M12	98
	Sensor Power Cable M12	99
	Service Kit FFKM	111
	Service Kit FlexiFit Bio	111
	Service Kit MasterFit	131
	Service Kit RetractoFit	113
	Single Pore	9, 19, 31, 35, 41, 49, 144
	Skylyte	25, 27, 95
	Storage solution	95
	System Installations	14, 15

T	T82/D4	81, 97
	Transmitter	100, 101, 102, 103, 104, 105
	Triclamp (TC)	56, 58, 59, 108, 115, 134, 135

V	Varivent (VV)	54, 55, 108, 115
	VisiFerm DO	5, 6, 11, 78, 98
	VisiFerm DO SU	5
	VisiPro Do Ex	6, 74, 100
	VisiTrace	76
	VP	21, 23, 25, 29, 31, 33, 35, 55, 59, 81, 83, 85
	VP 6	25, 31, 33, 35, 55, 59, 81, 83, 93, 97
	VP 8	98, 99

W	Wall Mounting Set (plastic housing)	135
	Wall Mounting Set (stainless steel housing)	135
	Weld-in socket	137
	Wireless Converter BT	100



BioConnect® is a registered trademark of NEUMO GmbH + Co. KG, Knittlingen (D).

Bluetooth® is a registered trademark of Bluetooth SIG Inc., Kirkland WA, USA.

Knick® is a registered trademark by KNICK Elektronische Messgeräte, Berlin (D).

Memosens® is a registered trademark of Endress + Hauser, Reinach (D).

Tuchenhagen Varivent® is a registered trademark of GEA Tuchenhagen GmbH.

Unigate® is a registered trademark of Deutschmann Automation GmbH & Co. KG, Bad Camberg (D).

App Store, iOS, and their logos are registered trademarks of Apple Inc. in the US and other countries.

Android, Google Play, and their logos are registered trademarks of Google Inc. in the US and/or other countries.

Windows and their logos are registered trademarks of Microsoft Corporation in the US and other countries.

All other trademarks are owned and/or registered by Hamilton Bonaduz AG.



HAMILTON 

Web: www.hamiltoncompany.com

USA: 800-648-5950

Europe: +41-58-610-10-10

Hamilton Americas & Pacific Rim

Hamilton Company Inc.
4970 Energy Way
Reno, Nevada 89502 USA
Tel: +1-775-858-3000
Fax: +1-775-856-7259
sales@hamiltoncompany.com

Hamilton Europe, Asia & Africa

Hamilton Bonaduz AG
Via Crusch 8
CH-7402 Bonaduz, Switzerland
Tel: +41-58-610-10-10
Fax: +41-58-610-00-10
contact.pa.ch@hamilton.ch

To find a representative in your area, please visit www.hamiltoncompany.com.