

This publication supersedes and replaces any previous edition and revision. All rights reserved. No part of this publication may be reproduced, stored in a retrieval system or transmitted in any form or by any means, electronic, mechanical, photocopying, recording or otherwise, without permission of Tecnicam s.r.l. (Bologna - Italy). The technical data, the images and the diagrams are exclusively indicative and not binding, they might be modified without notice.

# 5000H

## High speed strip packaging horizontal machine

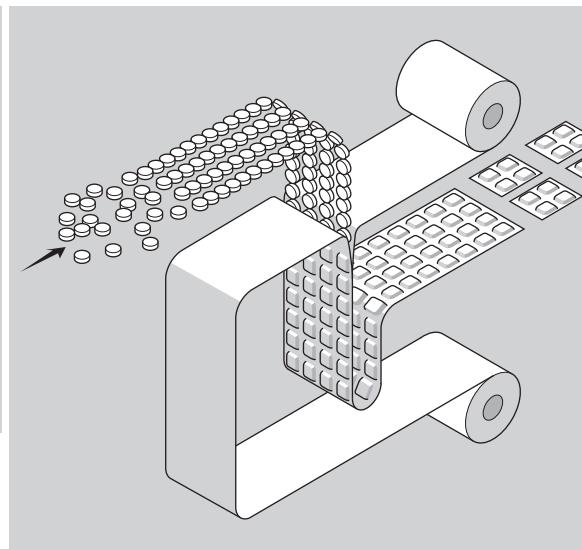
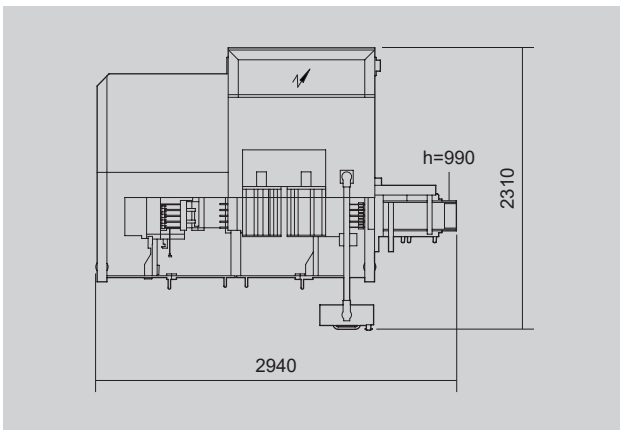
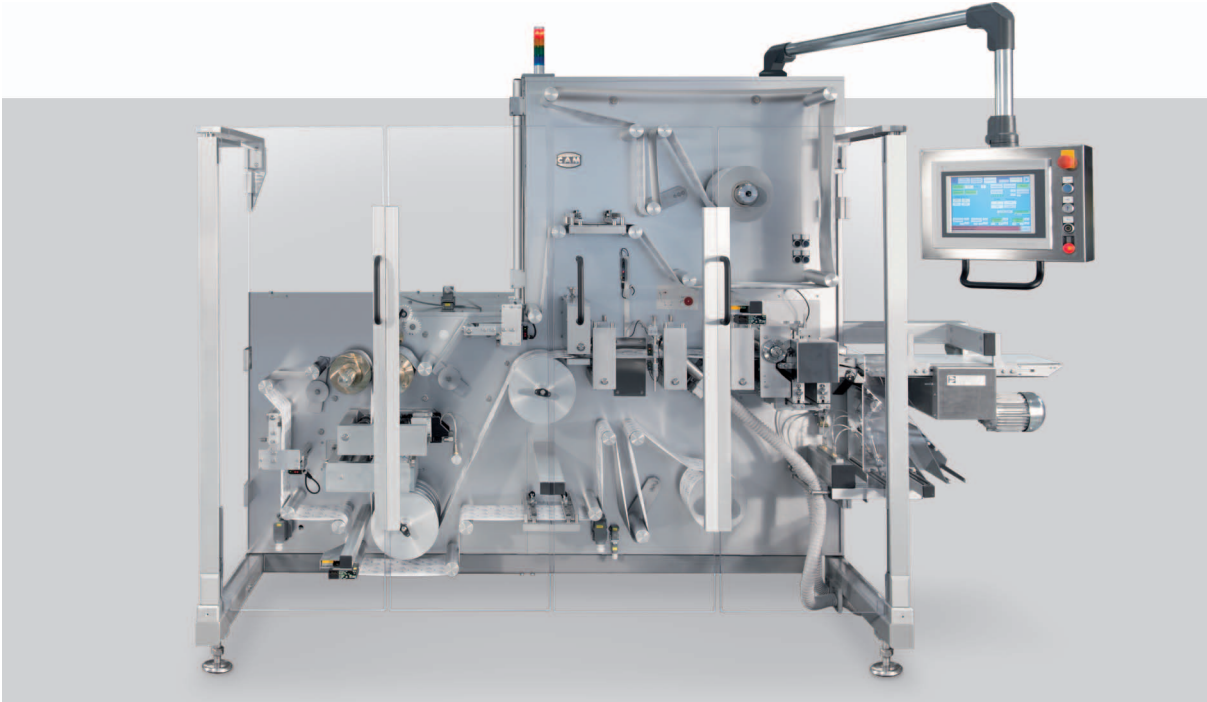

TECHNICAL DATA		5000/200H	5000/400H
Mechanical speed	<b>STROKES/1'</b>	300 (Depending on package size)	300
Power absorption	<b>KW</b>	9	12
Air consumption	<b>NI/1'</b>	180	180
Air pressure	<b>bar</b>	6+8	6+8
Gross weight	<b>kg</b>	~2500	~3000
Size range			
	<b>5000/200H min. max.</b>	<b>5000/400H min. max.</b>	
<b>A</b>	35 190	35 390	
<b>C</b>	Programmable	Programmable	
<b>L (Reel width)</b>	- 200	- 400	

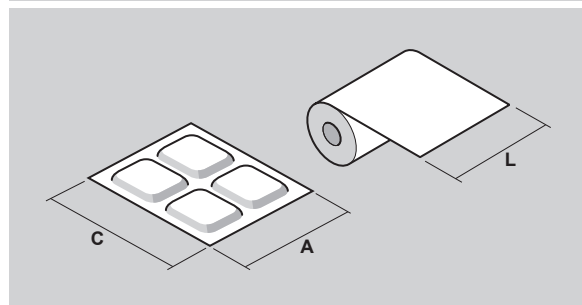

FM-5000H-02-uk (10/02/2018)