



Pharmaceutical primary packaging

Plastic packaging solutions
for liquid formulations

gerresheimer.com

gerresheimer
innovating for a better life

About Gerresheimer

Innovating for a better life

Gerresheimer is the global partner for pharma, biotech, healthcare and beauty with a very broad product range for pharmaceutical and cosmetic packaging and drug delivery devices.

The company is an innovative solution provider from concept to delivery of the end product. Gerresheimer achieves its ambitious goals through a high level of innovative strength, industrial competence, focus on quality and customers.

In developing innovative and sustainable solutions, Gerresheimer relies on a comprehensive international network with numerous innovation and production centers in Europe, America and Asia. Gerresheimer produces close to its customers worldwide with around 10,000 employees and generates annual sales of more than €1.4 billion. With its products and solutions, Gerresheimer plays an essential role in people's health and well-being.

Plastic packaging solutions for diverse pharmaceutical applications

Gerresheimer Primary Packaging Plastics specializes in the widely varied spectrum of pharmaceutical plastic packaging within solid, liquid and ophthalmic applications, plastic vials and plastic bottles for personal care.

Our leading brands Duma®, Dudek™ and Triveni for solid dosage, edp-branded PET bottles for liquid dosage and our ophthalmic products form part of a comprehensive and innovative product range. Our monolayer plastic vials are based on COP and offer inert contact surface and deliver a unique packaging safety feature to manufacturers of

toxic or high potency drug solutions. Our standard range includes a wide choice of different types of containers and closures, PET bottles, eye droppers, nasal sprays, nebulizers, applicators, accessories as well as numerous customized developments.

Using our ideas and experience to produce intelligent, increasingly safe and user-friendly packaging solutions has enabled us to become an innovative partner to the global pharmaceutical industry. We know, understand and reinforce our customers business.

Liquid formulations



Solid formulations



Ophthalmic and nasal applications



Sustainable plastic packaging



Gerresheimer Zaragoza pharma focused company with clean room

- Single source provider of bottles and caps manufactured in an ISO class 8 clean room
- Further quality and stability enhancements
- Improved production processes with new machines and molds
- ISO certifications (ISO 9001 and ISO 15378)



Plastic materials

PET | R-PET | BIO-PET

As Gerresheimer Plastic Packaging is committed to environmental concerns we offer our PET ranges with different mixtures of post-consumer recycled materials.

We can produce bottles made of up to 100% R-PET.

Ecological aspects

Besides using recycled materials, Gerresheimer is also motivated to help our customers contribute to the reduction of greenhouse gas emissions by using biomaterials. Biomaterials are the renewable alternative to conventional PE/PET.

Sugarcane is one of the substances used to make biomaterials. You take the ethanol from the sugarcane plant and then put it through a dehydration process to transform it into green ethylene. Afterwards the green ethylene goes to the polymerization plants, where it is converted into green PE/PET.



Technical features

- ISBM technology
- PET, R-PET, BIO-PET
- bottles available in different colors
- Different mixtures of post-consumer recycled materials
- 3D CAD design software
- ISO 9001





Strong regulatory approach

We ensure full conformity of our products with the European pharmacopoeia, the United States pharmacopoeia and the requirements for FDA registration with a Drug Master File as the standard. Knowing the extensive requirements of our customers we focus on providing a high level of documentation with our products.

- High level of documentation and registration
- Standard product database
- FDA and world-wide registration of all products
- US and Canada Drug Master File
- Product registrations in Russia, China and the Ukraine
- Food approval

Strong quality culture

A strong quality culture supports our efforts to deliver excellent quality. The culture is defined by our shared beliefs, values and behaviour patterns.

- Quality attitude and team work
- Continuous improvements
- Systematic problem solving
- Quality by design
- Stable, robust, reliable and validated processes
- Risk-based approach

Specialist and quality leader in primary plastic packaging

Our manufacturing operations use state-of-the-art technology and apply the most rigorous quality and hygiene standards. They cover all production technologies from injection moulding and injection blow moulding to blow moulding processes. The majority of our production

operations are carried out in modern classified clean-rooms or in clean conditions. All plants apply the rules of Good Manufacturing Practice (GMP) and are certified in accordance with ISO standards.

- Solution providing
- Good Manufacturing Practice (GMP)
- ISO certifications
(ISO 9001, ISO 15378, ISO 14001, ISO 45001)
- Automated in-line controls
- Vision-based inspection system
- Class 7 (10,000) + class 8 (100,000) clean-rooms



Innovating for a better life



Success through constant innovation

- Cover your needs with wide product family
- Full solutions with less material and same properties
- Competitive advantage via product differentiation
- Solution provider to customer challenges
- Vision for identifying future customer needs



Reliability through excellent quality

- Strong quality culture based on right first time
- Deliver best-in-class products and services and a high level of documentation
- Strong regulatory platform and conform with EP and USP
- Certified according to relevant ISO standards and operate in classified clean rooms
- Deep understanding of patient safety and customer requirements



Understanding through technical competence

- Complete solution provider and partner for new projects
- Extensive experience and know-how
- Optimized processes with high quality molds and machines
- Support with auxiliary processes e.g., sterilization
- Excellent technical support in order to run your production smoothly



Flexibility through global presence

- One supplier and one responsibility
- Understanding local market needs and regulations
- Uniform and state-of-the-art manufacturing conditions
- Global lean organization increasing the speed to market
- Easy transfer of production to another region



Performance through commitment to sustainability

- We Rethink our processes and products for a more sustainable future
- We recycle our production waste 100%
- We design for recycling for over 20 years
- We challenge our suppliers social and economic impacts on carbon footprint
- We are standing for the healthy and social well-being of our employees

Liquid fomulations



Liquid fomulations



We offer a comprehensive range of edp-branded PET bottles for liquids and closures in HDPE and PP for different applications.

All our bottles can be supplied with caps, reducers and other accessories. Some are optionally available with a measuring cup that has a 2.5 to 10 ml scale or a measuring cup with a 5 to 20 ml scale. Some of our products are even compatible with glass accessories/bottles.

You can opt for one of the products in the standard range or design a product customized to your needs and requirements with our R&D team.

- PET bottles for liquid – EDP brand
- PET containers for solid – Duma® PET
- PET bottles for oral care
- Caps and measuring cups for PP18 neck, PP28 neck & Duma® PET
- Customized shapes
- Different colours available
- PP18 and PP28 caps compatible with glass, PE & PP solutions
- UV filter
- FDA registered, DMF type III, DMF no. 22946, US Drug Master File (DMF)
- Recycled materials

Solid



Oral Care



Accessories



ST bottles PP18 neck



specifications

Ref.#	ml	ml	mm	mm	mm	Ref.#
ST10 PP18 PET 4,5	1104	10	14,8	23,0	54	PP18 10088
ST15 PP18 PET 4,5	1105	15	21,0	24,6	63	PP18 10088
ST30 PP18 PET 5,8	900	30	35,2	29,0	75	PP18 10088
ST50 PP18 PET 8	910	50	60,0	37,3	80	PP18 10088

- Material: Bottle PET, tamper-evident cap PP
- 4 ST bottles PP18 neck sizes ranging from 10–50 ml
- Can be supplied with other caps and reducers
- Bottles available in different colors

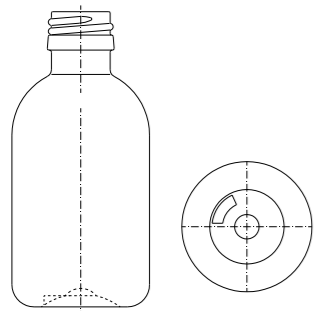

ST bottles PP28 neck



specifications

Ref.#	ml	ml	mm	mm	mm	Ref.#	Ref.#
ST100 PP28ST PET 17	1103	100	119,5	46,0	100,5	PP28ST 10089	10100 / 10108
ST200 PP28ST PET 21	1094	200	222,0	55,3	125,0	PP28ST 10089	10100 / 10108
ST250 PP28ST PET 28	140	250	270,0	55,0	148,0	PP28ST 10089	10100 / 10108
ST300 PP28ST PET 27,5	1006	300	315,0	60,0	147,0	PP28ST 10089	10100 / 10108
ST500 PP28ST PET 35	1090	500	521,0	68,5	179,0	PP28ST 10089	10100 / 10108
ST600 PP28ST PET 53	472	600	630,0	76,0	182,0	PP28ST 10089	10100 / 10108
ST1000 PP28ST PET 57	1002	1000	1030,0	85,1	227,8	PP28ST 10089	10100 / 10108

- Material: bottle PET, tamper-evident cap PP, measuring cup PP
- Can be supplied with other caps and reducers
- Measuring cup can be supplied with the scale from 5 ml to 20 ml in clear (10108) and white (10100) colour
- Bottles available in different colours

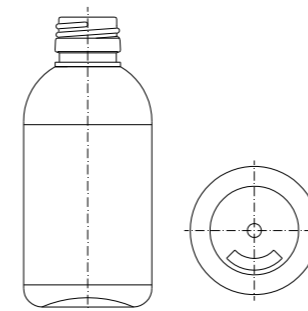

PF bottles PP28 neck



specifications

Ref.#	ml	ml	mm	mm	mm	Ref.#	Ref.#
PF60 PP28ST PET 11,8 161	60	80,0	38,0	95,5	PP28ST	10089	10100 / 10108
PF 90 PP28ST PET 15 1110	90	97,5	40,7	101,6	PP28ST	10089	10100 / 10108
PF100 PP28ST PET 17 1093	100	115,0	44,1	107,0	PP28ST	10089	10100 / 10108
PF120 PP28ST PET 17,5 163	120	150,0	48,0	115,5	PP28ST	10089	10100 / 10108
PF150 PP28ST PET 17,5 164	150	175,0	49,0	126,1	PP28ST	10089	10100 / 10108
PF200 PP28ST PET 24 1095	200	222,5	52,1	144,5	PP28ST	10089	10100 / 10108
PF250 PP28ST PET 24 1096	250	283,0	58,0	147,7	PP28ST	10089	10100 / 10108
PF300 PP28ST PET 24 1123	300	313,0	60,6	145,5	PP28ST	10089	10100 / 10108
PF500 PP28ST PET 35 1089	500	526,0	70,0	180,0	PP28ST	10089	10100 / 10108

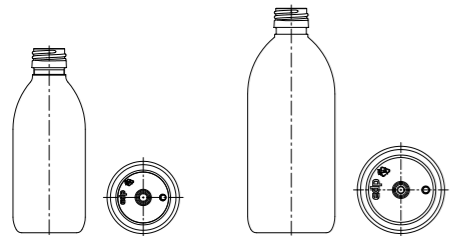

- Material: bottle PET, tamper-evident cap PP, measuring cup PP
- Can be supplied with other caps and reducers
- Measuring cup can be supplied with the scale from 5 ml to 20 ml in clear (10108) and white (10100) colour
- Bottles available in different colours

LP bottles PP28 neck



specifications

Ref.#	ml	ml	mm	mm	mm	Ref.#	Ref.#
LP150 PP28ST PET 21 520	150	170,5	52,5	112,75	PP28ST	10089	10100 / 10108
LP500 PP28ST PET 35 1091	500	520,5	69,5	179,00	PP28ST	10089	10100 / 10108
LP1000 PP28ST PET 50 1124	1000	1050,0	88,0	218,00	PP28ST	10089	10100 / 10108

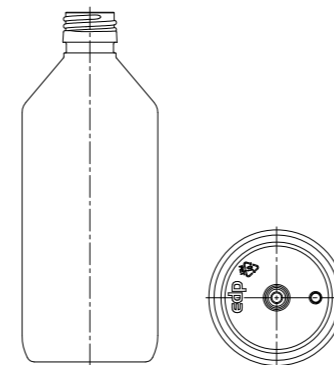

- Material: bottle PET, tamper-evident cap PP, measuring cup PP
- Can be supplied with other caps and reducers
- Measuring cup can be supplied with the scale from 5 ml to 20 ml in clear (10108) and white (10100) colour
- Bottles available in different colours

OM bottles PP18 and PP28 neck



specifications

Ref.#	ml	ml	mm	mm	mm	Ref.#	Ref.#
OM15 PP18 PET 4,5	1117	15	20	25,5	56,35	PP18	10088
OM250 PP28ST PET 24	1111	250	272	61,7	127,50	PP28ST	10089 10100 / 10108

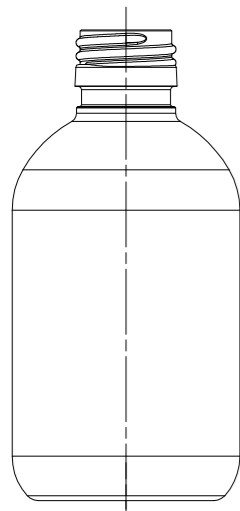

- Material: bottle PET, tamper-evident cap PP, measuring cup PP
- Can be supplied with other caps and reducers
- Measuring cup can be supplied with the scale from 5 ml to 20 ml in clear (10108) and white (10100) colour
- Bottles available in different colours

PL bottles PP28 neck



specifications

Ref.#	ml	ml	mm	mm	mm	Ref.#	Ref.#
37101	100	119	47	103	PP28	15127	41010
37126	125	150	48	116	PP28	15127	41010
37151	150	200	54	122	PP28	15127	41010
37251	250	300	58	153	PP28	15127	41010

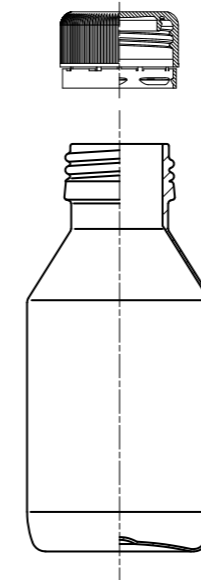

- Material: bottle PET, tamper-evident screw cap PE, measuring cup PP
- Bottles available in amber, white, clear
- Measuring cup with scale available from 2,5 ml to 10 ml
- Suited to standard filling and packaging equipment
- Manufactured under clean-room conditions

Duma® PET



specifications

Ref.#	ml	mm	mm	mm	Label mm	Ref.#	Int. Des.* Ref.#	
DUMAPET 75 17	1058	75	45,5	73,0	33	37,7	4015	4015
DUMAPET 100 17	1036	100	45,5	89,5	33	54,0	4015	4015
DUMAPET 125 20	1037	125	48,7	96,5	33	58,5	4015	4015
DUMAPET 150 20	1038	150	51,4	100,0	33	61,5	4015	4015

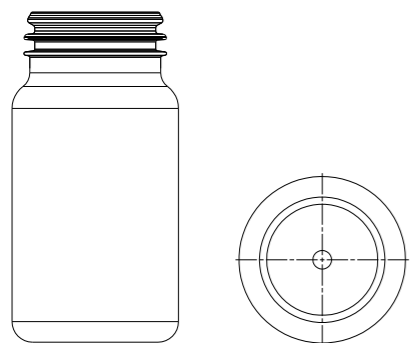

- Material: bottle PET, cap LDPE
- Bottles available in different colours
- Snap lock system
- Handy cap easy-open system
- Tamper-evident
- Available with integrated desiccant 4 g
- Caps available in different colours

Mouthwash



specifications

Ref.#	ml	ml	mm	mm	mm	
COL500 M1759 PET 41	724	500	545	83 x 46	224	M1759
COL500 M1759 PET 41	538	500	524	81,6 x 50	227	M1759

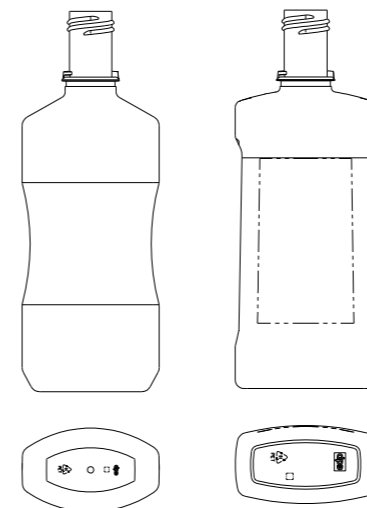

- PET bottles
- Can be supplied with cap



Complements



PP18

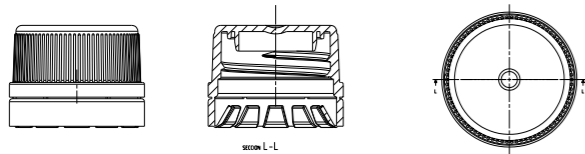

- Material: tamper-evident cap PP
- Suitable for ST bottles PP18 neck (see page 10) and OM bottle 15 ml (see page 15)
- Ref 10088 on page 10 and 15 corresponds to PP18 cap



PP28

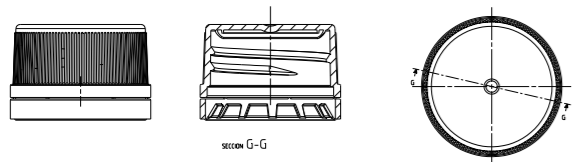

- Material: tamper-evident cap PP
- Suitable for ST, PF, LP, OM bottles PP28 neck (see pages 11, 13, 14 and 15)
- Ref 10089 on pages 11, 13, 14 and 15 corresponds to PP28 cap

Measuring Cup

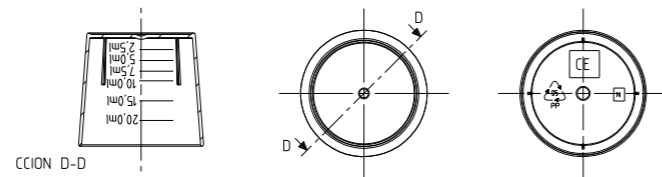

- Material: measuring cup PP
- Measuring cup from 5 ml to 20 ml available in white and clear
- Ref 10100 and 10108 on pages 11, 13, 14 and 15 correspond to PP28 measuring cup

Complements



Duma® Handy cap

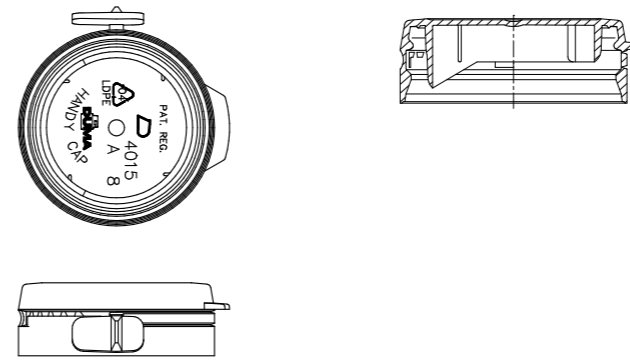

- Material: cap LDPE
- Suitable for Duma® PET containers (see page 17)
- Snap lock system
- Handy Cap easy-open system
- Tamper-evident
- Available with integrated desiccant 4 g
- Caps available in different colours
- Ref 4015 on page 17 corresponds to Duma® Handy Cap



PL bottles
PP28 neck

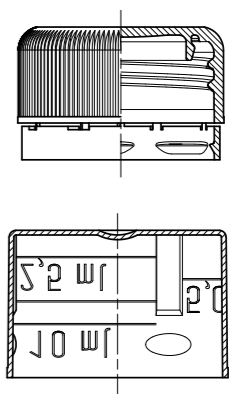

- Material: tamper-evident screw cap PE, measuring cup PP
- Suitable for PL bottles PP28 neck (see page 16)
- Ref 15127 on page 16 corresponds to the cap
- Ref 41010 on page 16 corresponds to the measuring cup

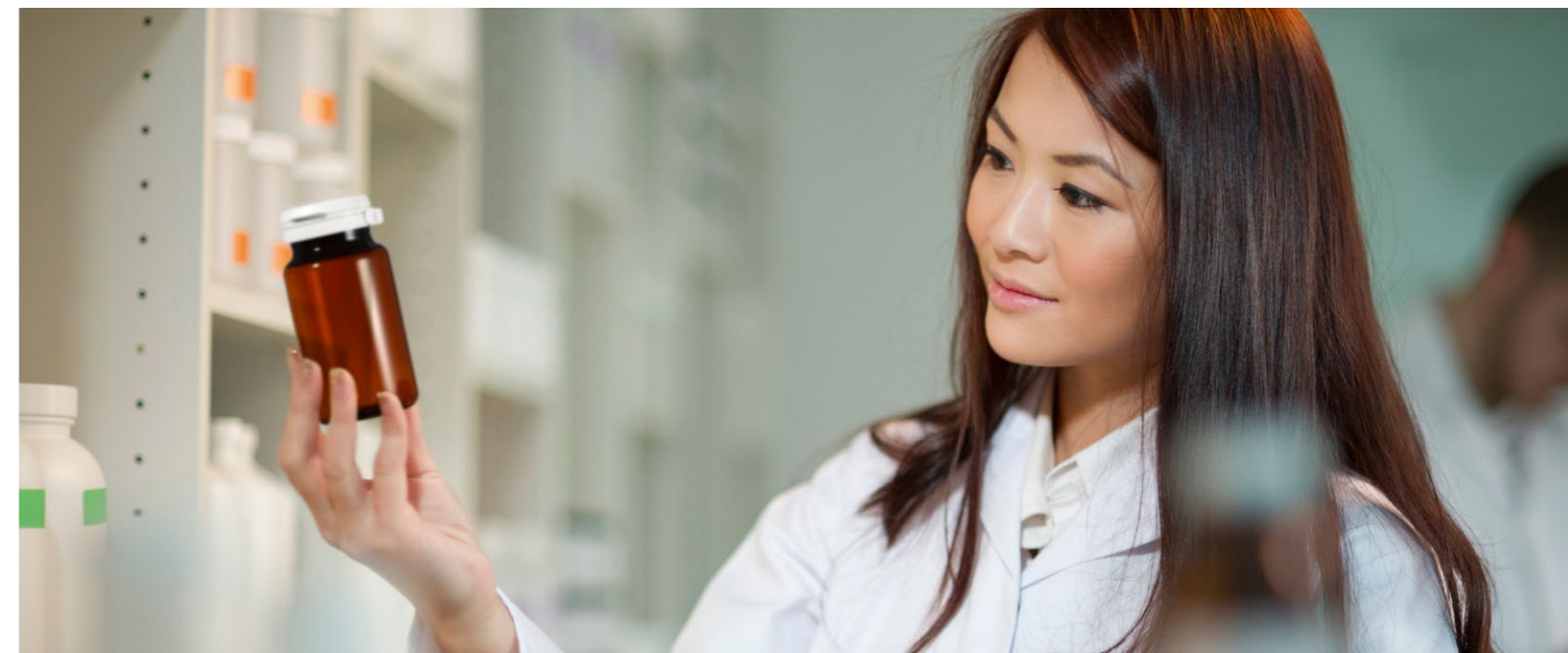

Standard and custom molding

Gerresheimer has a dedicated and committed R&D department

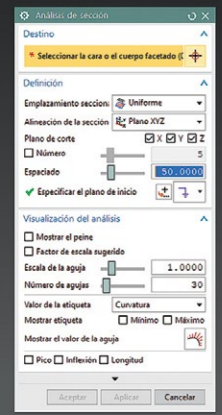

Product Design

Gerresheimer offers a wide range of services to generate product designs from initial product concept to the final shape. It is a process through final tool design 3D CAD software providing photo realistic rendered images. We can also propose mock ups for this initial stage.

Technical Evaluations

We offer a full service, covering all technical and commercial aspects, from the unit tool to the first samples produced in the industrial mold. Our engineers have a vast experience and knowledge of product development.

Service

We are customer-oriented, working hand by hand from the first draft to the production in our customers' filling line.

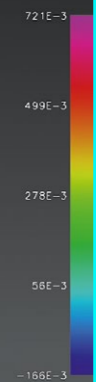
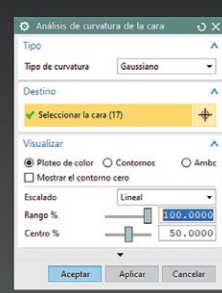

Customized

We offer unique diversity even in the standard range and we are happy to develop products for individual needs and requirements. Our machines give us maximum flexibility and allow us to adapt easily to any size of product series.

We cooperate with experienced coloring partners and we have the capability to develop specific master batches within short notice for pharma and para-pharmacy products.

We can also support our customers offering them outsourced service of sterilisation and decoration.

Gerresheimer worldwide

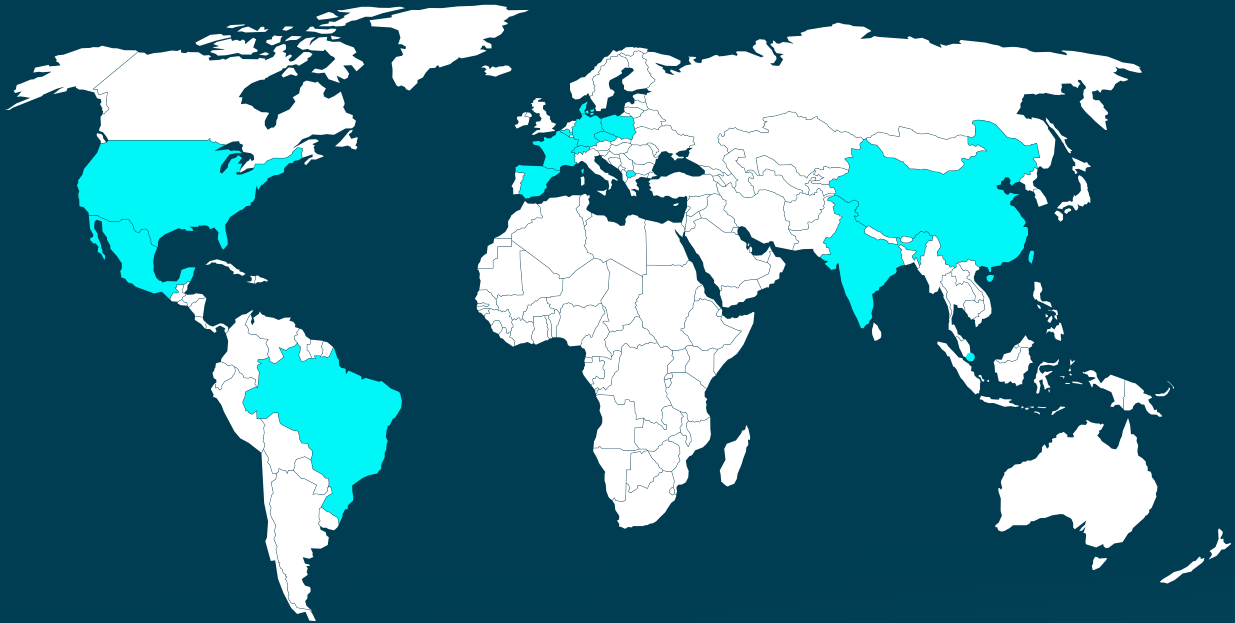

Primary Packaging Plastics

North America

Centor Inc.

5091 County Road 120
44610 Berlin, OH (USA)
Tel. +1 404 376 8157

South America

Gerresheimer Plásticos São Paulo Ltda

Rua Mario Regalo Pereira,
Nr. 160 and 170
05550-060 Butantã, São Paulo (Brazil)
Tel. +55 11 3783 83 50

Gerresheimer Plásticos São Paulo Ltda

VP 3 E S/N. Qd 06 A Módulo 02
Barreiro do Meio –
Distrito Agroindustrial
75132-100 Anápolis (Brazil)
Tel. +55 62 3142-2555

Europe

Gerresheimer Vaerloese A/S

Walgerholm 2-8
3500 Vaerloese (Denmark)
Strandgade 87
5683 Haarby (Denmark)
Tel. +45 4477 7888

Gerresheimer Boleslawiec S.A.

ul. Boleslawa Chrobrego 15
59-700 Boleslawiec (Poland)
Tel. +48 75 735 04 00

Gerresheimer Zaragoza S.L.U.

P.I. Valdemuel
Camino del Sabinar, s/n
50290 Epila, Zaragoza (Spain)
Tel. +34 976 817 408

Asia

Triveni Polymers Pvt. Ltd.

Kundli Plant, Haryana
G.T. Road, Piao Maniyari
Kundli-131028 Distr. Sonapat
Haryana (India)
Tel. +91 130 2219070

Triveni Polymers Pvt. Ltd.

Village Kunwarda, Taluka Mangrol
Kosamba (R.S.), Distr. Surat
394120 Gujarat (India)
Tel. +91 264 6270664

Gerresheimer Singapore Pte. Ltd.

1 Paya Lebar Link,
Paya Lebar Quarter 1, 4th floor No.1
Singapore 408533
Tel. +65 6955 8639

Gerresheimer Plastic Packaging (Changzhou) Co., Ltd.

No. 280, Fumin Road, Lucheng Street
Changzhou City, Jiangsu Province
(China)
Tel. +86 139 1530 6010

More information:

info-plasticpackaging@gerresheimer.com

gerresheimer.com

Pharmaceutical Plastic Packaging
and Systems for South America is
to be found in a separate catalogue