



Wrap-around labeling of COVID-19 vaccines

Performance, reliability, availability

Speed is the key: this has rarely been as important as it is now in the global distribution of COVID-19 vaccines. You can label many millions of vials in a very short time with the 132M HC wrap-around labeler. With the highest precision and performance, and with absolute process reliability in compliance with the stringent requirements of the healthcare industry.

And it gets even better: Its modular design makes the machine highly flexible. It is therefore available at short notice - as is a reliably labeled vaccine. With wrap-around labeling of up to 400 products per minute and, if desired, reel change-over without downtime, you can master your part of what is probably the most important task at present.



Short
delivery
time

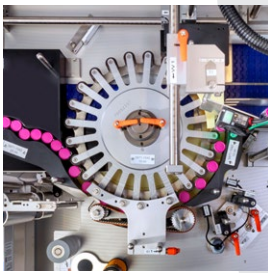
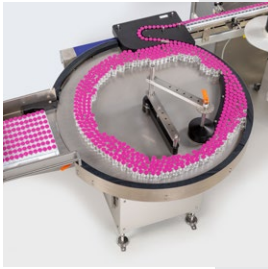

Benefits at a glance

- Fully automatic high-performance wrap-around labeling with maximum functional reliability and process control
- Speeds of up to 400 products per minute
- High-performance HERMA 500 labeler as central module
- Rejection of labels detected as bad and of vials without label
- Optional: turntable at infeed and outfeed with magazine holder for complete trays
- Optional: EasyCutter and EasySplicer for almost continuous operation
- Future-proof thanks to fast changeovers with toolless format part changes and digital position indicators

Technical data

| | |
|-------------------------|---|
| Labeling type: | Wrap-around labeling |
| Product specifications: | Cylindrical, free-standing |
| Product dimensions: | 14.75 - 100 x 36 - 230 mm (D x H) |
| Label dimensions: | 10 - 80 x 30 - 265 mm (W x L) |
| Capacity: | Up to 400 products/minute |
| Power supply: | 400 V, TN-C-S, 50 Hz, 3 phases 208 V, delta 4-wire, 60 Hz, 3 phases (optional) |
| Compressed air supply: | 6 bar |
| Printer: | Videojet, Markem Imaje, Allen Coding, Domino, etc. |
| Camera: | Laetus, Cognex, Vision Automation, Mettler Toledo PCE, Systec, etc. |
| Components: | Control panel with 12 inch touchscreen, conveyor belt, side guides for products, infeed queue check, starwheel, labeler HERMA 500, print and code check, label presence check, product reject station, outfeed jam check, Siemens- or Allen-Bradley control, signal column, transparent machine guard, interface for remote maintenance |
| Options: | Rotary table, EasyCutter, EasySplicer, in-process control, data providing for batch report, audit trail, qualification |
| Note: | If optional features are chosen, the above data may vary |

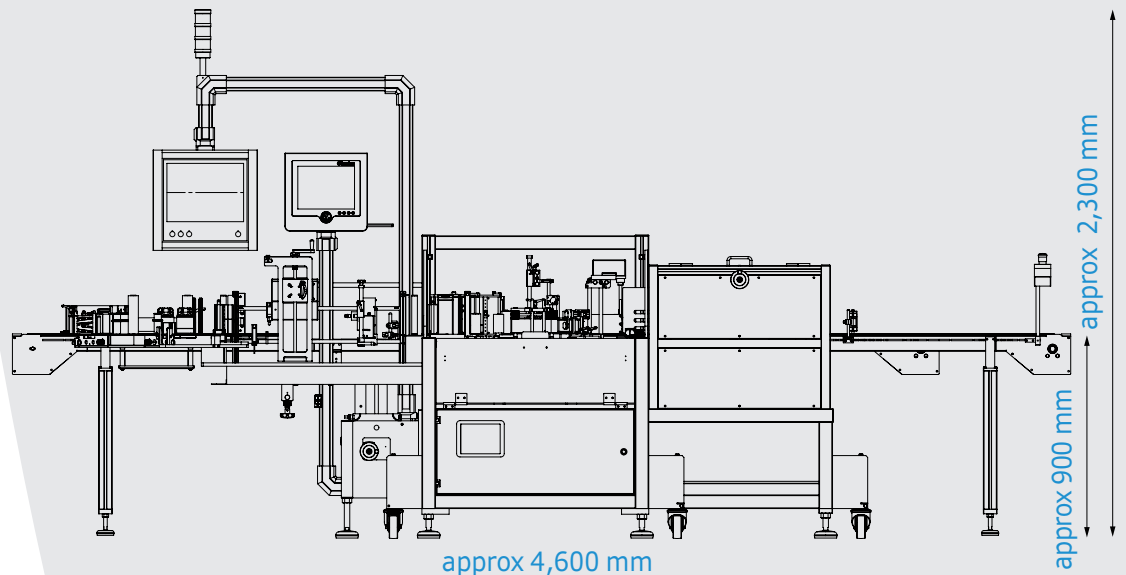

132M HC video

HERMA GmbH
Labeling Machines Division

Heinrich-Hermann-Straße 14
D-70794 Filderstadt

Tel. +49 (0) 711 / 7702-6012

www.herma.com/machines
machines@herma.com