

This publication supersedes and replaces any previous edition and revision. All rights reserved. No part of this publication may be reproduced, stored in a retrieval system or transmitted in any form or by any means, electronic, mechanical, photocopying, recording or otherwise, without permission of Tecnicam s.r.l. (Bologna - Italy). The technical data, the images and the diagrams are exclusively indicative and not binding, they might be modified without notice.

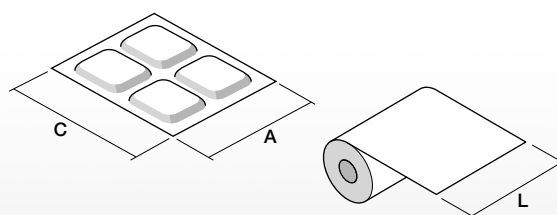

# 5000H

## HIGH SPEED STRIP PACKAGING HORIZONTAL MACHINE

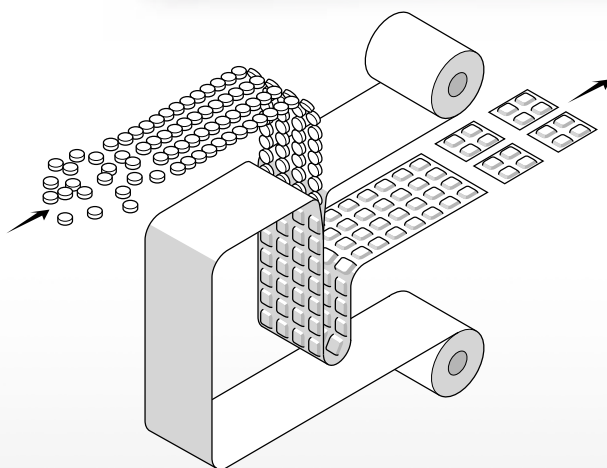

TECHNICAL DATA		5000/200H	5000/400H
Mechanical speed	STROKES/1'	300*	300*
Power absorption	kW	9	12
Air consumption	NI/1'	180	180
Air pressure	bar	6-8	6-8
Net weight	kg	1700	1700

\* Depending on package size

Size range		Min. / Max.	Min. / Max.
A	[mm]	35 / 190	35 / 390
B	[mm]	Programmable	Programmable
L	(Reel width)	- / 200	- / 400

