

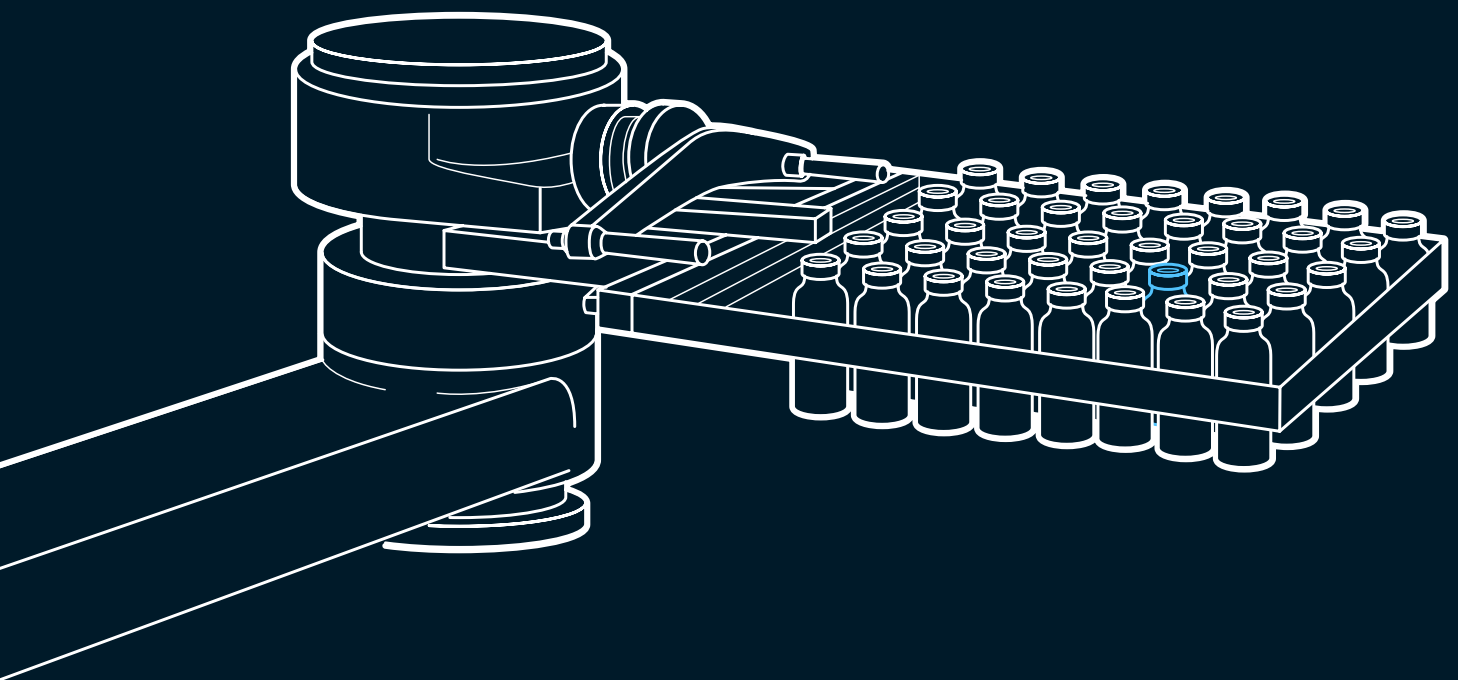

**Drug Product
Contract Manufacturing Services**

Robotic Gloveless
GMP Fill & Finish for Sterile Injectables



Formulation: Isolator

Formulation development and production



Scan or click to learn more

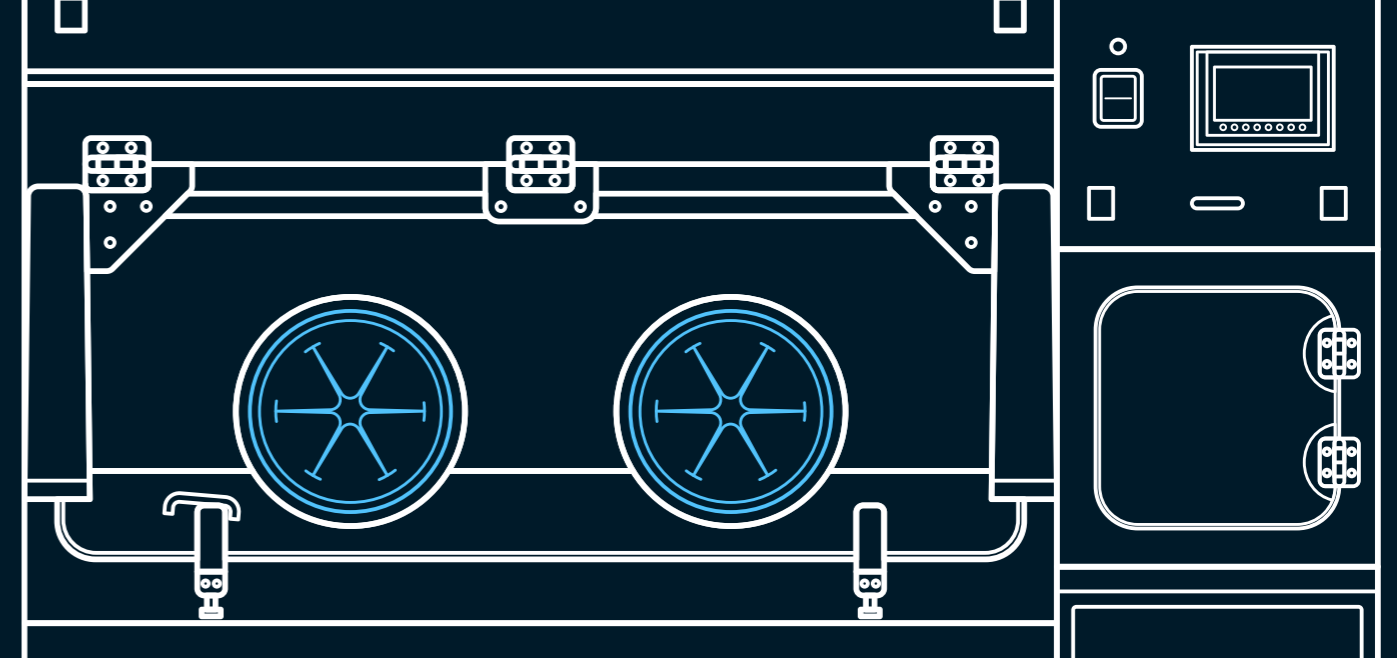

Key Features

High containment unit to perform sensitive weighing or formulation activities

H14 HEPA air filtration.

H2O2 decontamination system.

RTP port connection.

Airlock with dedicated decontamination system.

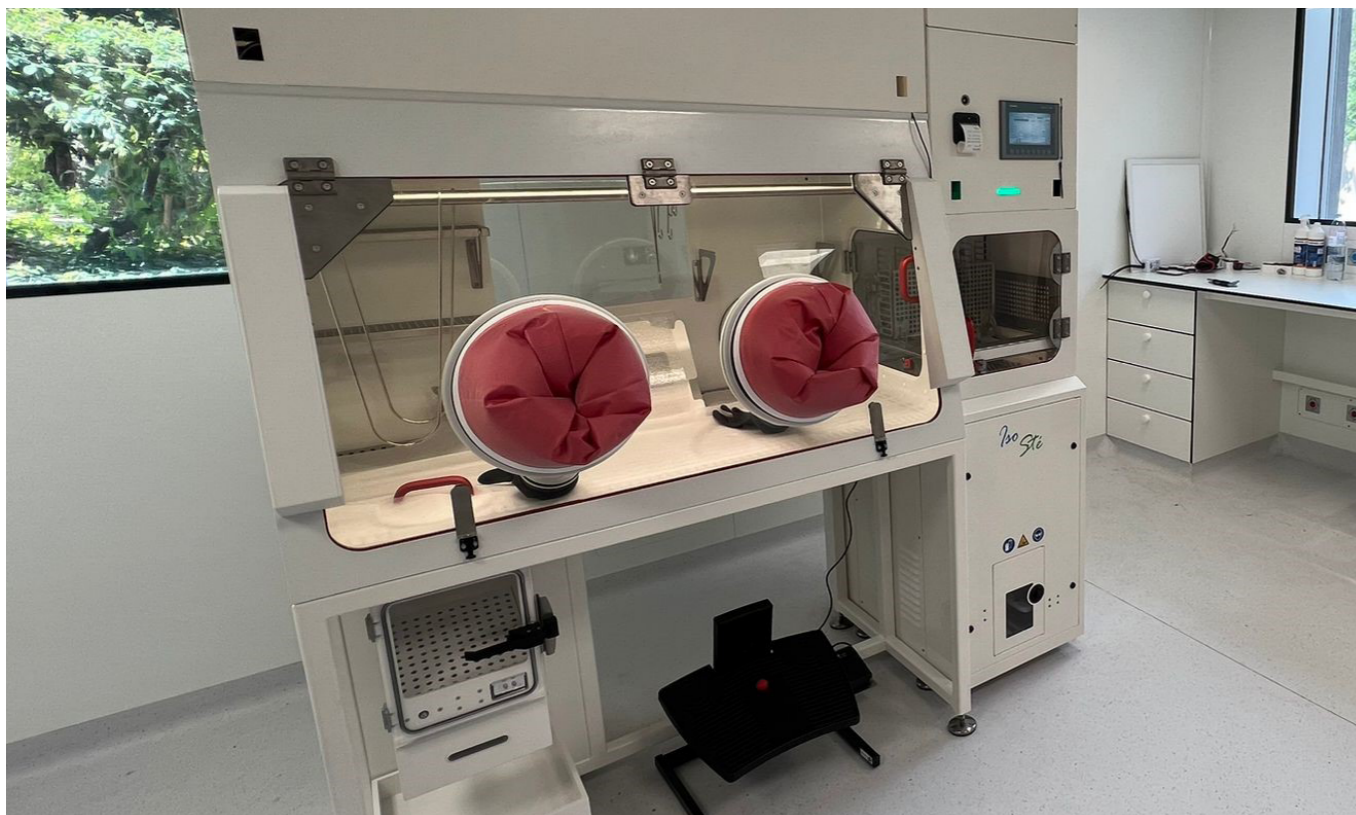

Specifications & range

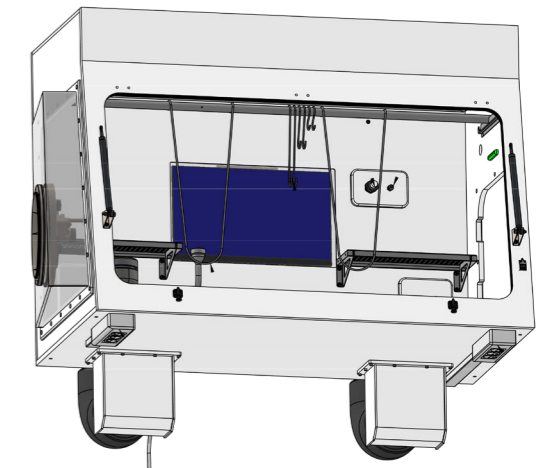
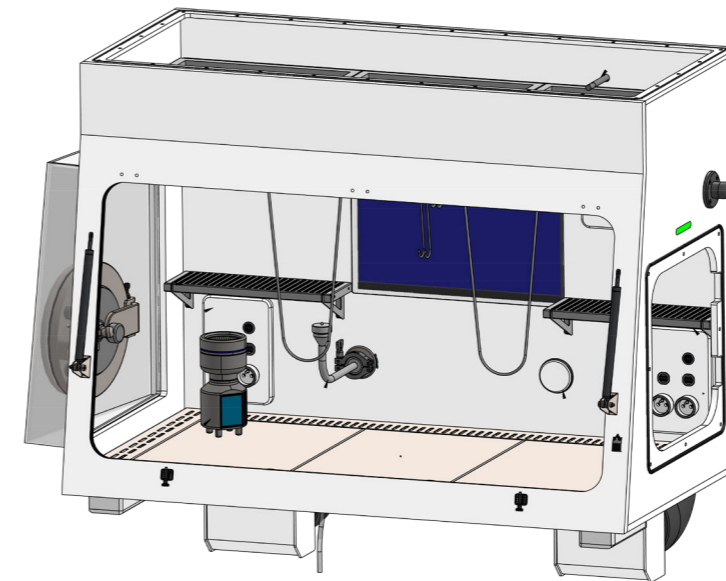

Integrated hydrogen peroxide bio-decontamination device Isosté H+.

Dynamic aeration and a 20-minute bio-decontamination cycle for the rapid airlock.

H14 HEPA filters on air intake and exhaust with 99.995% MPPS efficiency.

Benefits

Superior containment system to protect your product.

Flexible isolator to match your sterile/contained weighing and formulation activities.

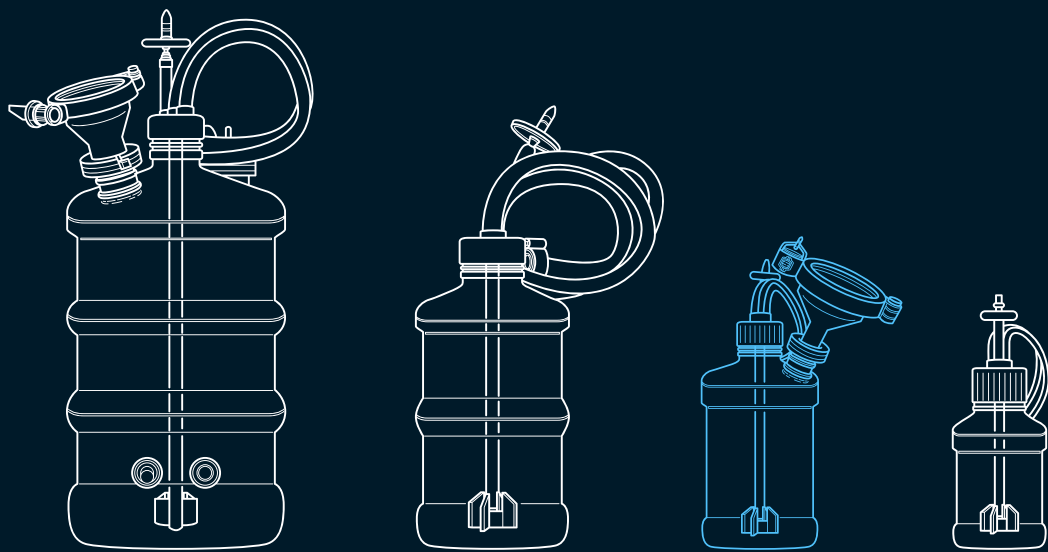

#WeRelease