



InstaPill®

A new paradigm in rapid dissolve tablets

Oral Lyophilisate Technology

Disappears in seconds

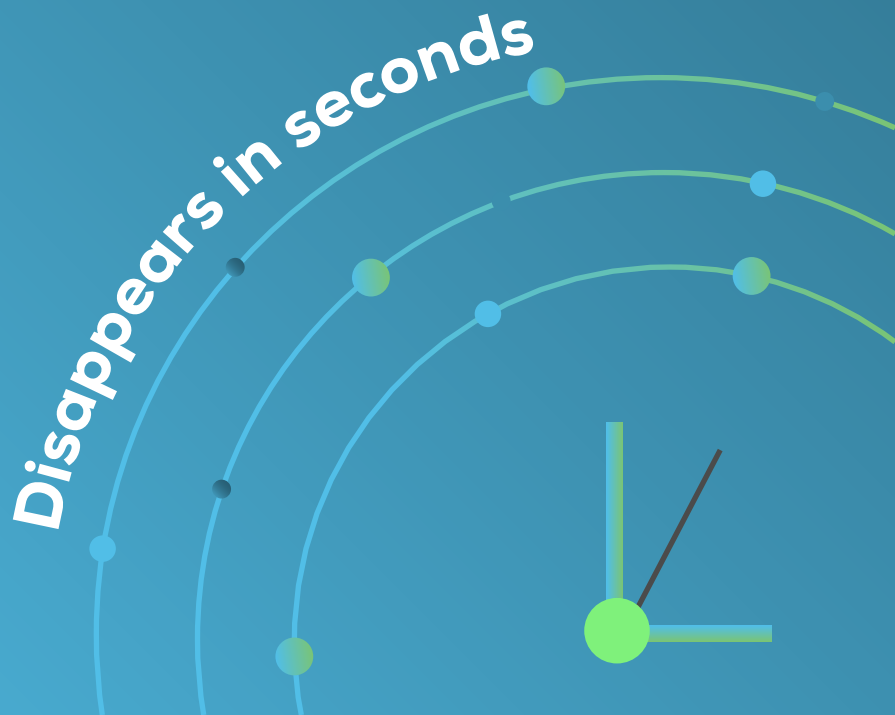

Driven by Technology

1 Blister forming & filling

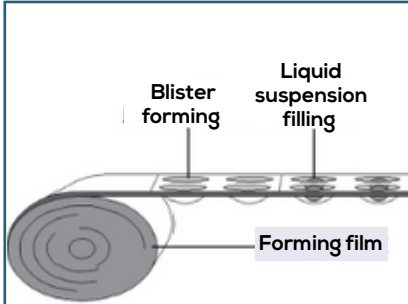

2 Freezing

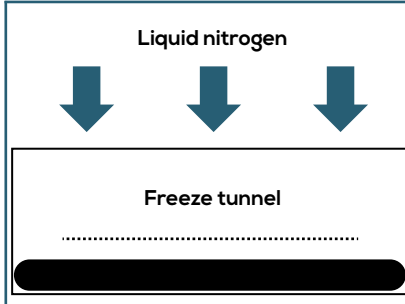

3 Lyophilization

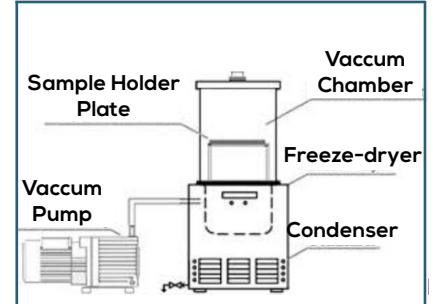

Automated Facility

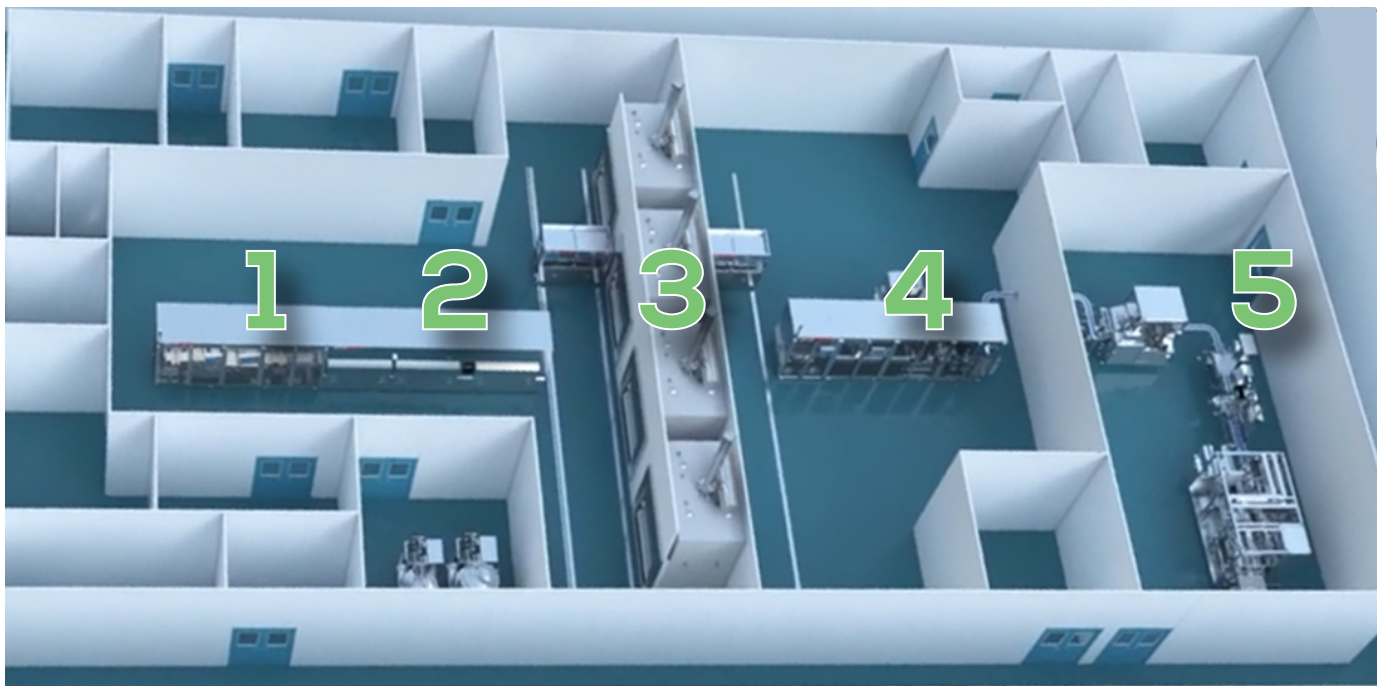

4 Primary Packaging

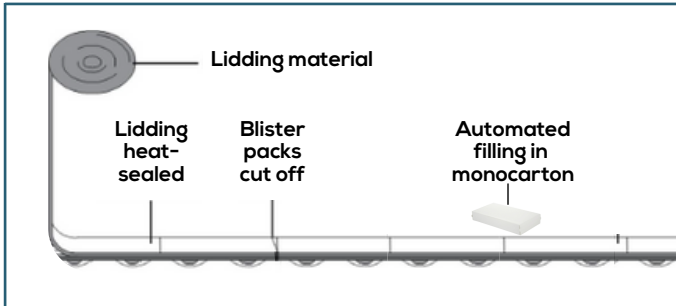

5 Secondary Packaging

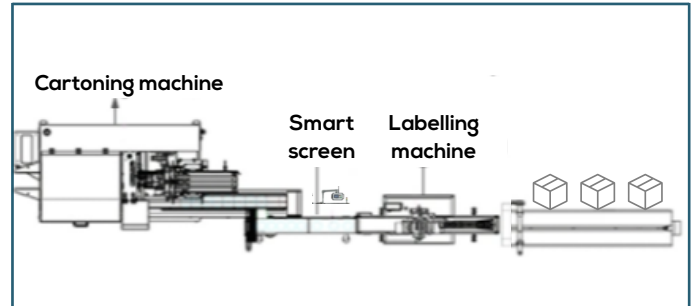

Advanced Manufacturing Science

Automation

Fully automated production line from dosing to shipper boxes with electronic batch records.



Control

Automated fill weight checks, blister pin-hole detection and vision system



Dose uniformity

High precision linear peristaltic pumps or positive displacement ceramic pump ensures dose uniformity



Safeguarding from contamination

No human handling of product and local air filtration (laf) to minimise risk.



State-of-the-Art Manufacturing Facility

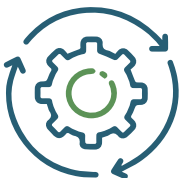

Fully integrated operation



Minimum human intervention

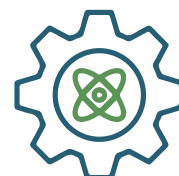

Large scale capacities



Future ready compliance

Unique Platform with Integrated Technology



Platform features

- Taste masking and superior dispersion
- Reduced numbers of excipients compared to conventional ODTs
- 100% Automation with digital documentation



Regulatory accreditations

- Manufacturing facility in Bangalore, India approved by USFDA, EMA, TGA & Health Canada



Development capabilities

- Full QbD (Quality by Design) approach from TPP (Target Product Profile) to validated approach
- R&D centre at Bangalore, India

Why InstaPill ?

Fully Automated Integrated line with **Electronic Batch Records**

No human intervention – for compliance & safety

Dissolves in **3-10 seconds**

0.06mg to 200mg dose range for customize portfolio

Ideal choice for **thermolabile products**

Taste masking & flavouring for better taste

We are also available in gelatin-free formulations

Registered office:

Plot No: 43, 44, 45 & 46,
KIADB Industrial Area, 1st Phase, Harohalli,
Ramanagara District, Karnataka - 562112

☎ +91 80 6784 0000 ✉ hello@insta-pill.com



www.insta-pill.com



InstaPill®