



The Leader in Pharmaceutical Printing, Laser Drilling & Vision Inspection Machinery

CO2 LASER DRILLING



21 CFR 1040.10
**CLASS 1
LASER
PRODUCT**

NIR OSMOTIC TABLET
INSPECTION

For Single & Bi-Layer Tablets, Caplets & LCT Products
Output Up to 60,000 Products / hour

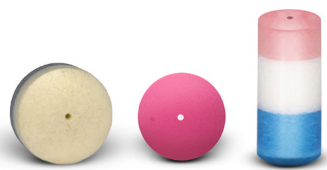

VIP Laser Drill + NIR

One or Two-Sided CO2 Laser Drilling Platform
Single-Lane Carrier Link Feed System

VIP Laser Drill + NIR

CO2 Laser Drilling for Tablets & LCT-Shaped Products

Precision laser machine designed to drill apertures in the outer coating of modified-release pharmaceutical products. Features a single-lane carrier timing belt feed system that exposes both sides of product for inspection and laser processing. Effortless continuous operation with minimal user interaction or downtime. Requires only compressed air and power for operation.

Features

- Single-lane carrier link system
- Safety enclosure with interlocked doors & enclosed beam path
- Servo based motion with optical encoder position feedback
- Carrier timing belt with precision machined pockets
- Tool-free installation of carrier links
- Adjustable hopper assembly for quick changeover between products
- Patented hopper air-assist feature & clean air filtration system
- Articulated swing arm with 17" touch-screen HMI
- User friendly interface
- Programmable settings for up to 50 products
- Portable with a small footprint
- Low maintenance cost
- Worldwide customer support
- Fume extraction unit & toolkit included

Capabilities

- Output Up to 60,000 / Hour
- Single or Double Sided Laser Drilling.
- Adjustable aperture:
 - Diameter - 0.400 to 1.500mm
 - Depth - 0.30 to 1.50mm
- Drill up to 4 apertures per side with adjustable spacing
- Color recognition system

Options

- Vision inspection with vacuum-based single product rejection
- NIR spectroscopy to verify integrity of membrane coating
- OPC-UA Server Gateway
- HMI screen text translated and displayed in language of choice
- Secure remote support capabilities
- Auto-backup of product settings

Safety & Regulatory Compliance

- **cGMP for Pharmaceuticals:**
- **FDA 21 CFR Compliance:**
 - Part 210
 - Part 211
 - Part 11
 - Part 1040: Class 1 Laser System
- **CE Compliant**
- **NFPA 79**
- **IEC 60825-1**
- **IEC / EN 60204-1**
- **ISO 13849-1**
- **CRC, c 870**
- **CDRH Compliant**

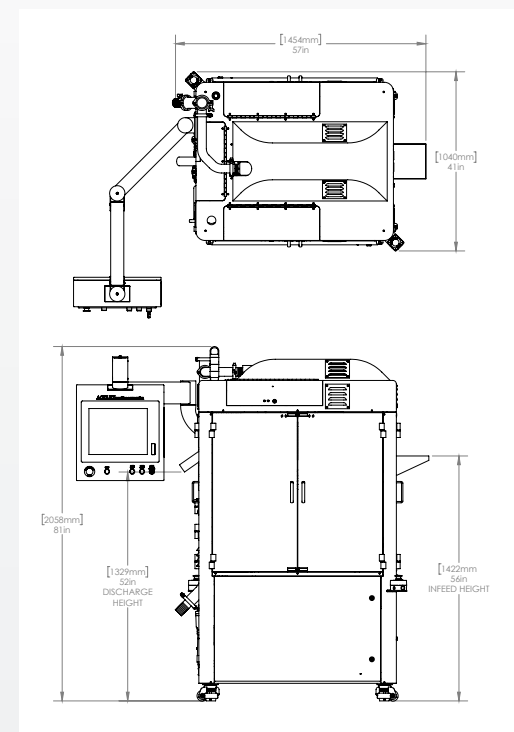

Specifications

Machine Dimensions:

Height 81" (2057 mm) x Width 58" (1473 mm) x Depth 41" (1041 mm)

Infed Height: 56" (1422 mm)

Discharge Height: 52.4" (1331 mm)

Weight: 2050 Lbs. (930 kg)

Power Requirement:

208-240 VAC / 50-60 Hz /

1 Phase, 25 Amp

Compressed Air:

85 PSI (6 Bar) @ 45 sCFM (76.5 m3/hr.)



Proudly Made in the USA