



MEDICAL &
INDUSTRIES



DISCOVER
OUR PRODUCT RANGE



TABLE OF CONTENTS

Bemis Medical & Industries 4	Customization Options 23
History and production site in France	Colors, textures, logos
ISO Certifications	Differences between Morpho and Monarch ranges
Bemis Manufacturing 5	Project Management 24
Group overview	Custom product development
Bemis Health Care division	Technical support
Innovation Process 6	Design and Industrial 25
Project support	Industrial design
Materials and customization	Medical devices (orthopedics, biological analysis, surgery)
Syringe Know-How 7	
Know-how	
Services and customization	
Bi-Material Range – Morpho 10 - 15	
Ergonomics and design	
Customizable colors and textures	
Technical information	
Mono-Material Range – Monarch ... 16 - 21	
Simplicity and efficiency	
Available colors	
Technical information	
Green Line – Recycled Material 22	
Accessories made from recycled materials	
Environmental commitment	



A FRENCH SITE BASED NEXT TO GRENOBLE

BEMIS MEDICAL & INDUSTRIES

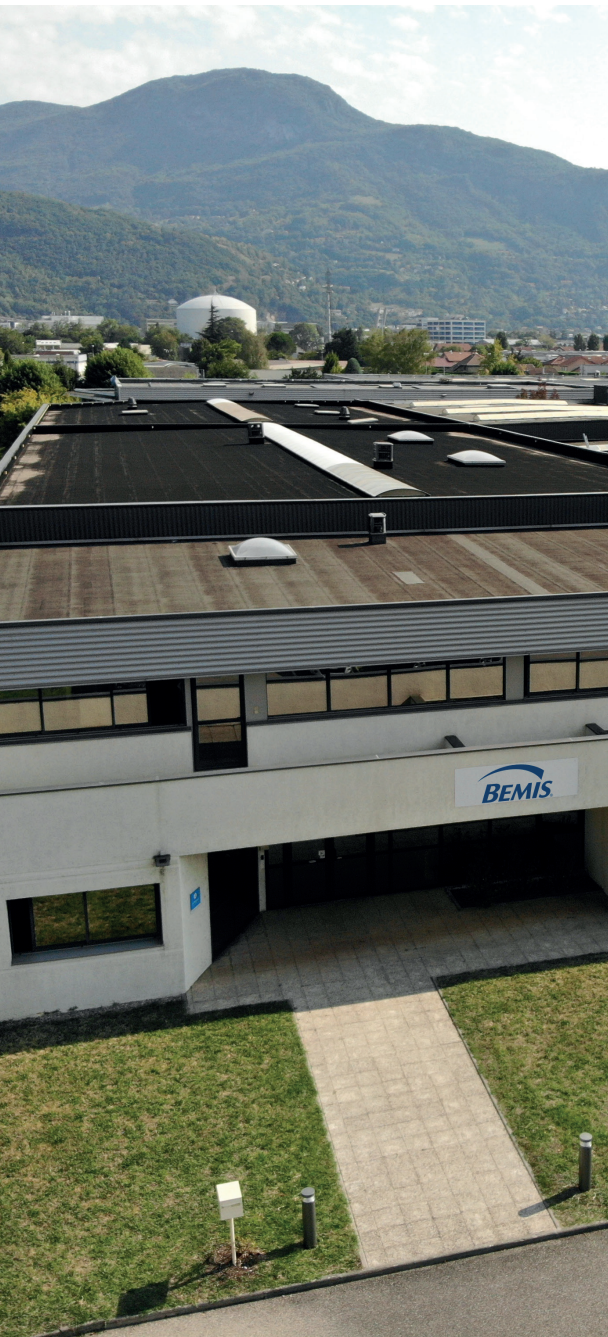

Privously named Dubourgel, Bemis SAS has been founded in 1945, and has been a pioneer in many fields. In 1988, Gérard Dubourgel designed the first syringe tub for the company Becton Dickinson which subsequently became an international benchmark. In 1989, Bemis built a cleanroom dedicated to the manufacturing of medical products, the first in the Rhône-Alpes region. This was followed by the launch of a finger flange and plunger rod range for our own brand for cosmetics and medical industries. More recently in 2008, Bemis designed the first Bi-Material syringe which was presented at the Pharmapack trade fair at the beginning of 2010. This syringe offers real possibilities for differentiation and facilitates the injection of viscous products. In 2017, Bemis launched the industrial production of bi-material finger and plungers for the global leader in cosmetics, Allergan.

In an environment of ever increasing restrictions and regulations, as well as a concern of supporting customers, Bemis is certified :

ISO 13485 «Design, development and industrialization of plastic parts for the pharmaceutical and medical sectors».

As well as ISO9001: 2015, «Design, manufacture and sale of innovative technical parts or assemblies in plastic materials intended for various sectors of activity including the sanitary, pharmaceutical and medical industries (clean room production)».

Since 2016, Dubourgel has been a subsidiary of Bemis Manufacturing (USA). Bemis holds a privileged position in the market thanks to its three production sites located in France, the USA, and Mexico.

SUPPORTED BY A WORLDWIDE COMPANY

BEMIS MANUFACTURING

Bemis Manufacturing Company is a family-owned business established in 1901. Headquartered in Sheboygan Falls, Wisconsin, U.S.A., they have grown to an innovative, international manufacturer serving worldwide markets.

We manufacture products under our own brands and provide expertise to others, including private-label products and component parts for a variety of industries. We serve consumer, commercial, medical and industrial markets worldwide and have over 2 000 employees located in five countries around the world.

Innovation is the cornerstone on which Bemis Manufacturing Company was built. Building on this foundation, we have grown into a global leader, delivering innovative concepts, processes, and products, supported by over 250 active and pending design and process patents.



BEMIS HEALTH CARE™

Founded in 1971, Bemis Health Care has become a world class medical device plastics molding company with a reputation for state-of-the-art technology, quality products and excellent customer service. Our focus is providing products that safely and efficiently collect bodily fluid, sharps, and other specialty medical waste types.



**HEALTH
CARE**

Bemis Health Care is a division of Bemis Mfg. Co., the world's largest manufacturer of toilet seats, serving residential, commercial and OEM industries. Bemis Contract Group, another division of Bemis Mfg. Co., provides plastic components and custom product solutions to a wide variety of industries. Founded in 1901, Bemis continues to be privately owned and operated. Headquartered in Sheboygan Falls, Wisconsin, Bemis has worldwide distribution in North, Central and South Americas, Europe and Asia Pacific.

PROJECT CREATION TO FOLLOW YOUR INNOVATION PROCESS *

Syringe body material
Glass / COC / COP

Size available
1 ml, 2 ml, 3 ml, 10 ml
5 ml on request

Color available
Custom colors on regular and soft touch.

From syringe accessories to industrial projects, we are here to assist you. Bring us your ideas, and we will turn them into a reality. Our support extends from the initial product concept stage, including design, advice on selecting the right raw materials for your project, 3D design, 3D printing of a sample, to production support and actual manufacturing.

Additionally, we offer assistance in preparing your regulatory files. We have extensive experience working with laboratories and medical companies, helping them through the process of completing meticulous documentation to meet the stringent requirements of their respective fields.

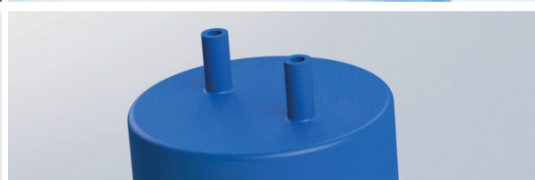
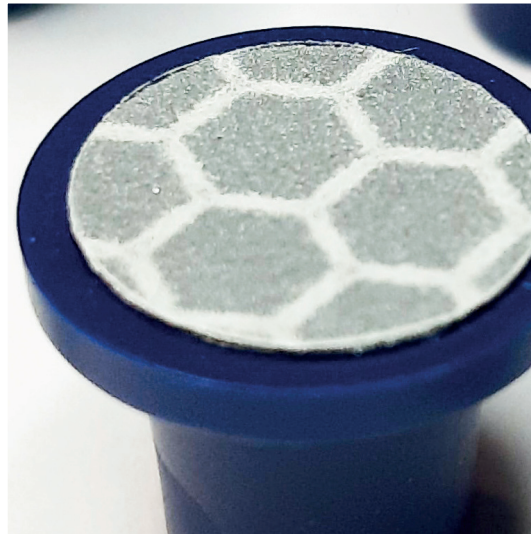
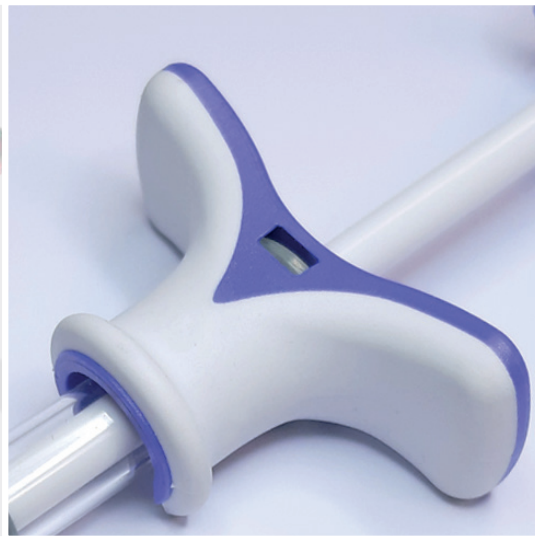



TAKE ADVANTAGE OF OUR SYRINGE KNOW-HOW

Our production facilities at your service

Dubourgel Medical is well-known for its expertise in syringe accessories, but our primary strength lies in our knowledge of injectable components. We provide consulting services for your project, helping you understand how our raw materials can meet your product performance requirements. With experience collaborating with various companies across diverse medical fields, we possess a deep understanding of the sector's expectations and the constraint involved in bringing a product like yours to market.

Our services cover from design to production in ISO 7 cleanrooms, encompassing mold production, product development, creation of manufacturing instructions, and implementation of quality control processes.

Furthermore, we offer our own product range for glass, COP and COC syringes, eliminating the need for customers to invest in molds and peripheral equipment.

Additionally, we provide a broad spectrum of customization options, including a wide range of colors, translucent or plain finishes, branding, logo integration, stamping under certain conditions, and various packaging choices.

We know and understand your market

We collaborate with renowned leaders in the fields of aesthetics and the medical sector, establishing trusted partnerships with top-tier brands. Our customers commitment is to continually challenge ourselves to devise solutions that enhance the comfort and efficiency of your clients.

We remain constantly vigilant to market developments, conducting in-depth studies to gain a thorough understanding of your industry. Our goal goes beyond merely fulfilling the requirements outlined in a specification document, as we aspire to a genuine comprehension of your market.

We are proud to announce that esteemed laboratories such as Teoxanes and Fillmed have already placed their trust in our expertise. This recognition attests to our dedication to excellence and our ability to meet the highest industry standards.

BUILT FOR COMFORT

Our bi-material syringe accessories are engineered to enhance handling and reduce fatigue giving practitioners better control and a more ergonomic experience with every injection.



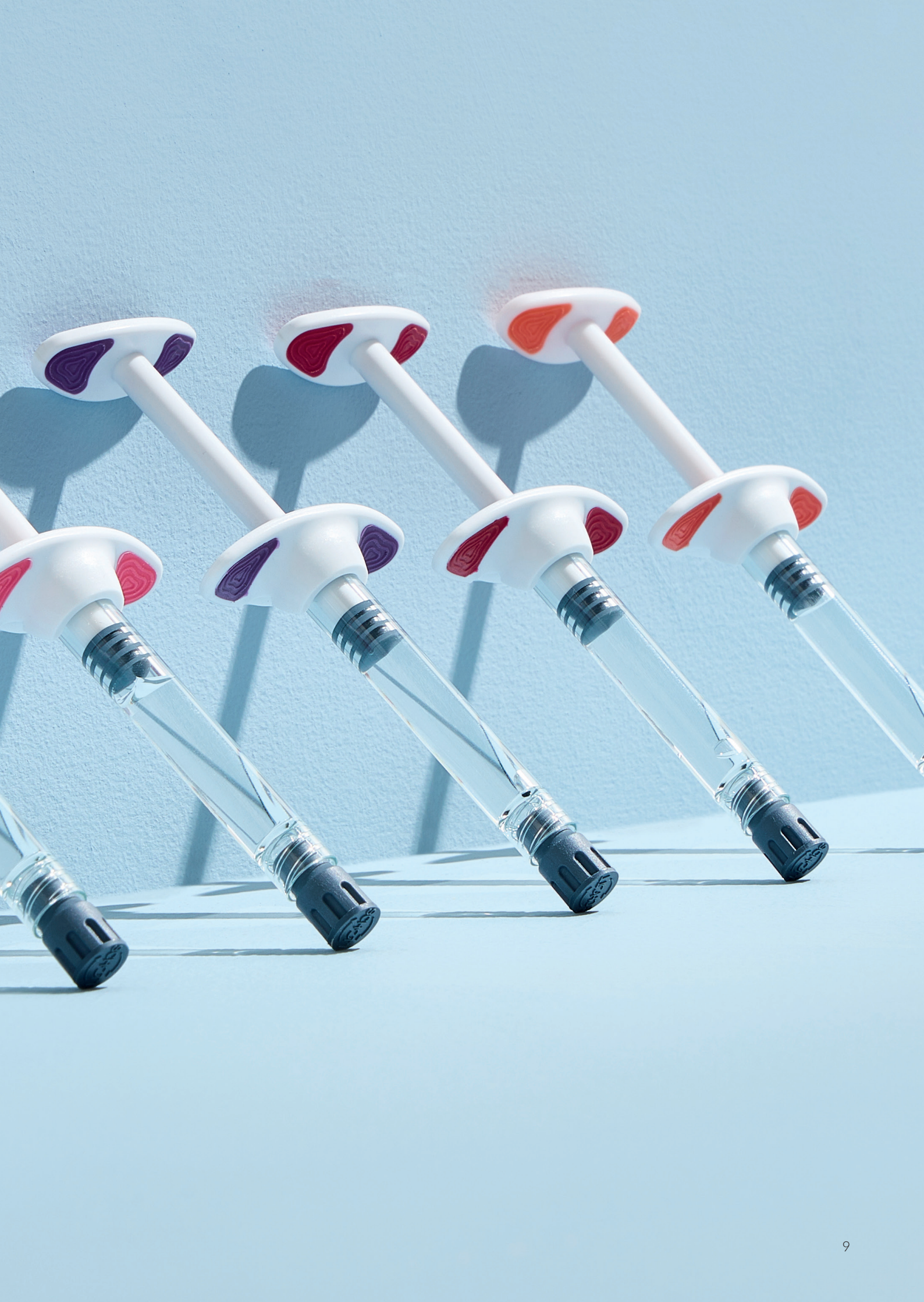

ELEGANCE AT THE SERVICE OF PROFESSIONALS

MORPHO RANGE

Inspired by the Morpho butterfly, a symbol of color, agility, and transformation, our new range of syringe accessories embodies an innovative vision of comfort and performance.

Morpho is more than just a name, it's a promise.

A range designed for aesthetic medicine professionals, combining ergonomics, versatility, and vibrant design. Each accessory is crafted to support the daily work of aesthetic surgeons, while bringing a touch of modernity to their practice.

Just like the butterfly it's named after, the Morpho range stands out through:

- Good maneuverability, for optimal everyday comfort
 - Modular design, adaptable to the specific needs of each practice
 - Bright, distinctive colors, for easy identification
- Morpho transforms the user experience, blending style and efficiency.

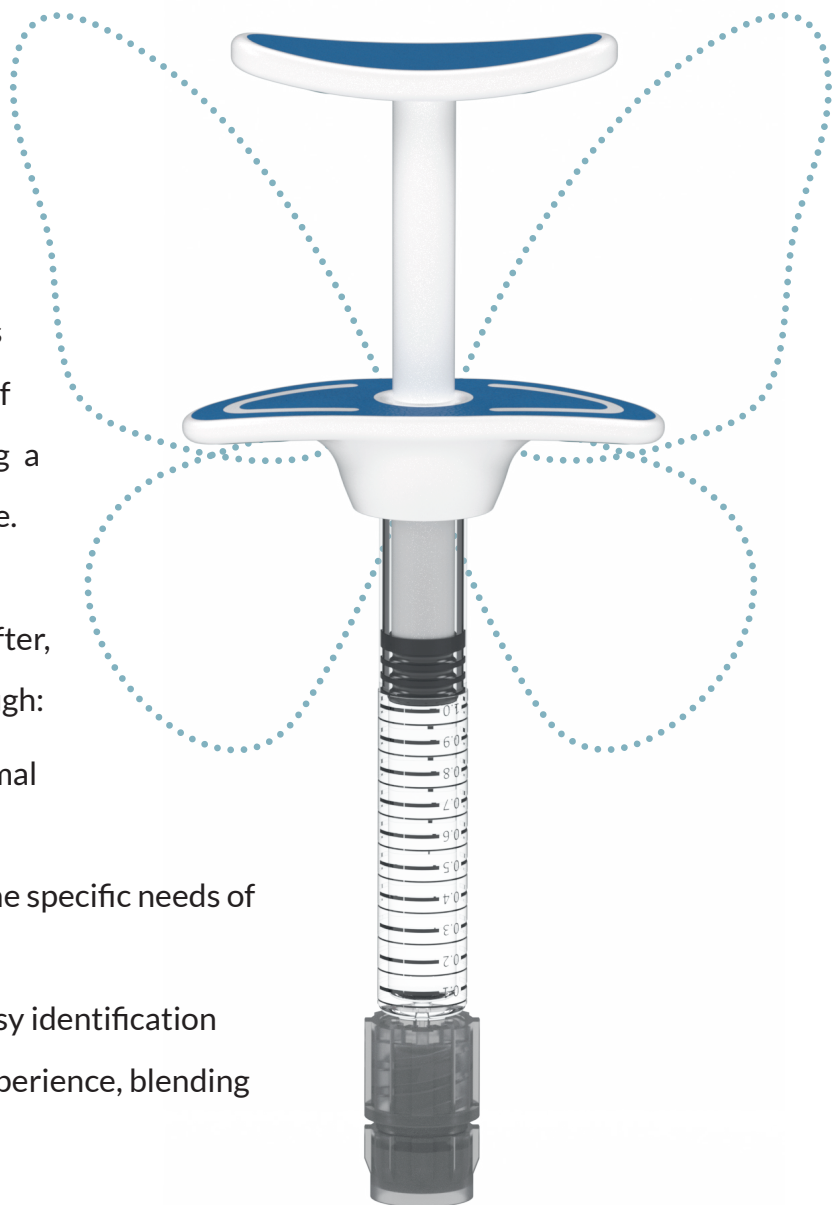

MORPHO RANGE

THE READY-TO-USE SOLUTION

Monarch
Mono-material

Morpho
Bi-material

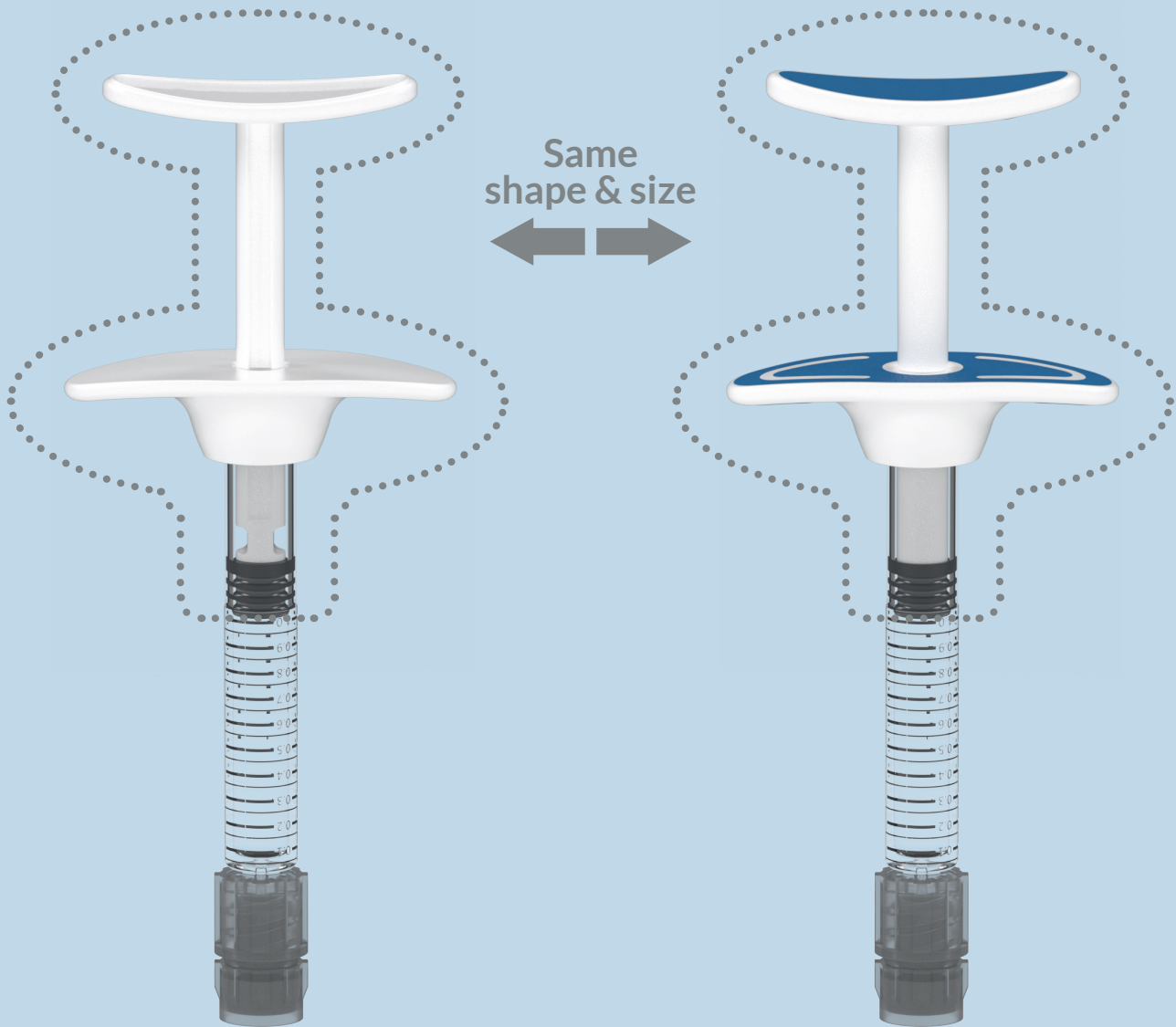

This solution allows you to get started with reliable equipment that perfectly meets practitioners' expectations. If you've been used to working with our Monarch range (mono-material accessories), this new range is designed to maintain the exact same shape, ensuring compatibility with your current packaging.

MORPHO RANGE

CHOOSE YOUR COLORS

A range of colors is available and ready for use. Create your range based on our collection or share your color codes with us, enabling us to align them more closely with your brand guidelines.

Rigid part white for better readability with a higher contrast with the graduation labels. And a softer colored.

Color customization available on quotation.



1. LIGHT PINK
2. PINK
3. RED
4. LIGHT GREEN
5. TURQUOISE
6. BLUE
7. GREY
8. BLACK
9. PURPLE

MORPHO RANGE

PICK OR CREATE YOUR OWN

Customize the textures

You can choose to use the standard textures that are offered and designed to suit professionals during their procedures. Alternatively, you can create a customized texture based on your own preferences.

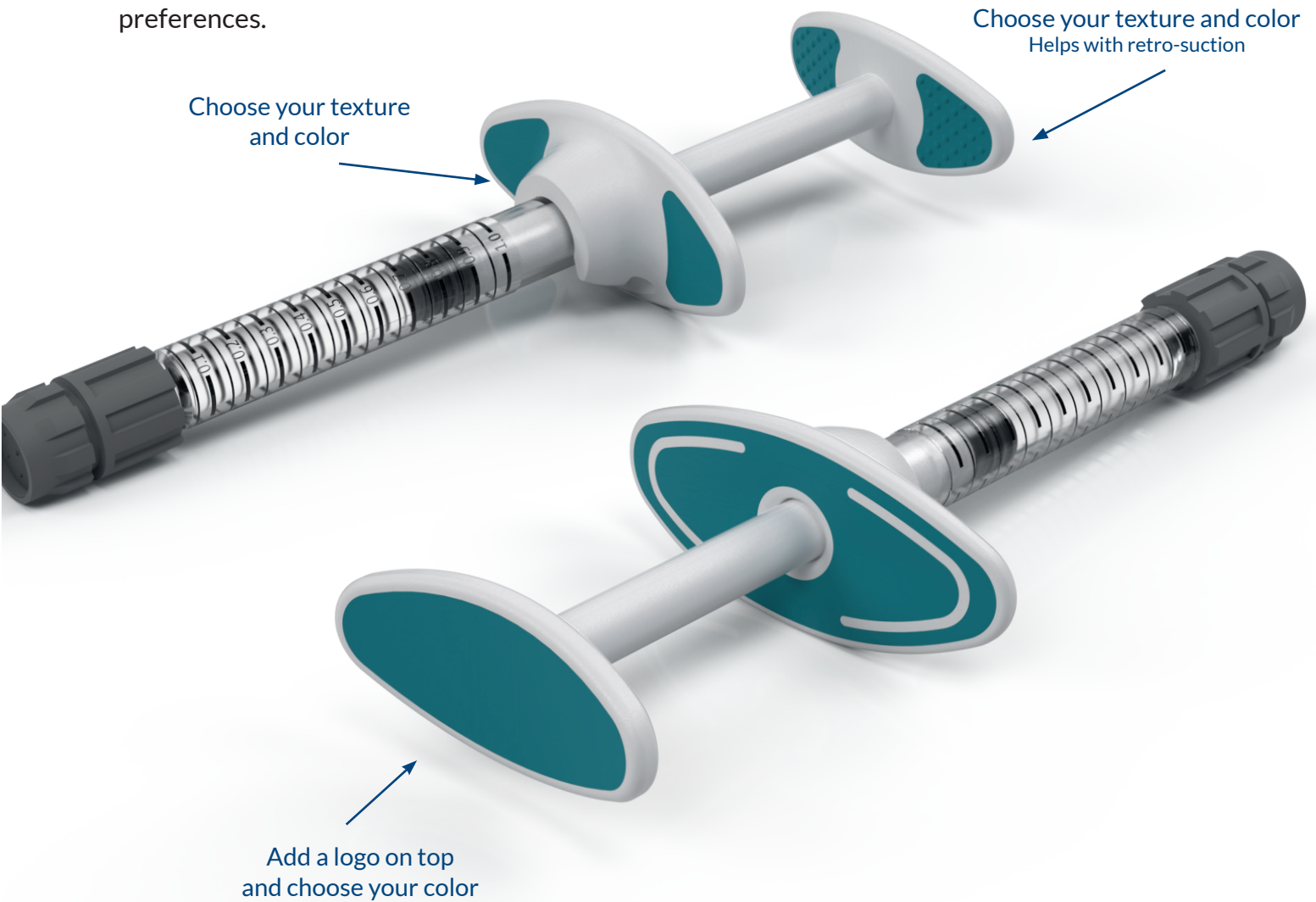

Customize the top

You have the flexibility to tailor the upper section with your logo or personalized text. Feel free to make it uniquely yours or leave it empty.

MORPHO RANGE

TECHNICAL INFORMATIONS

FINGER

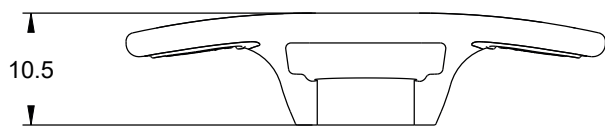

Opened version

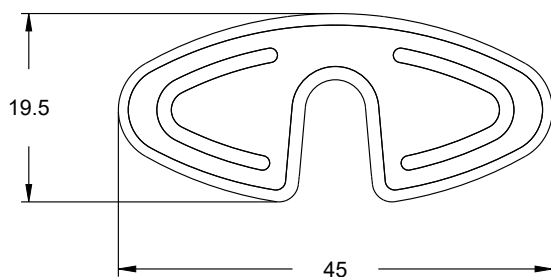

Closed version

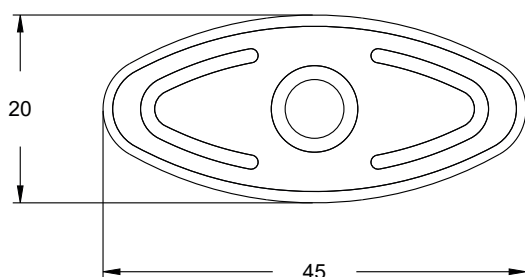

PLUNGER

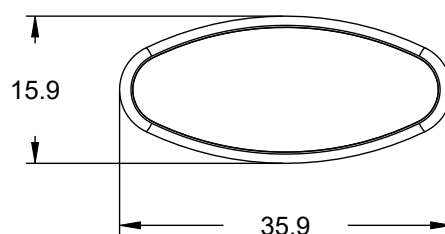
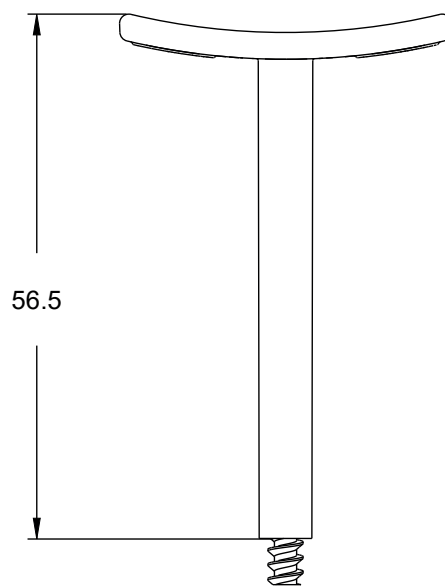

** all dimensions in mm*

Batches

400 parts per bag
 4 800 fingers per carton
 153 600 per pallet
 2 400 plungers per carton
 76 800 per pallet

Rigid Raw Material

PC Makrolon 2458
 PETG R200 on request

Soft Raw Material

SEBS Cawiton

Syringes Compatibility

Glass or COC/COP long
 Extra-long on request

Size



1 ml

Finger available closed or open

**accurate details on request*

BI-MATERIAL SYRINGE ACCESSORIES

MORPHO RANGE

IMAGE	DESIGNATION	SYRINGE MATERIAL	PLASTIC MATERIAL *	STOPPER FIXATION TYPE	PACKAGING UNIT	REFERENCE <small>(black color)</small>
	CLOSED FINGER 1 ml	Glass	Medical grade	-	4800	DBM1FI0MKNOIR
		COC	Medical grade	-	4800	DBM1FI1MKNOIR
	OPENNED FINGER 1 ml	Glass	Medical grade	-	4800	DBM1FO0MKNOIR
		COC	Medical grade	-	4800	DBM1FO1MKNOIR
	PLUNGER ROD 1 ml **	Same shapes for Glass, COC, COP Syringes	Medical grade	Screw designed for glass and COC syringe type	2400	DBM1TI0MKNOIR

* conscious material available on quotation

** different length on quotation

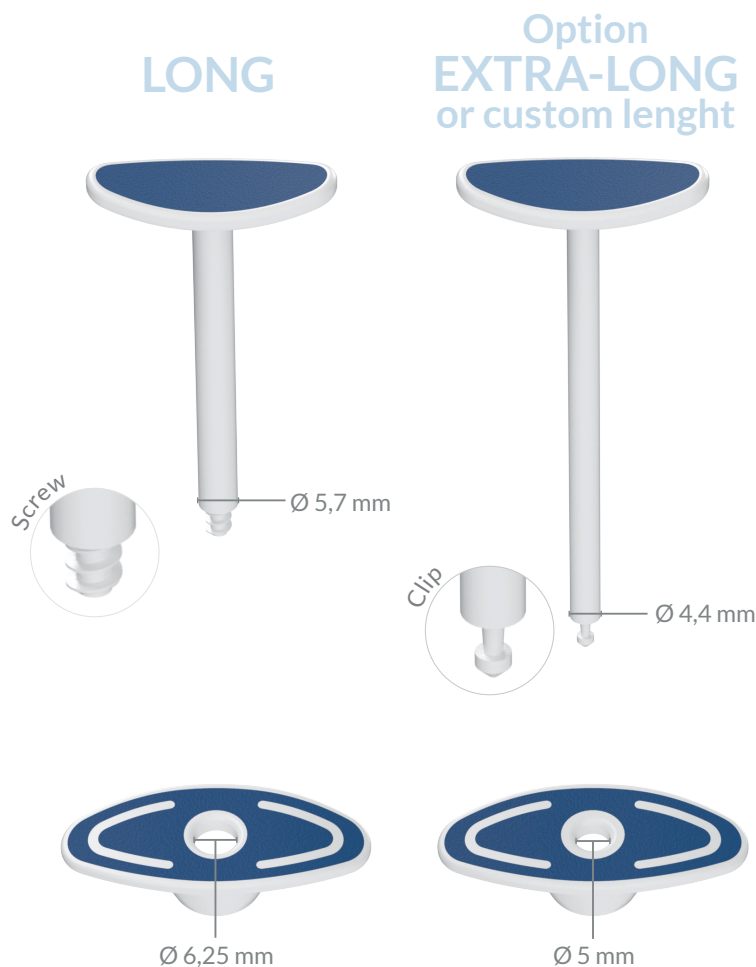

Length

Designed to fit long syringes. Custom Lengths, for extra-long or specific dimensions, custom development is available upon request.

Stopper Connection

The connection shape between the plunger rod and the stopper can be customized to your needs.

Plunger Diameter & Finger Hole

Both the diameter of the plunger and the design of the finger hole can be customized for optimal ergonomics and compatibility.

DESIGNED FOR EFFICIENCY

Our mono-material syringe accessory is designed to meet the essential needs of healthcare professionals. With its refined shape and a variety of colors, this range is ideal for entering new markets or attracting budget-conscious customers.





PURE FUNCTION, NATURAL PRECISION

MONARCH RANGE

Monarch takes its name from the iconic butterfly, celebrated for its graceful transformation and precise flight.

Like the butterfly, our single-material syringe reflects a refined and functional design, focused on what truly matters.

Built from a single material, the syringe is engineered to be both dependable and durable. This simplicity mirrors the Monarch's natural efficiency, a structure that enables long journeys with minimal complexity.

The collection was developed to meet the essential needs of healthcare professionals. It combines functional design with intuitive handling and consistent quality, supporting routine procedures with ease and precision.

Just as the Monarch adapts to its environment with elegance and clarity, our syringe is designed to respond to everyday demands with confidence and fluidity.

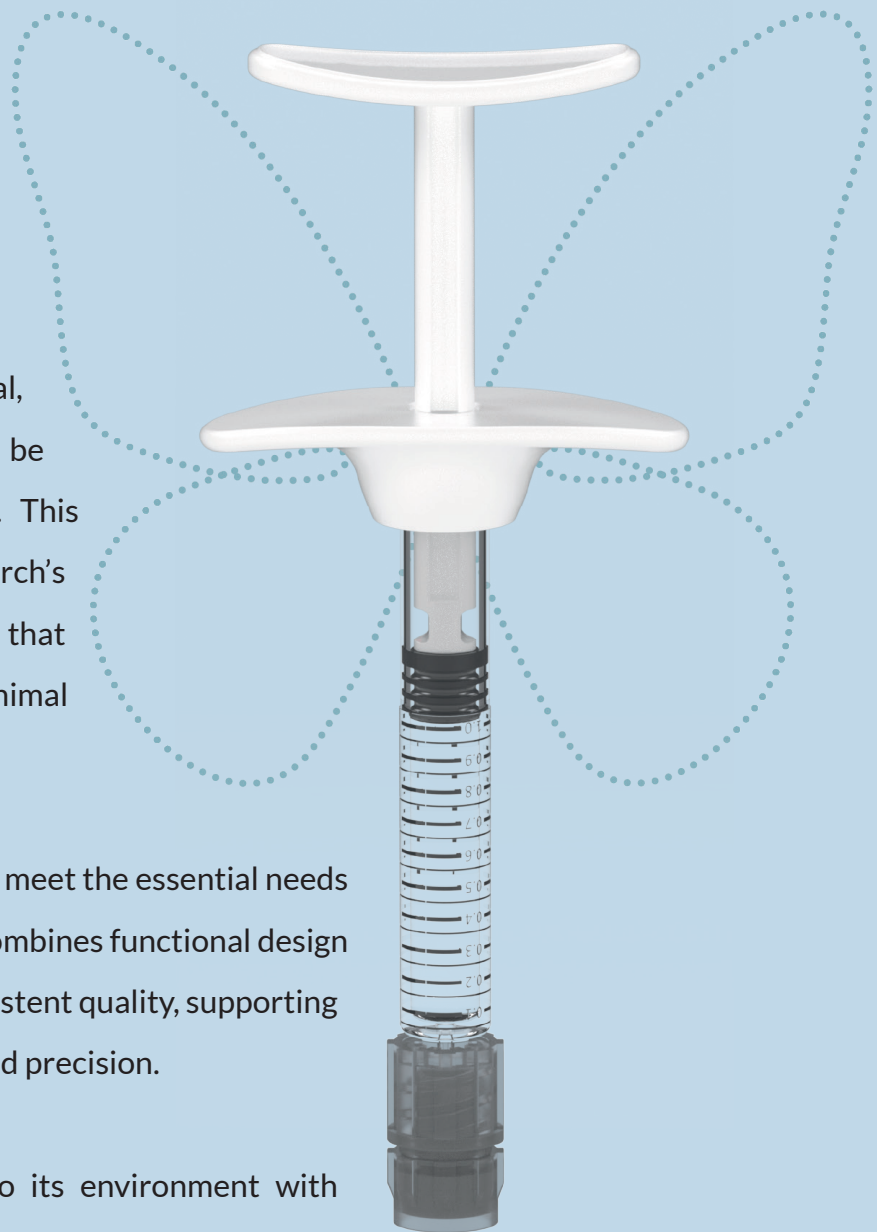

MORPHO RANGE

CHOOSE YOUR COLORS

A range of colors is available and ready for use. Create your range based on our collection or share your color codes with us, enabling us to align them more closely with your brand guidelines.

Color customization available on quotation.



- 1. WHITE
- 2. TRANSPARENT
- 3. LIGHT PINK
- 4. PINK
- 5. RED
- 6. PURPLE
- 7. LIGHT GREEN
- 8. TURQUOISE
- 9. BLUE
- 10. GREY
- 11. BLACK

MONARCH RANGE

TECHNICAL INFORMATIONS

FINGER

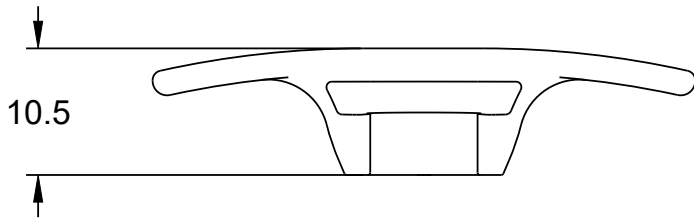

Opened version

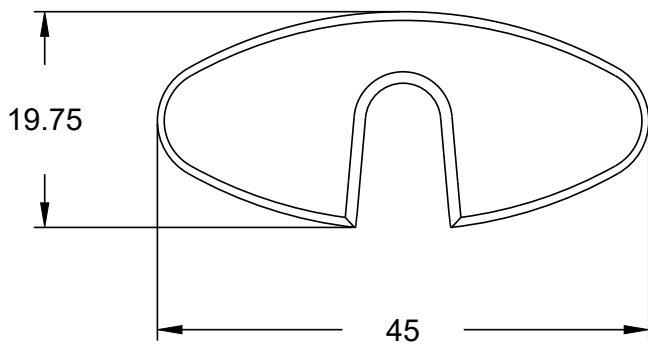

Closed version

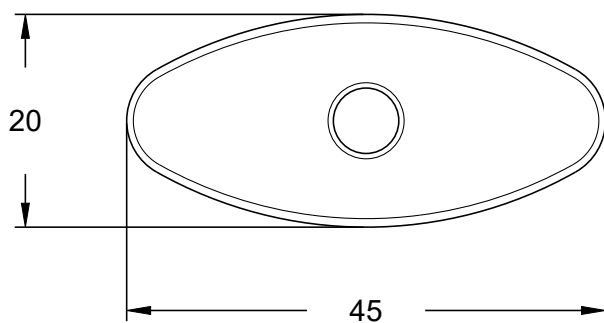

PLUNGER

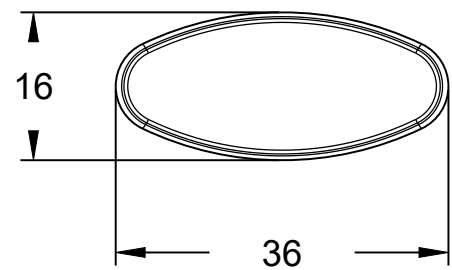
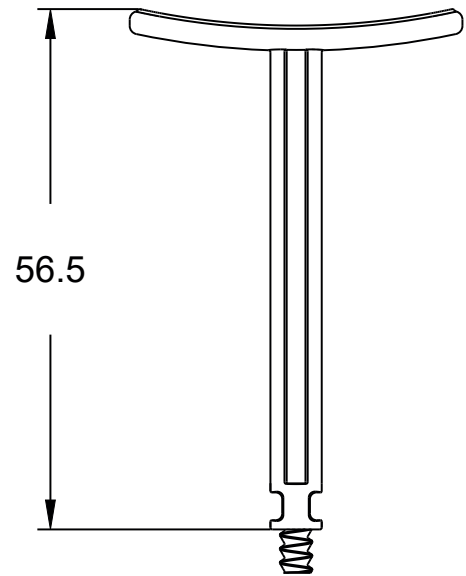

* all dimensions in mm

Batches

400 parts per bag
 4 800 fingers per carton
 153 600 per pallet
 2 400 plungers per carton
 76 800 per pallet

Rigid Raw Material

PC Makrolon 2458 (medical grade which can be sterilized)
 or Makrolon 2405 (Standard grade which replace Calibre 303 EP)
 10 ml only available with Makrolon 2458

Syringes Compatibility

Glass or COC/COP
 long version only

Size













1 ml / 2 ml / 3 ml / 10 ml
 5 ml on request

Finger available closed or open

**accurate details on request*

MONOMATERIAL SYRINGE ACCESSORIES

MONARCH RANGE

IMAGE	DESIGNATION	SYRINGE MATERIAL	PLASTIC MATERIAL ***	STOPPER FIXATION TYPE	PACKAGING UNIT	REFERENCE <small>(natural translucent color)</small>
	CLOSED FINGER 1 ml	Glass	Non-medical grade PC	-	4800	D1F10NAT
		Glass	Medical grade	-	4800	D1F10MKNAT
		COC	Non-medical grade PC	-	4800	D1F11NAT
		COC	Medical grade	-	4800	D1F11MKNAT
	OPENNED FINGER 1 ml	Glass	Non-medical grade PC	-	4800	D1F00NAT
		Glass	Medical grade	-	4800	D1F00MKNAT
		COC	Non-medical grade PC	-	4800	D1F01NAT
		COC	Medical grade	-	4800	D1F01MKNAT
	PLUNGER ROD 1 ml	Same shapes for Glass, COC, COP Syringes	Non-medical grade PC	Screw designed for glass and COC syringe type	2400	D1T10NAT
			Medical grade		2400	D1T10MKNAT
			Non-medical grade PC	Screw designed for COP syringe type*	2400	D1T11NAT
			Medical grade		2400	D1T11MKNAT
	CLOSED FINGER 2 ml et 3 ml	Glass	Non-medical grade PC	-	3200	D3F10NAT
		Glass	Medical grade	-	3200	D3F10MKNAT
		COC	Non-medical grade PC	-	3200	D3F11NAT
		COC	Medical grade	-	3200	D3F11MKNAT
	OPENNED FINGER 2 ml et 3 ml	Glass	Non-medical grade PC	-	3200	D3F00NAT
		Glass	Medical grade	-	3200	D3F00MKNAT
		COC	Non-medical grade PC	-	3200	D3F01NAT
		COC	Medical grade	-	3200	D3F01MKNAT
	PLUNGER ROD 2 ml	same design for Glass or COC Syringes	Non-medical grade PC	Screw	1600	D2T10NAT
			Medical grade	Screw	1600	D2T10MKNAT
	PLUNGER ROD 3 ml	same design for Glass or COC Syringes	Non-medical grade PC	Screw	1600	D3T10NAT
			Medical grade	Screw	1600	D3T10MKNAT
	**CLOSED FINGER 5 ml	Glass	Non-medical grade PC	-	** TBD	D5F10NAT
		Glass	Medical grade	-	** TBD	D5F10MKNAT
		COC	Non-medical grade PC	-	** TBD	D5F11NAT
		COC	Medical grade	-	** TBD	D5F11MKNAT
	**OPENNED FINGER 5 ml	Glass	Non-medical grade PC	-	** TBD	D5F00NAT
		Glass	Medical grade	-	** TBD	D5F00MKNAT
		COC	Non-medical grade PC	-	** TBD	D5F01NAT
		COC	Medical grade	-	** TBD	D5F01MKNAT
	*PLUNGER ROD 5 ml	same design for Glass or COC Syringes	Non-medical grade PC	Screw	** TBD	D5T10NAT
			Medical grade	Screw	** TBD	D5T10MKNAT
	CLOSED FINGER 10 ml	Glass	Non-medical grade PC	-	** TBD	D10F10NAT
		Glass	Medical grade	-	** TBD	D10F10MKNAT
		COC	Non-medical grade PC	-	** TBD	D10F11NAT
		COC	Medical grade	-	** TBD	D10F11MKNAT
	**OPENNED FINGER 10 ml	Glass	Non-medical grade PC	-	** TBD	D10F00NAT
		Glass	Medical grade	-	** TBD	D10F00MKNAT
		COC	Non-medical grade PC	-	** TBD	D10F01NAT
		COC	Medical grade	-	** TBD	D10F01MKNAT
	PLUNGER ROD 10 ml	same design for Glass or COC Syringes	Non-medical grade PC	Screw	** TBD	D10T10NAT
			Medical grade	Screw	** TBD	D10T10MKNAT

* available in 2024

** on request

*** conscious material available on quotation

SYRINGE ACCESSORIES GREEN LINE

Recycled material?

The material we use comes from the mechanical recycling of plastic bottles.

Once mechanically regrinded, the material is mixed with virgin material and extruded to form granules.

With this process, we are able to re-inject the material and manufacture the Green Line

Like you, we are aware of the current environmental challenges issues.

We are committed to developing products that are more respectful of the planet.

Because everyone can make a difference, we offer an extension to our standard range.



Product made WITH 30% recycled material

For this product under development, please contact us.



High precision of the surgical gesture

Certifications
ISO 13485 : 2016
ISO 9001 : 2015

Product performance similar to the standard range.

Two versions are available for syringes in glass or plastic COC/COP.

Optimization of the scrap rate.

Reduced environmental impact : circular economy supported

30% recycled material.

Color range inspired by nature



RANGES OVERVIEW

CUSTOMIZATION OPTIONS

Customization That Reflects Your Identity

At Bemis, we offer customization options to help your products align perfectly with your brand and operational needs.

	Monarch	Morpho
Type	Mono-Material	Bi-Material
Color	○	○
Logo	○	○
Texture	/	○
Extra-long syringe	/	○
Sustainable material	○	○
Separate colors Plunger and Finger	/	Yes, Up to 4 different colors per kit

Monarch Range

Focused on essential performance, the Monarch range offers simple and effective customization options:

- Custom color definition for trials, including pigment selection, validation plates, and injection testing.
- Logo integration on the thumb area of the plunger, with 3D modeling and realistic rendering for approval.

These features allow you to personalize your products while maintaining reliability and ease of use.

Morpho Range

For brands seeking a more distinctive and tactile experience, the Morpho range offers advanced customization possibilities:

- Dual-color customization for rigid and soft components.
- Custom textures on key contact areas, including the finger grip and the back suction zone of the plunger.
- Enhanced logo integration with dedicated inserts and detailed finishing.

Morpho is designed for those who want to combine ergonomics, aesthetics, and brand differentiation.

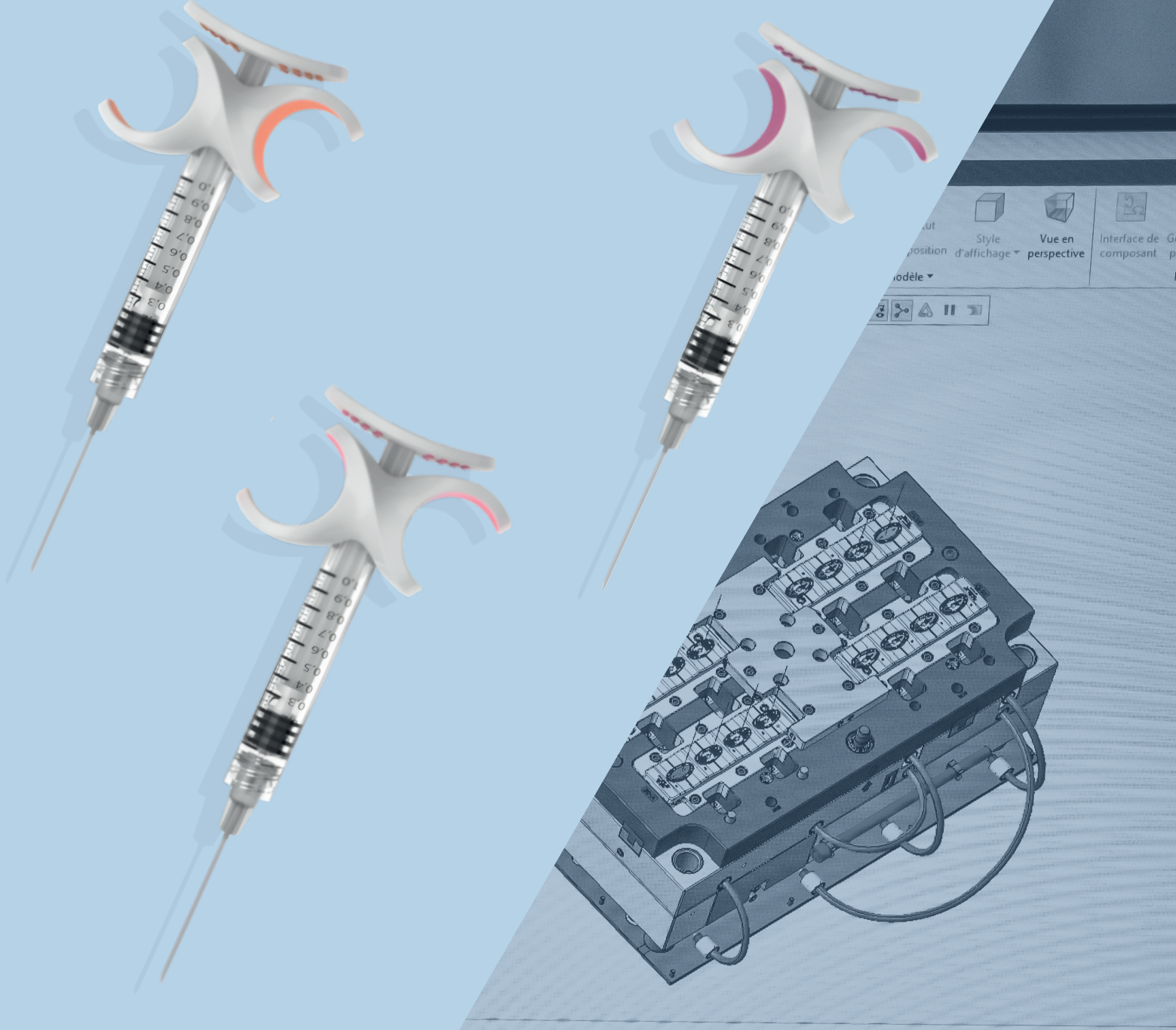

PROJECT MANAGEMENT

LET'S START FROM SCRATCH

A fully customizable syringe accessory is your key to standing out in the market. It empowers you to develop innovative technologies and introduce unique features that elevate your product offering.

We support companies that want to create their own style and strengthen their brand identity.

Connect with our team to explore what's possible.

OUR ADDITIONAL SKILLS DESIGN AND INDUSTRIAL

We use our expertise at all stages of the project to produce parts made from different materials, such as polycarbonate, polypropylene, ABS, or any other technical materials.

Dubourgel can help in the selection of the best material according to the constraints of the customer's product and support on the development of the compound, dye, or material.



*Designed by Bemis Medical & Industries
for high end 5 ml syringe*

OUR ADDITIONAL SKILLS

MEDICAL DEVICES

Dubourgel is a medical device specialist. We have the right skills and equipment to assist you in your projects, with two ISO 7 cleanrooms dedicated to the manufacturing of sterile products.

One cleanroom being particularly dedicated to the manufacturing of bi-material components.

We can also provide auxiliary services for injection molding, such as assembly, marking and molding.



Orthopedic markers for robotics surgical intervention

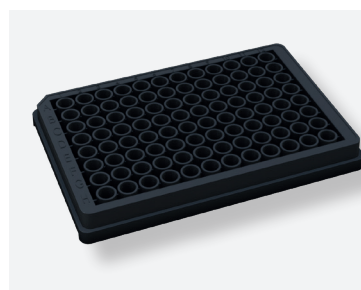

Blood and biological analysis

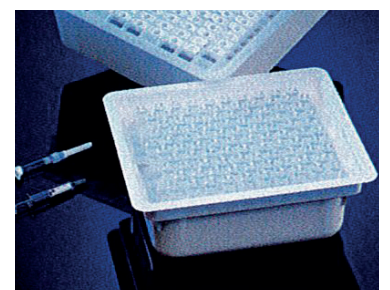

Tubs and nests



Hi-Flow™ Rigid Suction Canisters

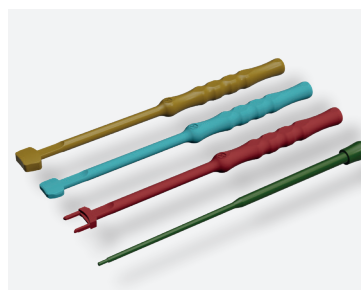

Surgical tools for spine surgery procedures



Surgical tools for hips replacement surgery procedures



MEDICAL &
INDUSTRIES

BEMIS SAS
11 rue d'arcelle
38 600 Fontaine
France

frsalesmi@bemismfg.com
bemis-medicalindustries.com

RCS 606220465 - APE 2229A

Édition 2 -
Catalogue Marketing Medical & Industries 2026