

# LCI Sanitary Super Labvap®

# Most Robust Lab Evaporator



## Perfect for Lab and R&D!

The LCI Sanitary Super LabVap® provides a means for you to evaluate thin-film evaporation technology using small quantities of your products in your own facilities. The LCI Sanitary Super LabVap® is designed as a screening and product development tool to evaluate a broad variety of applications.

This versatile tool provides a means for evaluating thin-film processing of your products in the early stages of product development within your own laboratories. Only small quantities of material are needed.

The Sanitary Super LabVap® can be used to evaluate a broad variety of applications. It can provide qualitative results that will help determine if thin-film qualitative results that will help determine if thin-evaporation technology is suitable for your needs.

## Lease or purchase today!

LCI's Sanitary Super Labvap® system provides an inexpensive means to evaluate thin film evaporation on lab-scale quantities of material for your development or existing products within your own facility.

## Customize Your Solution!

In addition to the thin-film evaporator, an LCI Sanitary Super Labvap® System can include any of these additional component options:

- Feed tank
- Feed metering pump
- Vapor condenser
- Vacuum system
- Wheeled cart
- Piping, valves, etc.
- Optional 3A Dairy stamp available



LCI Sanitary Super LabVap® on wheeled cart

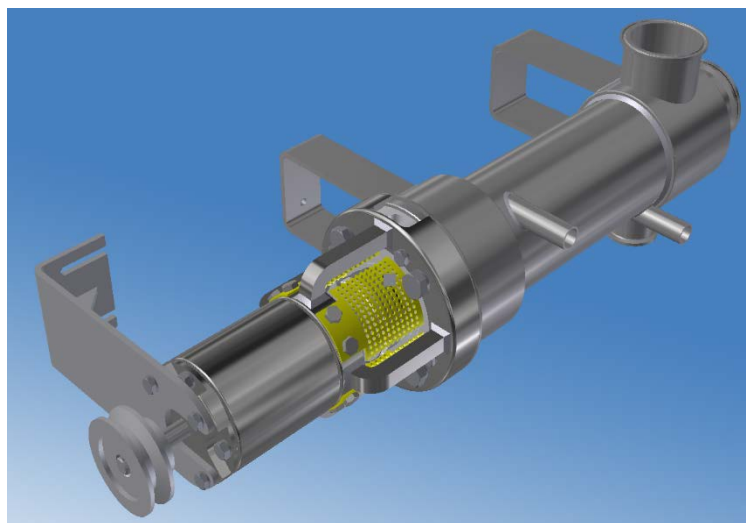

LCI Sanitary Super LabVap®

**Contact LCI to discuss your application and the benefits of the Sanitary Super Labvap® today!**



LCI Corporation  
4433 Chesapeake Drive  
Charlotte, NC 28216

704-394-8341  
Email [info@lccorp.com](mailto:info@lccorp.com)  
[www.lccorp.com](http://www.lccorp.com)

# LCI Sanitary Super LabVap®

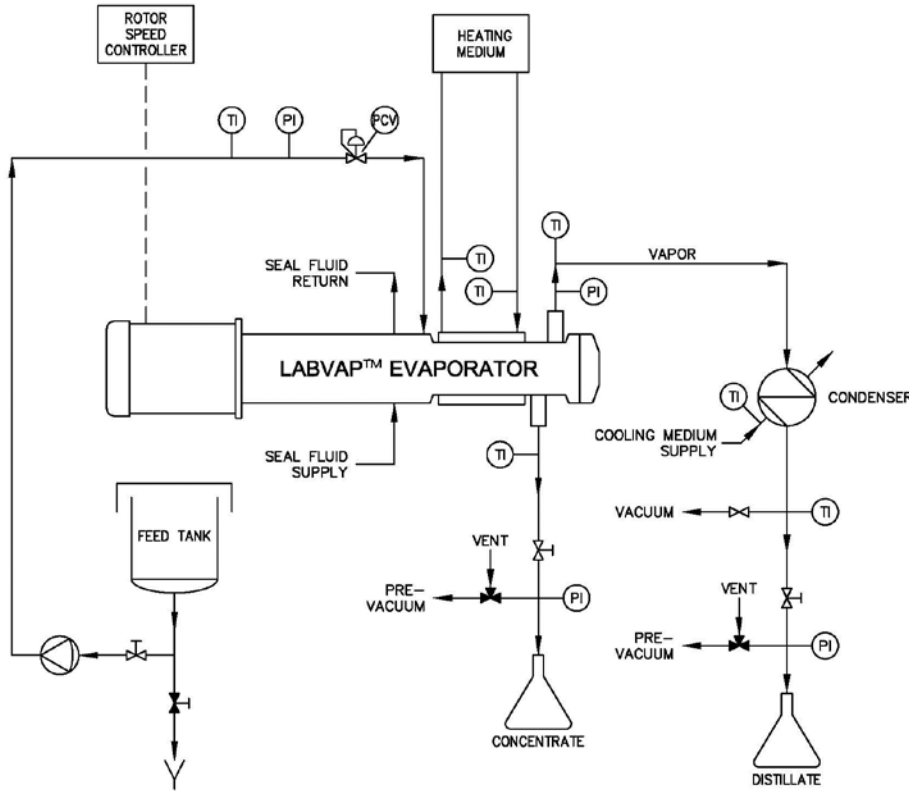

Typical LabVap™ Evaporator Flow Sheet

## How it Works...

Feed material is metered into the thin-film evaporator at a steadily controlled rate by a feed system suitable for the particular feed material.

Steam or hot oil is fed into the jacket for indirect, conductive heat transfer through the thermal wall.

Upon entering the evaporator, the feed is immediately distributed onto the thermal wall by the rotor as a thin liquid film. The product is maintained in a turbulent, thin liquid film by the rotor as it travels down the barrel of the evaporator.

Vapor exits through the top vapor outlet for condensation in a surface condenser. Vacuum is commonly used to reduce the evaporation temperature for temperature sensitive or high-boiling applications.

The concentrate (bottoms) flows by gravity out of the evaporator bottom outlet into a discharge system.

Capacity can be varied by adjusting feed rate, heating temperature, rotor speed, and/or vacuum to achieve the desired product concentration result.

## What can you use this for?

- Sanitary food processing
- Hygienic pharmaceutical (API) concentration
- Concentration and purification of botanical extracts and fermentation broths
- Concentrating dairy products
- Remove solvents from active ingredients (AI)
- Designs incorporating clean-in-place (CIP) requirements
- Lecithin Drying

## FAST FACTS

<b>Heated Surface Area</b>	0.5 ft <sup>2</sup>
<b>Material of Construction</b>	316 SS process wetted parts
<b>Process Area P/T Rating</b>	FV to ATM @ 650°F
<b>Jacket P/T Rating</b>	150 psig @ 365°F (steam) 100 psig @ 650°F (liquid)
<b>Feed Rate</b>	2-40 lb/hr (typical)
<b>Viscosity</b>	8,000 cP max (typical)



LCI Corporation  
4433 Chesapeake Drive  
Charlotte, NC 28216

704-394-8341  
Email [info@lccorp.com](mailto:info@lccorp.com)  
[www.lccorp.com](http://www.lccorp.com)